

**Parts List**  
**For Portable Compressors**

**XAS 186 Dd**



**Parts List  
For Portable Compressors**

**XAS 186 Dd**

Parts Index ..... 4  
Warranty and Liability .....7  
Safety Precautions for Portable Compressors ..... 9  
Ordering Spare Parts ..... 13  
Parts Lists ..... 17

**Printed Matter N°**

2955 1070 00

**01/2007**



---

ATLAS COPCO - PORTABLE AIR DIVISION  
[www.atlascopco.com](http://www.atlascopco.com)

---

**PARTS INDEX**

**PARTS INDEX**

<b>PART</b>	<b>PAGE</b>	<b>PART</b>	<b>PAGE</b>
<b>A</b>			
A.C. EYE .....	82	DAMPER .....	126, 128
ACTUATING UNIT ASSEMBLY .....	40, 73	DECAL .....	57, 66
ADAPTER .....	69, 73, 97	DIN EYE .....	82
AFTERCOOLER .....	104, 105, 106, 107, 108, 109	DISTANCE SLEEVE .....	52
AIR INLET .....	50, 51	DOOR .....	52
AIR OUTLET .....	47	DRIVE .....	55
AIR OUTLET PIPE .....	58, 59	DUCT .....	52
AIRDUCT .....	50	<b>E</b>	
AIRFILTER .....	50	ELBOW .....	44
AIR FILTER ELEMENT .....	50	ELBOW PIPE COUPLING .....	40, 72
ANTI VIBRATION PAD .....	32	ELECTRICAL SYSTEM .....	54
ANTENNA .....	84, 85	ELEMENT MOUNTING .....	31
APPLIANCE INLET .....	98, 99	ENGINE .....	62, 64, 118, 120
ASSEMBLY .....	61, 76, 77	ENGINE AND ACCESSORIES .....	36, 37
AXLE .....	86, 88, 90, 124, 125	ENGINE AND FITTINGS .....	120, 121
<b>B</b>			
BAFFLE .....	61, 76, 77	ENGINE AND OIL SEPARATOR .....	62, 63, 118, 119
BALL BEARING .....	38	ENGINE AND PIPE .....	64, 65
BALL CAGE .....	81	ENGINE COOLANT .....	23
BALL COUPLING .....	82, 83	ENGINE COOLING .....	44, 45
BALL VALVE .....	47, 112, 116, 117	ENGINE OIL .....	18, 19
BALL VALVE ASSEMBLY .....	47	ENGINE SPEED REGULATOR .....	73
BASE PLATE .....	52	EQUALIZER .....	126, 128
BATTERY .....	62, 64, 118, 120	EXHAUST ELBOW .....	36
BATTERY CABLE .....	54	EXHAUST PIPE .....	36, 95
BODYWORK AND MOUNTS .....	52, 53	<b>F</b>	
BRACKET FUELFILTER .....	34	FAN .....	42
BRAKE CABLE .....	88, 90, 126, 128	FAN ADAPTOR .....	42
BRAKE DRUM .....	124	FAN COWL .....	42
BRAKE SEGMENT .....	126, 128	FAN GUARD .....	42
BRAKE SHOES .....	25	FAN GUIDE .....	42
BUMPER BAR .....	99	FILTER ELEMENT .....	34
BUSH .....	40, 82, 83, 126, 128	FILTER HEAD .....	62, 64
BUSHING .....	38, 74, 124, 126, 128	FOOT .....	92
<b>C</b>			
CABLE .....	98, 99, 126, 128	FRAME .....	32, 68
CABLE CLAMP .....	40, 54, 98, 99	FRAME AND MOUNTS .....	32, 33
CABLE CLIP .....	44	FRONT MARKER .....	98, 99
CABLE STRIP .....	54, 126, 128	FRONT PANEL .....	52
CAP .....	69	FUEL GAUGE .....	34
CATCH .....	52	FUEL HOSE .....	34, 44
CHAIN ASSEMBLY .....	92	FUEL SYSTEM .....	34, 35
CIRCLIP .....	38	FUELFILTER .....	34
CIRCUIT BREAKER .....	54	FUEL TANK .....	69
CLAMP .....	36, 50, 54, 98, 99, 118, 120, 124, 126, 127, 128	FUEL TANK ASSEMBLY .....	34, 69
CLAMP ASSEMBLY .....	92	<b>G</b>	
CLASP .....	126, 128	GASSPRING .....	52
CLIP .....	126, 127, 128	GEAR CASING .....	38
COMPRESSOR SPRING .....	73	GEAR CASING AND MOUNTS .....	38
COMPRESSOR OIL .....	20, 21, 22	GEARSET .....	55
CONNECTION .....	104, 106, 108	GROMMET .....	54, 69, 98, 99
CONTAINER .....	21	<b>H</b>	
COOLER .....	42	HANDGRIP .....	52
COOLER AND FAN .....	42, 43	HANDLE .....	81, 126, 127, 128
COSMOS .....	84, 85	HEXAGON PLUG .....	42, 47, 74, 78, 79, 104, 106, 108
COSMOS MODULE .....	84, 85	HINGE .....	52
COUPLING .....	39, 74	HOSE .....	34, 44, 50
COUPLING HUB .....	39	HOSE ASSEMBLY .....	36, 44, 46, 47, 112, 114, 118, 120
COUPLING RING .....	39	HOSE CLAMP .....	34, 36, 44, 50
COVER .....	52, 67, 80, 78, 79, 118, 120	HOLDER (DOCUMENT) .....	52
COVER PLATE .....	126, 128		

**PARTS INDEX**

**PARTS INDEX**

<b>PART</b>	<b>PAGE</b>	<b>PART</b>	<b>PAGE</b>
<b>H</b>			
HOSE INTERCOOLER .....	44	PIPE AFTERCOOLER .....	104, 106, 108
HOURLMETER .....	72	PIPE CLAMP .....	94, 95
HOUSING .....	34, 126, 127, 128	PIPE COUPLING .....	40, 56, 57
HOUSE MARK .....	49	PIPES AND VALVE .....	112
HUB .....	125	PISTON .....	73, 74
<b>I</b>			
INDICATOR .....	50	PISTON ROD .....	74
INFORMATION LABEL .....	49, 66	PLASTIC TUBE .....	36, 40, 69, 74, 104, 106, 108, 112
INSTRUCTION LABEL .....	49	PLATE .....	32, 36, 52, 72, 76, 77, 126
INSTRUMENT PANEL ASSEMBLY .....	48, 72	PLUG .....	32, 48, 69
INSULATION .....	36	PRESSURE GAUGE .....	72, 96
INSULATION HOSE .....	36	PRESSURE VESSEL .....	70, 71, 78, 79
<b>K</b>			
KEY .....	52	PROTECT COVER .....	68
KNOB .....	80	PROTECTION .....	36, 98, 99, 123
<b>L</b>			
LABEL .....	72, 122	PROTECTION CAP .....	54
LABEL NOISE .....	66	PROTECTION PLUG .....	52
LEVEL GAUGE .....	34, 70, 71	PUSH BUTTON .....	34
LEVEL SWITCH .....	44	<b>Q</b>	
LEVER .....	40, 126, 128	QD-FILTER .....	108
LIFTING EYE .....	32	QUICK COUPLING .....	92
LIGHT LH .....	99, 123	<b>R</b>	
LIP SEAL .....	38	RADIATOR .....	42
LOAD VALVE ASSEMBLY .....	72, 80	RADIATOR CAP .....	44
LOADING VALVE .....	30	REDUCTION .....	69
LUBRICATOR .....	111	REFLECTOR .....	98, 99
LUBRICATOR ASSEMBLY .....	111	REGULATING SYSTEM .....	40, 41
<b>M</b>			
MANIFOLD .....	47	REGULATING VALVE .....	28
MARKINGS .....	49, 66	REGULATING VALVE ASSEMBLY .....	70, 71, 81
METAL FILLERNECK .....	93	REHEATER .....	114, 115
MINIMUM PRESSURE VALVE .....	47	RELAY .....	54
MODULE .....	72	RESTRICTOR .....	104, 106, 108
MUDGUARD .....	86, 88, 90	RETAINER .....	38, 67, 70, 71
<b>N</b>			
NATO EYE .....	83	RETAINING RING .....	80
NYLON BAND .....	67	RING .....	40
<b>O</b>			
OIL CAN .....	20, 21, 22	ROAD AXLE BEARINGS .....	29
OIL FILTER .....	60	ROAD LIGHT SYSTEM .....	98, 99
OIL NOZZLE .....	38	ROD .....	127, 128
OIL SEPARATOR .....	27, 57, 62, 70, 71, 118	<b>S</b>	
OIL SYSTEM .....	46	SAFETY AND CONTROL .....	48
<b>P</b>			
PANEL .....	52, 72, 123	SAFETY CARTRIDGE .....	101
PANEL ASSEMBLY .....	98, 123	SAFETY CHAIN .....	92
PARALLEL KEY .....	38, 39	SAFETY VALVE .....	56, 57
PARALLEL PIN .....	38	SERIAL CONNECT SET .....	106, 108
PAROIL .....	18, 19, 20, 21, 22	SERVICE KIT .....	24, 25, 26, 27, 28, 29, 30, 31
PARTS FROM SERVICE PAK .....	129	SERVICE PAK .....	17
PD-FILTER .....	106, 108	SERVICE STAGE .....	38
PIPE .....	44, 47, 50, 56, 57, 58, 59, 62, 64, 104, 106, 110, 112, 113	SHOCK ABSORBER .....	126, 128
.....	114, 116, 117	SHACKLE .....	124
		SILENCER .....	36, 104, 106, 108
		SKID .....	102, 103
		SPARK ARRESTOR .....	94
		SPEED REGULATOR .....	24
		SPHERICAL PLAIN BEARING .....	73
		SPRING .....	73, 80, 81
		SPRING COVER .....	81
		SPRING CLIP .....	52
		SPRING GUIDE .....	81
		SPRING SEAT .....	81
		STEEL DRUM .....	20, 21, 22
		STIRRUP .....	52
		STRAIGHT PIPE-COUPLING .....	96

---

**PARTS INDEX**

---

**PARTS INDEX**

<b>PART</b>	<b>PAGE</b>	<b>PART</b>	<b>PAGE</b>
<b>S</b>			
STRAINER.....	69		
STRAP.....	34		
SUPPORT.....	34, 32, 50, 54, 82, 92, 100		
SUPPORT BATT.....	118, 120		
SWIVEL WHEEL.....	92		
<b>T</b>			
TEE.....	96		
TEE PIPE COUPLING.....	44		
TEMPERATURE SWITCH.....	48		
THERMOST.....	118, 120		
TOOL BOX.....	67		
TOPTANK.....	44		
TOWBAR.....	86, 88, 90, 126, 127, 128		
TOWBAR ACCESSORIES.....	92		
TOWBAR AND AXLE.....	86, 87, 88, 89, 90, 91		
TOWING EYE.....	82, 83		
TUBE.....	32, 70, 71		
TYRE.....	86, 88, 90		
TYRE ASSEMBLY.....	86, 88, 90		
<b>U</b>			
UNLOADING VALVE.....	26, 40		
UNLOADING VALVE ASSEMBLY.....	74, 75		
<b>V</b>			
VALVE.....	74, 80, 118, 120		
VALVE HOUSING.....	47, 118, 120		
VALVE ROD.....	80		
VALVES ON VESSEL.....	56, 57		
VENTIL.....	86, 88, 90		
VESSEL.....	78, 79		
<b>W</b>			
WARNING LABEL.....	49, 57, 86, 88, 90		
WARRANTY LABEL.....	49, 66		
WHEEL.....	86, 88, 90		
WHEELCHOCKS.....	122		
WINDOW.....	72		
WIRING COSMOS.....	84, 85		
WIRE HARNESS.....	34, 54, 98, 99		
WSD-FILTER.....	104, 106, 108		

## Warranty and Liability Limitation

Use only authorized parts.  
Any damage or malfunction caused by the use of unauthorized parts is not covered by Warranty or Product Liability.  
The manufacturer does not accept any liability for any damage arising from modifications, additions or conversions made without the manufacturer's approval in writing.

Copyright 2004, Atlas Copco Airpower n.v., Antwerp, Belgium.  
Any unauthorized use or copying of the contents or any part thereof is prohibited.  
This applies in particular to trademarks, model denominations, part numbers and drawings.

## Garantie- en aansprakelijkheidsbepalingen

Gebruik alleen originele onderdelen.  
Beschadiging of defecten die het gevolg zijn van het gebruik van niet originele onderdelen vallen niet onder garantie of productaansprakelijkheid.  
De producent is niet aansprakelijk voor enige schade veroorzaakt door modificatie, toevoeging of ombouw, gemaakt zonder de schriftelijke toestemming van de fabrikant.

Copyright 2004, Atlas Copco Airpower n.v., Antwerpen, België.  
Het is niet toegestaan om zonder toestemming de inhoud geheel of gedeeltelijk te kopiëren of anderszins te gebruiken.  
Dit betreft vooral trademarks, modelbenamingen, onderdeelnummers en tekeningen.

## Limitation de garantie et de responsabilité

Utiliser uniquement les pièces homologuées.  
Tout dommage ou mauvais fonctionnement dû à l'utilisation de pièces non homologuées n'est pas couvert par la garantie ou la responsabilité des produits défectueux.  
Le fabricant décline toute responsabilité en cas de dommage faisant suite à des modifications, des ajouts ou des conversions effectués sans l'accord écrit du fabricant.

Copyright 2004, Atlas Copco Airpower n.v., Antwerp, Belgique.  
Toute utilisation ou copie du contenu, ou d'une partie de celui-ci, non autorisée est interdite.  
Cette interdiction s'applique en particulier aux marques de commerce, aux dénominations des modèles, aux numéros des pièces et aux schémas.

## Garantie- und Haftungseinschränkungen

Nur zugelassene Teile verwenden.  
Jede Beschädigung oder Fehlfunktion, die durch die Verwendung von nicht zugelassenen Teilen verursacht wurde, ist nicht durch die Garantie oder Produkthaftung abgedeckt.  
Der Hersteller übernimmt keine Haftung für Schäden, die durch Modifizierungen, Ergänzungen oder Funktionsänderungen entstehen, die ohne schriftliche Zustimmung des Herstellers erfolgt sind.

Urheberrecht 2004, Atlas Copco Airpower n.v., Antwerpen, Belgien.  
Jede nicht genehmigte Verwendung oder Kopie des Inhaltes oder von Teilen ist untersagt.  
Das bezieht sich im Einzelnen auf Warenzeichen, Modellbezeichnungen, Teilenummern und Zeichnungen.

## Limitación de garantía y responsabilidad

Use sólo piezas autorizadas.  
La garantía o responsabilidad del producto no cubre ningún daño o funcionamiento defectuoso provocado por el uso de piezas no autorizadas.  
El fabricante no acepta ninguna responsabilidad por los daños provocados por modificaciones, adiciones o conversiones realizadas sin la aprobación por escrito del fabricante.

Derechos de reproducción 2004, Atlas Copco Airpower n.v., Amberes, Bélgica.  
Está prohibida toda utilización o reproducción total o parcial no autorizada de estos contenidos, en especial de las marcas registradas, denominaciones de modelos, números de piezas y planos.

## Begränsningar av garanti och ansvarsskyldighet

Använd endast godkända delar.  
Den skada eller funktionsoduglighet som förorsakats av att ej godkända delar har använts, täcks inte av garantin eller produktansvaret.  
Tillverkaren accepterar ingen ansvarsskyldighet för skador som uppstår efter att ändringar, tillägg eller ombyggnader gjorts utan skriftligt tillstånd från tillverkaren.

Copyright 2004, Atlas Copco Airpower n.v., Antwerpen, Belgien.  
Ej auktoriserad användning eller kopiering av innehållet, eller delar av det, är förbjuden.  
Detta gäller speciellt varumärken, modellbeteckningar, reservdelsnummer och ritningar.

## Limitazione di Garanzia e di Responsabilità

Usare solo componenti autorizzati.  
Qualsiasi danno o malfunzione causati dall'uso di componenti non autorizzati non è coperto dalla Garanzia o dalla Responsabilità sul Prodotto.  
Il fabbricante non accetta alcuna responsabilità per danni derivanti da modifiche, aggiunte o trasformazioni effettuate senza l'approvazione scritta del fabbricante.

Copyright 2004, Atlas Copco Airpower n.v., Anversa, Belgio.  
Sono vietati ogni uso o copia non autorizzati del contenuto o di qualsiasi parte dello stesso.  
Ciò si applica in particolare ai marchi, alle denominazioni dei modelli, ai numeri dei componenti ed ai disegni.

## Garanti- og ansvarsbegrænsning

Brug kun tilladte reservedele.  
Enhver skade eller fejlfunktion, forårsaget af brug af ikke tilladte reservedele, omfattes ikke af garantien eller produktansvaret.  
Fabrikanten kan ikke drages til ansvar for nogen skade som følge af ændringer, udvidelser eller ombygninger, der er blevet udført uden fabrikantens skriftlige samtykke.

Copyright 2004, Atlas Copco Airpower n.v., Antwerpen, Belgien.  
Enhver uautoriseret brug eller kopiering af indholdet eller dele deraf er forbudt.  
Dette gælder især varemærker, modelbenævnelser, delnumre og tegninger.

## Εγγύηση και Περιορισμός Ευθύνης

Χρησιμοποιήστε μόνο εγκεκριμένα εξαρτήματα.  
Οποιαδήποτε ζημιά ή δυσλειτουργία προκληθεί από τη χρήση μη εγκεκριμένων εξαρτημάτων δεν καλύπτεται από την εγγύηση και την ευθύνη για το προϊόν.  
Ο κατασκευαστής δεν αποδέχεται καμία ευθύνη για ζημιές που προκύπτουν από τροποποιήσεις, προσθήκες ή μετατροπές που έγιναν χωρίς τη γραπτή έγκριση του κατασκευαστή.

Copyright 2004, Atlas Copco Airpower n.v., Αμβέρσα, Βέλγιο.  
Απαγορεύεται οποιαδήποτε χρήση ή αντιγραφή του περιεχόμενου ή οποιουδήποτε τμήματος του παρόντος χωρίς εξουσιοδότηση.  
Αυτό ισχύει συγκεκριμένα για εμπορικά σήματα, ονομασίες μοντέλων, κωδικούς εξαρτημάτων και σχέδια.

## Garanti og ansvarsbegrensning

Bruk kun autoriserte deler.  
Enhver skade eller funksjonsfeil som skyldes bruk av uautoriserte deler dekkes ikke av garanti eller produktansvar.  
Fabrikanten aksepterer intet ansvar for noen skade som oppstår på grunn av modifikasjoner, tilføyelser eller forandringer som er gjort uten fabrikantens skriftlige tillatelse.

Copyright 2004, Atlas Copco Airpower n.v., Antwerpen, Belgia.  
All uautorisert bruk eller kopiering av innholdet eller en del av det er forbudt.  
Dette gjelder særlig varemerker, modellbenevnelser, delenumre og tegninger.

## Takuun ja vastuuvollisuuden rajoitus

Käytä vain valmistajan hyväksymiä varaosia.  
Takuu ja tuotevastuu eivät kata vahinkoja tai toimintahäiriöitä, joiden syynä on muuten kuin hyväksytyjen varaosien käyttö.  
Valmistaja ei vastaa vahingoista, jotka aiheutuvat ilman valmistajan kirjallista lupaa tehdystä muutoksista tai lisäyksistä.

Copyright 2004, Atlas Copco Airpower n.v., Antwerpen, Belgia.  
Sisällön osittainenkin käyttö tai kopiointi ilman lupaa on kielletty.  
Tämä koskee erityisesti tavaramerkkejä, mallien nimiä, osanumeroita ja piirustuksia.

## Garantijas un atbildības ierobežojumi

Izmantot tikai ieteiktās rezerves daļas.  
Īj garantija nesedz bojājumus vai disfunkciju, kuri ir radušies neatļautu rezerves daļu izmantošanas rezultātā.  
Ražotājs nepieņem pretenzijas par bojājumiem, kas izriet no modifikācijām, papildinājumiem vai pārveidojumiem bez ražotāja rakstiskas piekrišanas.

Autortiesības 2004, Atlas Copco Airpower n.v., Antverpene, Beļģija.  
Jebkura neatļautā īj satura izmantošana vai kopšana ir aizliegta. Tas konkrēti attiecas uz tirdzniecības zīmēm, modeļu denominācijām, daļu numuriem un rāscijumiem.

## Limites de Garantia e Responsabilidade

Utilize apenas peças autorizadas.

Avárias ou defeitos de funcionamento que sejam causados pelo uso de sobresselentes ou componentes não autorizados não serão cobertos pela Garantia ou pela Responsabilidade de Produto.

O fabricante não aceita qualquer responsabilidade por quaisquer danos resultantes de modificações, adições ou conversões efectuadas sem a aprovação escrita do fabricante.

Copyright 2004, Atlas Copco Airpower n.v., Antuérpia, Bélgica.

Qualquer uso não autorizado ou cópia do conteúdo ou de qualquer parte dele é proibida.

Isto aplica-se em particular a marcas registadas, denominações de modelos, números de peças e desenhos.

## 有限担保和责任

只允许使用经认可的零件。

因使用未经认可的零件而导致的任何损坏或故障不在本担保或产品责任所保障的范围之内。

未经制造商书面许可，制造商概不负责因擅自对设备进行改动、添加附件或改型而导致的设备损坏。

版权 2004，比利时安特卫普 Atlas Copco Airpower n.v.。

未经许可，禁止使用或复制本手册中所含的全部或任何一部分内容。

本公告特别适用于本手册所含的商标、型号名称、零件代号和图纸。

## A garancia és felelősség korlátozása

Csak jóváhagyott alkatrészeket használjon!

A nem jóváhagyott alkatrészek használatából adódó sérülésekre és üzemzavarra nem terjed ki a garancia és a termékfelelősség. A gyártó semminemű felelősséget nem vállal a gyártó írásos jóváhagyása nélkül végzett bármilyen módosításokból, kiegészítésekéből vagy átalakításokból adódó sérülésekért.

Copyright 2004, Atlas Copco Airpower n.v., Antwerp, Belgium.

A kézikönyv tartalma vagy annak egy részének engedély nélküli felhasználása vagy másolása tilos.

Ez vonatkozik különösen a védjegyekre, a típusjelölésekre, cikkszámokra és rajzokra.

## Zárka a obmedzenia zodpovednosti výrobcu

Používajte len schválené súčiastky.

Akákolvek škoda alebo porucha spôsobená použitím neschválených súčiastok nie je zahrnutá v záruke ani zodpovednosti výrobcu za škodu. Výrobca nepripúšťa žiadnu zodpovednosť za akékoľvek škody vzniknuté úpravou, pridaním alebo prerobením, ktoré boli vykonané bez predchádzajúceho písomného súhlasu výrobcu.

Autorské práva 2004, Atlas Copco Airpower n.v., Antverpy, Belgicko.

Akékoľvek neoprávnené použitie alebo kopírovanie obsahu, alebo jeho časti je zakázané. Toto sa vzťahuje najmä na obchodné značky, modelové označenia, čísla súčiastok a nákresy.

## Garantii ja piiratud vastutus

Kasutage ainult valmistaja poolt aktsepteeritud varuosi.

Mis tahes vigastus või rike, mille on põhjustanud valmistaja poolt aktsepteerimata varuosa kasutamine, ei kuulu toote garantii või tootja vastutuse alla. Valmistaja ei aktsepteeri ühtegi riket, mis on tekkinud toote modifitseerimisest, lisandustest või ümberehitamisest, mida valmistaja ei ole kirjalikult heaks kiitnud.

Copyright 2004, Atlas Copco Airpower n.v., Antwerp, Belgium.

Käesoleva juhendi mistahes loata kasutamine või kopeerimine on keelatud.

See kehtib nii kaubamärkide, mudeli nimetuste, varuosade numbritel kui ka joonistel koht.

## Ограничение гарантии и ответственности

Используйте компоненты только авторизованных поставщиков.

Не распространяется гарантия и ответственность за продукцию при любых повреждениях или неисправностях в результате использования неавторизованных компонентов.

Производитель не несет никакой ответственности за любые повреждения, возникшие в результате модификации, дополнения или изменения, выполненные без письменного утверждения производителя.

Copyright 2004, Atlas Copco Airpower n.v., Антверпен, Бельгия.

Запрещается любое несанкционированное использование или копирование содержания этих материалов или их части.

В особенности это относится к торговым маркам, обозначениям моделей, номерам деталей и чертежам.

## Gwarancja i ograniczenie odpowiedzialności

Stosować jedynie oryginalne części zamienne.

Jakiegokolwiek uszkodzenia lub niesprawności spowodowane stosowaniem niezaaprobowanych części zamiennych nie są objęte gwarancją lub odpowiedzialnością za produkt.

Producent nie będzie ponosił żadnej odpowiedzialności za jakiegokolwiek szkody spowodowane modyfikacjami, dodatkami lub zmianami wykonanymi bez pisemnej zgody producenta.

Copyright 2004, Atlas Copco Airpower n.v., Antwerpia, Belgia.

Wszelkie stosowanie lub kopiowanie zawartości lub jakiegokolwiek części publikacji bez zezwolenia jest zabronione.

Dotyczy to szczególnie znaków handlowych, oznaczeń modeli, numerów części oraz rysunków.

## Omezení záruky a odpovědnosti

Používejte pouze takové součásti, které jsou schválené výrobcem zařízení. Jakékoliv poškození nebo závady způsobené použitím součástí, které nebyly schválené výrobcem zařízení, nejsou kryty zárukou, nebo odpovědností za výrobek.

Výrobce nepřijímá žádnou odpovědnost za jakékoliv škody, způsobené modifikacemi, doplňky nebo přestavbami zařízení provedenými bez předchozího písemného svolení.

Copyright 2004, Atlas Copco Airpower n.v., Antverpy, Belgie.

Jakékoliv neoprávněné použití nebo kopírování obsahu tohoto dokumentu nebo kterékoliv jeho částí je zakázáno.

Toto platí obzvláště pro obchodní známky, označení modelů, čísla součástí a výkresovou dokumentaci.

## Garancijski pogoji in omejitve

Uporabljajte samo odobrene dele.

Garancija proizvajalca ni veljavna pri poškodbah ali motnjah v delovanju, ki so posledica uporabe neodobrenih delov.

Proizvajalec ne prevzema nikakršne odgovornosti za poškodbe, ki so nastale zaradi sprememb, dodatkov ali prilagoditev na izdelku, ki so bile izvedene brez pisne odobritve proizvajalca.

Copyright 2004, Atlas Copco Airpower n.v., Antwerp, Belgium.

Brez pisnega dovoljenja ni dovoljeno uporabljati ali razmnoževati nobenega dela dokumenta.

To velja še posebej za blagovne znamke, označbe modelov, številke izdelkov in risbe.

## Garantijos ir atsakomybės galiojimas

Naudokite tik originalias dalis.

Garantija nebus taikoma tuo atveju, jeigu pala ar sutrikimas atsiranda naudojant neoriginalias dalis.

Gamintojas neprisiima jokios atsakomybės dėl žalos, susijusios su modifikacija, papildymu ar perdirbimu, atliktu be raštiško gamintojo sutikimo.

Autorstės teisė 2004, "Atlas Copco Airpower n.v.", Antverpenas, Belgija.

Neteisėtas viso teksto ar kurios nors jo dalies panaudojimas ar kopijavimas yra draudžiamas.

Visø pirma õi sàlyga taikoma prekiniams penklams, modeliø pavadinimams, daliø numeriams ir brøþiniams.



---

# 1. SAFETY PRECAUTIONS FOR PORTABLE COMPRESSORS

To be read attentively and acted accordingly before towing, lifting, operating, performing maintenance or repairing the compressor

## 1.1 INTRODUCTION

The policy of Atlas Copco is to provide the users of their equipment with safe, reliable and efficient products. Factors taken into account are among others:

- the intended and predictable future use of the products, and the environments in which they are expected to operate,
- applicable rules, codes and regulations,
- the expected useful product life, assuming proper service and maintenance,
- providing the manual with up-to-date information.

Before handling any product, take time to read the relevant instruction manual. Besides giving detailed operating instructions, it also gives specific information about safety, preventive maintenance, etc.

Keep the manual always at the unit location, easy accessible to the operating personnel.

See also the safety precautions of the engine and possible other equipment, which are separately sent along or are mentioned on the equipment or parts of the unit.

These safety precautions are general and some statements will therefore not always apply to a particular unit.

Only people that have the right skills should be allowed to operate, adjust, perform maintenance or repair on Atlas Copco equipment. It is the responsibility of management to appoint operators with the appropriate training and skill for each category of job.

### **Skill level 1: Operator**

An operator is trained in all aspects of operating the unit with the push-buttons, and is trained to know the safety aspects.

### **Skill level 2: Mechanical technician**

A mechanical technician is trained to operate the unit the same as the operator. In addition, the mechanical technician is also trained to perform maintenance and repair, as described in the instruction manual, and is allowed to change settings of the control and safety system. A mechanical technician does not work on live electrical components.

### **Skill level 3: Electrical technician**

An electrical technician is trained and has the same qualifications as both the operator and the mechanical technician. In addition, the electrical technician may carry out electrical repairs within the various enclosures of the unit. This includes work on live electrical components.

### **Skill level 4: Specialist from the manufacturer**

This is a skilled specialist sent by the manufacturer or its agent to perform complex repairs or modifications to the equipment.

In general it is recommended that not more than two people operate the unit, more operators could lead to unsafe operating conditions. Take necessary steps to keep unauthorized persons away from the unit and eliminate all possible sources of danger at the unit.

When handling, operating, overhauling and/or performing maintenance or repair on Atlas Copco equipment, the mechanics are expected to use safe engineering practices and to observe all relevant local safety requirements and ordinances. The following list is a reminder of special safety directives and precautions mainly applicable to Atlas Copco equipment.

These safety precautions apply to machinery processing or consuming air. Processing of any other gas requires additional safety precautions typical to the application and are not included herein.

Neglecting the safety precautions may endanger people as well as environment and machinery:

- endanger people due to electrical, mechanical or chemical influences,
- endanger the environment due to leakage of oil, solvents or other substances,
- endanger the machinery due to function failures.

All responsibility for any damage or injury resulting from neglecting these precautions or by non-observance of ordinary caution and due care required in handling, operating, maintenance or repair, also if not expressly mentioned in this instruction manual, is disclaimed by Atlas Copco.

The manufacturer does not accept any liability for any damage arising from the use of non-original parts and for modifications, additions or conversions made without the manufacturer's approval in writing.

If any statement in this manual does not comply with local legislation, the stricter of the two shall be applied.

Statements in these safety precautions should not be interpreted as suggestions, recommendations or inducements that it should be used in violation of any applicable laws or regulations.

## 1.2 GENERAL SAFETY PRECAUTIONS

- 1 The owner is responsible for maintaining the unit in a safe operating condition. Unit parts and accessories must be replaced if missing or unsuitable for safe operation.
- 2 The supervisor, or the responsible person, shall at all times make sure that all instructions regarding machinery and equipment operation and maintenance are strictly followed and that the machines with all accessories and safety devices, as well as the consuming devices, are in good repair, free of abnormal wear or abuse, and are not tampered with.
- 3 Whenever there is an indication or any suspicion that an internal part of a machine is overheated, the machine shall be stopped but no inspection covers shall be opened before sufficient cooling time has elapsed; this to avoid the risk of spontaneous ignition of oil vapour when air is admitted.
- 4 Normal ratings (pressures, temperatures, speeds, etc.) shall be durably marked.
- 5 Operate the unit only for the intended purpose and within its rated limits (pressure, temperature, speeds, etc.).
- 6 The machinery and equipment shall be kept clean, i.e. as free as possible from oil, dust or other deposits.
- 7 To prevent an increase in working temperature, inspect and clean heat transfer surfaces (cooler fins, intercoolers, water jackets, etc.) regularly. See the maintenance schedule.
- 8 All regulating and safety devices shall be maintained with due care to ensure that they function properly. They may not be put out of action.
- 9 Care shall be taken to avoid damage to safety valves and other pressure-relief devices, especially to avoid plugging by paint, oil coke or dirt accumulation, which could interfere with the functioning of the device.
- 10 Pressure and temperature gauges shall be checked regularly with regard to their accuracy. They shall be replaced whenever outside acceptable tolerances.
- 11 Safety devices shall be tested as described in the maintenance schedule of the instruction manual to determine that they are in good operating condition.
- 12 Mind the markings and information labels on the unit.
- 13 In the event the safety labels are damaged or destroyed, they must be replaced to ensure operator safety.
- 14 Keep the work area neat. Lack of order will increase the risk of accidents.
- 15 When working on the unit, wear safety clothing. Depending on the kind of activities these are: safety glasses, ear protection, safety helmet (including visor), safety gloves, protective clothing, safety shoes. Do not wear the hair long and loose (protect long hair with a hairnet), or wear loose clothing or jewelry.
- 16 Take precautions against fire. Handle fuel, oil and anti-freeze with care because they are inflammable substances. Do not smoke or approach with naked flame when handling such substances. Keep a fire-extinguisher in the vicinity.

---

### 1.3 SAFETY DURING TRANSPORT AND INSTALLATION

To lift a unit, all loose or pivoting parts, e.g. doors and towbar, shall first be securely fastened.

Do not attach cables, chains or ropes directly to the lifting eye; apply a crane hook or lifting shackle meeting local safety regulations. Never allow sharp bends in lifting cables, chains or ropes.

Helicopter lifting is not allowed.

It is strictly forbidden to dwell or stay in the risk zone under a lifted load. Never lift the unit over people or residential areas. Lifting acceleration and retardation shall be kept within safe limits.

- 1 Before towing the unit:
  - ascertain that the pressure vessel(s) is (are) depressurized,
  - check the towbar, the brake system and the towing eye. Also check the coupling of the towing vehicle,
  - check the towing and brake capability of the towing vehicle,
  - check that the towbar, jockey wheel or stand leg is safely locked in the raised position,
  - ascertain that the towing eye can swivel freely on the hook,
  - check that the wheels are secure and that the tyres are in good condition and inflated correctly,
  - connect the signalisation cable, check all lights and connect the pneumatic brake couplers,
  - attach the safety break-away cable or safety chain to the towing vehicle,
  - remove wheel chocks, if applied, and disengage the parking brake.
- 2 To tow a unit use a towing vehicle of ample capacity. Refer to the documentation of the towing vehicle.
- 3 If the unit is to be backed up by the towing vehicle, disengage the overrun brake mechanism (if it is not an automatic mechanism).
- 4 Never exceed the maximum towing speed of the unit (mind the local regulations).
- 5 Place the unit on level ground and apply the parking brake before disconnecting the unit from the towing vehicle. Unclip the safety break-away cable or safety chain. If the unit has no parking brake or jockey wheel, immobilize the unit by placing chocks in front of and/or behind the wheels. When the towbar can be positioned vertically, the locking device must be applied and kept in good order.
- 6 To lift heavy parts, a hoist of ample capacity, tested and approved according to local safety regulations, shall be used.
- 7 Lifting hooks, eyes, shackles, etc., shall never be bent and shall only have stress in line with their design load axis. The capacity of a lifting device diminishes when the lifting force is applied at an angle to its load axis.
- 8 For maximum safety and efficiency of the lifting apparatus all lifting members shall be applied as near to perpendicular as possible. If required, a lifting beam shall be applied between hoist and load.
- 9 Never leave a load hanging on a hoist.
- 10 A hoist has to be installed in such a way that the object will be lifted perpendicular. If that is not possible, the necessary precautions must be taken to prevent load-swinging, e.g. by using two hoists, each at approximately the same angle not exceeding 30° from the vertical.
- 11 Locate the unit away from walls. Take all precautions to ensure that hot air exhausted from the engine and driven machine cooling systems cannot be recirculated. If such hot air is taken in by the engine or driven machine cooling fan, this may cause overheating of the unit; if taken in for combustion, the engine power will be reduced.

### 1.4 SAFETY DURING USE AND OPERATION

- 1 When the unit has to operate in a fire-hazardous environment, each engine exhaust has to be provided with a spark arrester to trap incendiary sparks.
- 2 The exhaust contains carbon monoxide which is a lethal gas. When the unit is used in a confined space, conduct the engine exhaust to the outside atmosphere by a pipe of sufficient diameter; do this in such a way that no extra back pressure is created for the engine. If necessary, install an extractor. Observe any existing local regulations. Make sure that the unit has sufficient air intake for operation. If necessary, install extra air intake ducts.
- 3 When operating in a dust-laden atmosphere, place the unit so that dust is not carried towards it by the wind. Operation in clean surroundings considerably extends the intervals for cleaning the air intake filters and the cores of the coolers.
- 4 Close the compressor air outlet valve before connecting or disconnecting a hose. Ascertain that a hose is fully depressurized before disconnecting it. Before blowing compressed air through a hose or air line, ensure that the open end is held securely, so that it cannot whip and cause injury.
- 5 The air line end connected to the outlet valve must be safeguarded with a safety cable, attached next to the valve.
- 6 No external force may be exerted on the air outlet valves, e.g. by pulling on hoses or by installing auxiliary equipment directly to a valve, e.g. a water separator, a lubricator, etc. Do not step on the air outlet valves.
- 7 Never move a unit when external lines or hoses are connected to the outlet valves, to avoid damage to valves, manifold and hoses.
- 8 Do not use compressed air from any type of compressor, without taking extra measures, for breathing purposes as this may result in injury or death. For breathing air quality, the compressed air must be adequately purified according to local legislation and standards. Breathing air must always be supplied at stable, suitable pressure.
- 9 Distribution pipework and air hoses must be of correct diameter and suitable for the working pressure. Never use frayed, damaged or deteriorated hoses. Replace hoses and flexibles before the lifetime expires. Use only the correct type and size of hose end fittings and connections.
- 10 If the compressor is to be used for sand-blasting or will be connected to a common compressed-air system, fit an appropriate non-return valve (check valve) between compressor outlet and the connected sand-blasting or compressed-air system. Observe the right mounting position/direction.
- 11 Before removing the oil filler plug, ensure that the pressure is released by opening an air outlet valve.
- 12 Never remove a filler cap of the cooling water system of a hot engine. Wait until the engine has sufficiently cooled down.
- 13 Never refill fuel while the unit is running, unless otherwise stated in the Atlas Copco Instruction Book (AIB). Keep fuel away from hot parts such as air outlet pipes or the engine exhaust. Do not smoke when fuelling. When fuelling from an automatic pump, an earthing cable should be connected to the unit to discharge static electricity. Never spill nor leave oil, fuel, coolant or cleansing agent in or around the unit.

- 14 All doors shall be shut during operation so as not to disturb the cooling air flow inside the bodywork and/or render the silencing less effective. A door should be kept open for a short period only e.g. for inspection or adjustment.
- 15 Periodically carry out maintenance works according to the maintenance schedule.
- 16 Stationary housing guards are provided on all rotating or reciprocating parts not otherwise protected and which may be hazardous to personnel. Machinery shall never be put into operation, when such guards have been removed, before the guards are securely reinstalled.
- 17 Noise, even at reasonable levels, can cause irritation and disturbance which, over a long period of time, may cause severe injuries to the nervous system of human beings.  
When the sound pressure level, at any point where personnel normally has to attend, is:  
below 70 dB(A): no action needs to be taken,  
above 70 dB(A): noise-protective devices should be provided for people continuously being present in the room,  
below 85 dB(A): no action needs to be taken for occasional visitors staying a limited time only,  
above 85 dB(A): room to be classified as a noise-hazardous area and an obvious warning shall be placed permanently at each entrance to alert people entering the room, for even relatively short times, about the need to wear ear protectors,  
above 95 dB(A): the warning(s) at the entrance(s) shall be completed with the recommendation that also occasional visitors shall wear ear protectors,  
above 105 dB(A): special ear protectors that are adequate for this noise level and the spectral composition of the noise shall be provided and a special warning to that effect shall be placed at each entrance.
- 18 Insulation or safety guards of parts the temperature of which can be in excess of 80 °C (175 °F) and which may be accidentally touched by personnel shall not be removed before the parts have cooled to room temperature.
- 19 Never operate the unit in surroundings where there is a possibility of taking in flammable or toxic fumes.
- 20 If the working process produces fumes, dust or vibration hazards, etc., take the necessary steps to eliminate the risk of personnel injury.
- 21 When using compressed air or inert gas to clean down equipment, do so with caution and use the appropriate protection, at least safety glasses, for the operator as well as for any bystander. Do not apply compressed air or inert gas to your skin or direct an air or gas stream at people. Never use it to clean dirt from your clothes.
- 22 When washing parts in or with a cleaning solvent, provide the required ventilation and use appropriate protection such as a breathing filter, safety glasses, rubber apron and gloves, etc.
- 23 Safety shoes should be compulsory in any workshop and if there is a risk, however small, of falling objects, wearing of a safety helmet should be included.
- 24 If there is a risk of inhaling hazardous gases, fumes or dust, the respiratory organs must be protected and depending on the nature of the hazard, so must the eyes and skin.
- 25 Remember that where there is visible dust, the finer, invisible particles will almost certainly be present too; but the fact that no dust can be seen is not a reliable indication that dangerous, invisible dust is not present in the air.
- 26 Never operate the unit at pressures or speeds below or in excess of its limits as indicated in the technical specifications.

## 1.5 SAFETY DURING MAINTENANCE AND REPAIR

Maintenance, overhaul and repair work shall only be carried out by adequately trained personnel; if required, under supervision of someone qualified for the job.

- 1 Use only the correct tools for maintenance and repair work, and only tools which are in good condition.
- 2 Parts shall only be replaced by genuine Atlas Copco replacement parts.
- 3 All maintenance work, other than routine attention, shall only be undertaken when the unit is stopped. Steps shall be taken to prevent inadvertent starting. In addition, a warning sign bearing a legend such as "work in progress; do not start" shall be attached to the starting equipment.  
On engine-driven units the battery shall be disconnected and removed or the terminals covered by insulating caps.  
On electrically driven units the main switch shall be locked in open position and the fuses shall be taken out. A warning sign bearing a legend such as "work in progress; do not supply voltage" shall be attached to the fuse box or main switch.
- 4 Before dismantling any pressurized component, the compressor or equipment shall be effectively isolated from all sources of pressure and the entire system shall be relieved of pressure. Do not rely on non-return valves (check valves) to isolate pressure systems. In addition, a warning sign bearing a legend such as "work in progress; do not open" shall be attached to each of the outlet valves.
- 5 Prior to stripping an engine or other machine or undertaking major overhaul on it, prevent all movable parts from rolling over or moving.
- 6 Make sure that no tools, loose parts or rags are left in or on the machine. Never leave rags or loose clothing near the engine air intake.
- 7 Never use flammable solvents for cleaning (fire-risk).
- 8 Take safety precautions against toxic vapours of cleaning liquids.
- 9 Never use machine parts as a climbing aid.
- 10 Observe scrupulous cleanliness during maintenance and repair. Keep away dirt, cover the parts and exposed openings with a clean cloth, paper or tape.
- 11 Never weld on or perform any operation involving heat near the fuel or oil systems. Fuel and oil tanks must be completely purged, e.g. by steam-cleaning, before carrying out such operations. Never weld on, or in any way modify, pressure vessels. Disconnect the alternator cables during arc welding on the unit.
- 12 Support the towbar and the axle(s) securely if working underneath the unit or when removing a wheel. Do not rely on jacks.
- 13 Do not remove any of, or tamper with, the sound-damping material. Keep the material free of dirt and liquids such as fuel, oil and cleansing agents. If any sound-damping material is damaged, replace it to prevent the sound pressure level from increasing.
- 14 Use only lubricating oils and greases recommended or approved by Atlas Copco or the machine manufacturer. Ascertain that the selected lubricants comply with all applicable safety regulations, especially with regard to explosion or fire-risk and the possibility of decomposition or generation of hazardous gases. Never mix synthetic with mineral oil.
- 15 Protect the engine, alternator, air intake filter, electrical and regulating components, etc., to prevent moisture ingress, e.g. when steam-cleaning.
- 16 When performing any operation involving heat, flames or sparks on a machine, the surrounding components shall first be screened with non-flammable material.
- 17 Never use a light source with open flame for inspecting the interior of a machine.

- 18 When repair has been completed, the machine shall be barred over at least one revolution for reciprocating machines, several revolutions for rotary ones to ensure that there is no mechanical interference within the machine or driver. Check the direction of rotation of electric motors when starting up the machine initially and after any alteration to the electrical connection(s) or switch gear, to check that the oil pump and the fan function properly.
- 19 Maintenance and repair work should be recorded in an operator's logbook for all machinery. Frequency and nature of repairs can reveal unsafe conditions.
- 20 When hot parts have to be handled, e.g. shrink fitting, special heat-resistant gloves shall be used and, if required, other body protection shall be applied.
- 21 When using cartridge type breathing filter equipment, ascertain that the correct type of cartridge is used and that its useful service life is not surpassed.
- 22 Make sure that oil, solvents and other substances likely to pollute the environment are properly disposed of.
- 23 Before clearing the unit for use after maintenance or overhaul, check that operating pressures, temperatures and speeds are correct and that the control and shutdown devices function correctly.

## 1.6 TOOL APPLICATIONS SAFETY

Apply the proper tool for each job. With the knowledge of correct tool use and knowing the limitations of tools, along with some common sense, many accidents can be prevented.

Special service tools are available for specific jobs and should be used when recommended. The use of these tools will save time and prevent damage to parts.

## 1.7 SPECIFIC SAFETY PRECAUTIONS

### Batteries

When servicing batteries, always wear protecting clothing and glasses.

- 1 The electrolyte in batteries is a sulphuric acid solution which is fatal if it hits your eyes, and which can cause burns if it contacts your skin. Therefore, be careful when handling batteries, e.g. when checking the charge condition.
- 2 Install a sign prohibiting fire, open flame and smoking at the post where batteries are being charged.
- 3 When batteries are being charged, an explosive gas mixture forms in the cells and might escape through the vent holes in the plugs. Thus an explosive atmosphere may form around the battery if ventilation is poor, and can remain in and around the battery for several hours after it has been charged. Therefore:
  - never smoke near batteries being, or having recently been, charged,
  - never break live circuits at battery terminals, because a spark usually occurs.
- 4 When connecting an auxiliary battery (AB) in parallel to the unit battery (CB) with booster cables: connect the + pole of AB to the + pole of CB, then connect the - pole of CB to the mass of the unit. Disconnect in the reverse order.

### Pressure vessels

(according to directive 87/404/EEC annex II § 2)

Maintenance/installation requirements:

- 1 The vessel can be used as pressure vessel or as separator and is designed to hold compressed air for the following application:
  - pressure vessel for compressor,
  - medium AIR/OIL,
 and operates as detailed on the data plate of the vessel:
  - the maximum working pressure ps in bar,
  - the maximum working temperature Tmax in °C,
  - the minimum working temperature Tmin in °C,
  - the capacity of the vessel V in l.
- 2 The pressure vessel is only to be used for the applications as specified above and in accordance with the technical specifications. Safety reasons prohibit any other applications.
- 3 National legislation requirements with respect to re-inspection must be complied with.
- 4 No welding or heat treatment of any kind is permitted to those vessel walls which are exposed to pressure.
- 5 The vessel is provided and may only be used with the required safety equipment such as manometer, overpressure control devices, safety valve, etc.
- 6 Draining of condensate shall be performed regularly when vessel is in use.
- 7 Installation, design and connections should not be changed.
- 8 Bolts of cover and flanges may not be used for extra fixation.

### Safety valves

All adjustments or repairs are to be done by an authorized representative of the valve supplier (see maintenance schedule).

# ORDERING SPARE PARTS

## **ORDERING SPARE PARTS**

Always quote the part number, the designation and the quantity of the parts required, as well as the type and the serial number of the machine.

### **EXPLANATION OF THE COLUMNS**

#### **REF : REFERENCE CODE**

Establishes the connection between a part in the list and a part in the illustration.

"-" means that the part is not shown in the illustration.

#### **PART NUMBER**

If no part number is given, the part cannot be obtained as a spare part. Parts marked with a dot are part of the assembly listed right above them.

#### **DESIGNATION**

Usually this is the name of the part. For standard parts, in addition to the name, a number of characteristics are given.

#### **QTY : QUANTITY**

Indicates the quantity of the part concerned. "AR" stands for "As Required".

## **BESTELLEN VAN ONDERDELEN**

Vermeld steeds het onderdeelnummer, de benaming en het aantal van de gewenste stukken, evenals het type en het serienummer van de machine.

### **TOELICHTING BIJ DE KOLOMMEN**

#### **REF : REFERENTIECODE**

Legt het verband tussen een onderdeel uit de lijst en een onderdeel op de tekening. "-" betekent dat het onderdeel niet is getekend.

#### **PART NUMBER : ONDERDEELNUMMER**

Indien niet opgegeven is het onderdeel niet als wisselstuk beschikbaar. Onderdelen aangeduid met een stip maken deel uit van het geheel dat boven de betreffende onderdelen staat.

#### **DESIGNATION : BENAMING**

Meestal de benaming van het onderdeel. In het geval van standaard onderdelen worden naast de benaming een aantal karakteristieken opgegeven.

#### **QTY : AANTAL**

Geeft de hoeveelheid van het betreffende onderdeel weer. De aanduiding "AR" betekent "As Required" (zoals vereist).

## **COMMANDE DE PIÈCES DETACHEES**

Toujours indiquer le numéro de pièce, la désignation, la quantité désirée ainsi que le type et le numéro de série du groupe.

### **EXPLICATION DES INTITULES DES COLONNES**

#### **REF : CODE DE REFERENCE**

Réfère à la pièce détachée spécifiée dans la liste et sur l'illustration. "-" implique que la pièce n'est pas indiquée sur l'illustration.

#### **PART NUMBER : NUMERO DE PIECE DETACHEE**

Si le numéro n'est pas indiqué, la pièce n'est pas disponible en tant que pièce de rechange.

Les pièces indiquées par un point gras font partie de l'ensemble se trouvant au-dessus des pièces détachées correspondantes.

#### **DESIGNATION**

En général, le nom de la pièce. S'il s'agit de pièces standard, outre la désignation, un certain nombre de caractéristiques sont indiquées.

#### **QTY : QUANTITE**

Indique la quantité de la pièce détachée. "AR" indique "As required", c'est-à-dire la quantité à déterminer selon le cas.

## **BESTELLUNG VON ERSATZTEILEN**

Stets die Teilenummer, die Bezeichnung, und die Anzahl der gewünschten Teile sowie den Typ und die Seriennummer der Maschine angeben.

### **INFORMATION ZU DEN SPALTEN**

#### **REF : REFERENZCODE**

Stellt die Verbindung zwischen einem Teil in der Liste und einem Teil auf der Zeichnung her. "-" bedeutet, daß das Teil nicht in der Zeichnung dargestellt ist.

#### **PART NUMBER : TEILENUMMER**

Wenn keine Teilenummer angegeben ist, ist das Teil nicht als Ersatzteil erhältlich.

Mit einem Punkt markierte Teile gehören zu der Einheit, die über den jeweiligen Teilen aufgeführt ist.

#### **DESIGNATION : BEZEICHNUNG**

Meistens die Bezeichnung des Teils. Bei Standardteilen werden neben der Bezeichnung einige technische Daten angegeben.

#### **QTY : ANZAHL**

Gibt die Anzahl des betreffenden Teils an. Die Angabe "AR" steht für "As Required" (wie erforderlich).

## **PEDIDO DE PARTES**

Siempre comunicar el número de parte, la designación y la cantidad deseada así como el tipo y el número de serie de la máquina.

### **INFORMACIONES SOBRE LAS COLUMNAS**

#### **REF : CODIGO DE REFERENCIA**

Establece la conexión entre una parte en la lista y una parte en la ilustración.

"-" quiere decir que la parte no está ilustrada.

#### **PART NUMBER : NUMERO DE PARTE**

Si no se da ningún número, quiere decir que la parte no está disponible como parte de recambio.

Partes marcadas con un punto son partes del conjunto indicado más arriba.

#### **DESIGNATION : DESIGNACION**

Principalmente el nombre de la parte. En caso de partes estándares, el nombre es seguido por especificaciones.

#### **QTY : CANTIDAD**

Indica la cantidad de la parte correspondiente. La indicación "AR" significa "As Required" (como sea requerido).

## **BESTÄLLNING AV RESERVDLAR**

Ange alltid reservdelsnummer, benämning och kvantitet för varje önskad detalj samt maskinens typ och tillverkningsnummer.

### **TÖRKLARING AV SPALTER**

#### **REF : REFERENSNUMMER**

Identifierar motsvarande detaljer i listan och illustrationen. "-" betyder att detaljen inte visas i illustrationen.

#### **PART NUMBER : RESERVDLSNUMMER**

Om inget reservdelsnummer anges, kan detaljen inte erhållas som reservdel. Detaljer som anges med en punkt ingår i den monteringsatts som listas ovanför dessa.

#### **DESIGNATION : BENÄMNING**

Detta är vanligen namnet på detaljen. För standarddetaljer anges förutom namnet ett antal specifikationer.

#### **QTY : KVANTITET**

Anger den ifrågavarande detaljens kvantitet. "AR" (As Required) betyder enligt behov.

# ORDERING SPARE PARTS

## **ORDINAZIONE DI PARTI DI RICAMBIO**

Menzionare sempre il numero della parte, la denominazione e il numero de pezzi desiderati, nonché il tipo e il numero di serie della macchina.

### **SPIEGAZIONE DELLE COLONNE**

#### **REF : CODICE DI RIFERIMENTO**

Stabilisce il nesso tra un pezzo nell'elenco e un pezzo nell'illustrazione. "-" significa che il pezzo non è presente nell'illustrazione.

#### **PART NUMBER : NUMERO DELLA PARTE**

Nel caso non sia fornito il numerom di parte, il pezzo non può essere ordinato come parte di ricambio.

Il componenti indicati con un puntino fanno parte del gruppo elencato immediatamente sopra di essi.

#### **DESIGNATION : DENOMINAZIONE**

Generalmente si tratta della denominazione della parte. Per i pezzi standard oltre alla denominazione sono fornite alcune caratteristiche.

#### **QTY : QUANTITA'**

Indica la quantità dei pezzi in questione. "AR" significa "As Required" (Come richiesto).

## **ΠΑΡΑΓΓΕΛΙΑ ΑΝΤΑΛΛΑΚΤΙΚΩΝ**

Πάντοτε σημειώνετε τον κωδικό, τον προσδιορισμό και την ποσότητα των απαιτούμενων ανταλλακτικών, καθώς επίσης τον τύπο και τον αύξοντα κωδικό αριθμό παραγωγής του μηχανήματος.

### **ΕΞΗΓΗΣΗ ΤΩΝ ΣΤΗΛΩΝ**

#### **REF : ΚΩΔΙΚΟΣ ΑΝΑΦΟΡΑΣ**

Παρουσιάζει τη σχέση μεταξύ ενός εξαρτήματος στη λίστα και ενός εξαρτήματος στη φωτογραφία. Το "-" σημαίνει ότι το εξάρτημα δεν εμφανίζεται στη φωτογραφία.

#### **PART NUMBER : ΚΩΔΙΚΟΣ ΑΡΙΘΜΟΣ**

Αν δεν δίνεται κάποιος κωδικός αριθμός, τότε το εξάρτημα δεν μπορεί να ληφθεί ως ανταλλακτικό.

Τα εξαρτήματα που έχουν μαρκαρισθεί με μία τελεία είναι τμήματα του συγκροτήματος που παρουσιάζεται ακριβώς πάνω από αυτά.

#### **DESIGNATION : ΠΡΟΣΔΙΟΡΙΣΜΟΣ**

Συνήθως αυτό είναι το όνομα του εξαρτήματος. Για τα βασικά εξαρτήματα, επιπροσθέτα στην ονομασία, δίνεται και ένας αριθμός χαρακτηριστικών.

#### **QTY : ΠΟΣΟΤΗΤΑ**

Δηλώνει την ποσότητα του υπόψη εξαρτήματος. "AR" σημαίνει "Ως απαιτείται". Για τα βασικά εξαρτήματα, η ποσότητα δίνεται στη φωτογραφία παρά στη λίστα.

## **BESTÄLLNING AV RESERVDLAR**

Ange alltid reservdelsnummer, benämning och kvantitet för varje önskad detalj samt maskinens typ och tillverkningsnummer.

### **TÖRKLARING AV SPALTER**

#### **REF : REFERENSNUMMER**

Identifierar motsvarande detaljer i listan och illustrationen. "-" betyder att detaljen inte visas i illustrationen.

#### **PART NUMBER : RESERVDLSNUMMER**

Om inget reservdelsnummer anges, kan detaljen inte erhållas som reservdel. Detaljer som anges med en punkt ingår i den monteringsatts som listas ovanför dessa.

#### **DESIGNATION : BENÄMNING**

Detta är vanligen namnet på detaljen. För standarddetaljer anges förutom namnet ett antal specifikationer.

#### **QTY : KVANTITET**

Anger den ifrågavarande detaljens kvantitet. "AR" (As Required) betyder enligt behov.

## **ONCOMENDAS DE PEÇAS**

Refira sempre o número da peça, a designação e a quantidade das peças que pretende encomendar, assim como o tipo e o número de série do aparelho.

### **EXPLICAÇÃO DAS COLUNAS**

#### **REF : CÓDIGO DE REFERÊNCIA**

Estabeleça a ligação entre a peça na lista e a peça no desenho. "-" significa que a peça não vem no desenho.

#### **PART NUMBER : NÚMERO DA PEÇA**

Se não vier referido o número da peça, a peça não pode ser adquirida como peça sobressalente.

As peças marcadas com pontos são peças de um conjunto listado acima dessa peça.

#### **DESIGNATION : DESIGNAÇÃO**

Geralmente é o nome da peça. Para peças normalizadas, além do nome da peça, vem também referido um número.

#### **QTY : QUANTIDADE**

Indica a quantidade da peça em questão. "AR" (As Required) quer dizer "Como solicitado".

## **BESTILLING AV RESERVEDELER**

Opggi alltid delenummer, betegnelse og antall på de delene du trenger, samt maskintype og serienummer.

### **FORKLARING TIL SPALTENE**

#### **REF: REFERANSEKODE**

Viser hvor en del i listen er vist på illustrasjonen. "-" betyr at delen ikke er vist på illustrasjonen.

#### **DELENUMMER**

Hvis delenummer ikke er oppgitt, kan delen ikke bestilles som reservedel. Deler merket med en prikk er del av enheten som er oppgitt like ovenfor de aktuelle delene.

#### **BETEGNELSE**

Dette er vanligvis delens navn. Ved standarddeler blir enkelte karakteristika oppgitt i tillegg til navnet.

#### **QTY: ANTALL**

Opggir antallet av den aktuelle delen. "EB" betyr "Etter behov".

## **VARAOSIEN TILAAMINEN**

Tilauksessa tulee aina mainita osanumero, nimike ja määrä sekä kompressorin tyyppi ja sarjanumero.

### **SARAKKEIDEN SELITYKSET**

#### **REF: VIITE: VIITEKOODI**

Viitekoodi yhdistää luettelossa mainitun osan kuvassa olevaan. "-" tarkoittaa, että osaa ei ole merkitty kuvaan.

#### **PART NUMBER: OSANUMERO**

Ellei osanumeroa ole mainittu, osaa ei ole saatavana varaosana. Pisteellä merkityt osat kuuluvat niiden edellä mainittuun asennelmaan.

#### **DESIGNATION: NIMIKE**

Nimikkeenä käytetään tavallisesti osan nimeä. Vakio-osien ollessa kyseessä mainitaan nimen lisäksi osan joitakin ominaisuuksia.

#### **QTY: MÄÄRÄ**

Tarkoittaa kyseisten osien lukumäärää. "AR" tarkoittaa "tarpeen mukaan".

# ORDERING SPARE PARTS

## **ZAMAWIANIE CZĘŚCI ZAMIENNYCH**

Należy zawsze podawać numery, nazwy i ilości potrzebnych części, a także typ i numer seryjny maszyny.

## **WYJAŚNIENIE PRZEZNACZENIA KOLUMN**

### **REF: KOD REFERENCYJNY**

Kojarzy część na liście z częścią na ilustracji. Symbol “-” oznacza, że część nie jest przedstawiona na ilustracji.

### **PART NUMBER (NUMER CZĘŚCI)**

Brak numeru oznacza, że dana część nie jest dostępna jako część zamienna.

Części oznaczone kropką należą do zespołu wymienionego bezpośrednio nad nimi.

### **DESIGNATION (NAZWA)**

Zwykle jest to nazwa części. W przypadku części standardowych oprócz nazwy podano szereg właściwości.

### **QTY (IL.): ILOŚĆ**

Pość części danego rodzaju. “AR” (“OP”) oznacza “odpowiednio do potrzeb”.

## **Заказ запасных частей**

Необходимо всегда указывать номер детали, наименование и количество заказываемых запчастей, а также тип и серийный номер устройства.

## **Расшифровка столбцов**

### **ИЛЛ. : код сноски**

Показывает ссылку детали в списке на ее соответствующую иллюстрацию.

“-” означает, что к данной детали нет иллюстраций.

### **НОМЕР ДЕТАЛИ**

Отсутствие номера детали означает, что данная деталь как запчасть не поставляется.

Детали, помеченные точкой, являются частями сборного механизма, который указан над этими деталями.

### **НАИМЕНОВАНИЕ**

Обычно, название детали. К стандартным деталям, кроме названия, могут быть даны некоторые их характеристики.

### **КОЛ-ВО: Количество**

Показывает количество деталей. «По тр.» означает «по требованию».

## **OBJEDNÁVÁNÍ NÁHRADNÍCH DÍLŮ**

V objednávce vždy uveďte číslo dílu, jeho označení a požadované množství. Rovněž tak udejte typ a výrobní číslo zařízení.

## **VYSVĚTLIVKY K JEDNOTLIVÝM SLOUPCŮM**

### **REF : REFERENČNÍ KÓD**

Udává spojitost mezi dílem v seznamu a dílem na obrázku. “-” znamená, že díl není na obrázku uveden.

### **ČÍSLO DÍLU**

Pokud není číslo dílu uvedeno, nelze tuto součást objednat jako náhradní díl.

Díly označené tečkami jsou součástí konstrukčního celku, který je uveden přímo nad nimi.

### **OZNAČENÍ**

Ve sloupci označení bývá obvykle uveden název dílu. U standardních součástí je vedle názvu uváděna též řada dalších charakteristik.

### **POĚT : MNOŽSTVÍ**

Označuje množství uvedených dílů. Zkratka “PP” znamená “Podle požadavku”.

## **PÓTALKATRÉSZ-RENDELÉS**

Mindig jelezze a szükséges alkatrész számát, megnevezését és mennyiségét, valamint a gép típusát és sorozatszámát.

## **AZ OSZLOPOK MAGYARÁZATA**

### **REF: REFERENCIAKÓD**

Ez teremt kapcsolatot a listán szereplő alkatrész és az ábrán látható alkatrész között.

“-”: azt jelenti, hogy az adott alkatrész nem szerepel az ábrán.

### **ALKATRÉSZ-SZÁM**

Ha nincsen megadva alkatrész-szám, akkor az adott alkatrész nem rendelhető meg pótalkatrészként.

A ponttal jelölt alkatrészek a közvetlenül fölöttük felsorolt szerelvény részét képezik.

### **MEGNEVEZÉS**

Rendszerint ez az alkatrész neve. Az alapfelszereltséghez tartozó alkatrészek esetében a név mellett néhány jellemző adat is szerepel.

### **QTY: MENNYISÉG**

Az adott alkatrész mennyiségét jelzi. “SZ” jelentése “Szükség szerint”

## **订购备件**

请务必提供所需部件的部件号、名称和数量，以及设备型号和序列号。

## **表格各列说明**

### **REF: 参考代码**

确立列表内部件与插图内部件间的联系。

“-”表示插图内未显示此部件。

### **部件号**

如果未给出部件号，则表明无法通过备件方式购买此部件。标有圆点的部件是其上一行所列配件的一部分。

### **名称**

通常为部件的名称。对于标准件，除了名称外，还会列出它的一些特性。

### **QTY: 数量**

表明可供部件的数量。“AR”代表“根据需要”

## **OBJEDNÁVANIE NÁHRADNÝCH SÚČIASTOK**

Uvádajte vždy číslo súčiastky, označenie a množstvo požadovaných súčiastok, ako aj typ a výrobné číslo stroja.

## **VYSVETLENIE STŮPCOV**

### **REF : REFERENČNÝ KÓD**

Stanovuje spojitost medzi súčiastkou v zozname a súčiastkou na obrázku. “-” znamená, že súčiastka nie je zobrazená na obrázku.

### **ČÍSLO SÚČIASTKY**

Ak nie je uvedené žiadne číslo súčiastky, táto súčiastka nie je k dispozícii ako náhradná.

Súčiastky označené bodkou sú časťou zostavy uvedenej hneď nad nimi.

### **OZNAČENIE**

Obyčajne je to názov súčiastky. U normalizovaných súčiastok sa okrem názvu uvádza aj niekoľko charakteristík

### **QTY : MNOŽSTVO**

Označuje množstvo danej súčiastky. “AR” je skratka pre “Podľa potreby”.

# ORDERING SPARE PARTS

## NAROČEVANJE NADOMESTNIH DELOV

Zmeraj navedite številko nadomestnega dela, označbo in količino potrebnih delov ter tip in serijsko številko stroja.

### RAZLAGA STOLPCEV

*REF : REFERENČNA ŠIFRA*

Predstavlja povezavo med delom na seznamu in delom na ilustraciji. "-" predstavlja del, ki ni prikazan na ilustraciji.

### ŠTEVILKA DELA

Če številka dela ni podana potem je ne morete dobiti kot nadomestni del. Deli označeni s piko so sestavni del montaže, navedene nad njimi.

### OZNAČBA

Običajno je to ime nadomestnega dela. Pri standardnih delih je poleg imena podano še število značilnosti.

### *QTY : KOLIČINA*

Označuje količino nadomestnih delov. "AR" pomeni "kot je bilo zahtevano".

## ATSARGINIŲ DALIŲ UBSAKYMAS

Visuomet nurodykite dalies numerą, pavadinimą ir reikiamą dalių kieką, taip pat ir mašinos tipą bei serijinį numerą.

### STULPELIŲ PAAIŖKINIMAI

*NRD.: NUORODOS KODAS*

Susieja sąraše nurodytą dalį su jos atvaizdu iliustracijoje. "-" reiškia, jog dalis iliustracijoje nepavaizduota.

### *DALIES NUMERIS*

Jei numerio nenurodyta, detalės negalima įsigyti kaip atsarginės dalies. Tađku pažymėtos dalys yra prieš jas sąraše nurodyto mazgo sudėtinė dalis.

### *PAVADINIMAS*

Paprastai tai dalies pavadinimas. Standartinėms dalims kartu su pavadinimu nurodomos ir kelios charakteristikos.

### *KIEK.: KIEKIS*

Nurodo susijusių dalių kieką. "AR" reiškia "As required" (pagal poreiką).

## VARUOSADE TELLIMINE

Alati viidake osa numbrile, tähisele ja vajalikule osade kogusele, samuti masina tüübile ja seerianumbrile.

### SELGITUS VEERGUDE KOHTA

*REF : VIITENUMBER*

Loob seose nimekirjas toodud osa ja illustratsioonil esitatud osa vahel. "-" tähendab, et illustratsioonil ei ole seda osa kujutatud.

### *OSA NUMBER*

Kui osa numbrit ei ole toodud, pole seda osa võimalik varuosana soetada. Punktiga tähistatud osad on nende kohal toodud koostu osaks.

### *TÄHIS*

Tavaliselt on see osa nimetus. Standardosadel on lisaks nimetusele toodud ka tunnusnumber.

### *QTY : KOGUS*

Osutab vastava osa kogusele. "AR" tähendab vajadusel ("As Required").

## REZERVES DAĪŲ PASŪTĪĀNA

Vienmēr miniet daļas numuru, apzīmējumu un nepieciešamo detaļu daudzumu, kā arī mašinas tipu un sērijas numuru.

### AIĻŪ IZSKAIDROJUMS

*REF : ATSAUKSMES KODS*

Izveido saikni starp detaļu sarakstā un detaļu uz attēla. "-" nozīmē, ka detaļa nav attēlota ilustrācijā.

### *DETAĪĀS NUMURS*

Ja detaļas numurs nav minēts, tad detaļu nevar iegūt kā rezerves daļu. Ar punktu apzīmētās detaļas ir mezgla sastāvdaļas, kurās ir attēlots tieši virs tām.

### *APZĪMĶJUMS*

Parasti tas ir detaļas nosaukums. Standarta detaļām, papildus nosaukumam, tiek minēta virkne raksturojumu \ specifikāciju.

### *QTY : DAUDZUMS*

Norāda domātās detaļas daudzumu. "AR" nozīmē "As Required" – "kā nepieciešams".



# SERVICE PAK

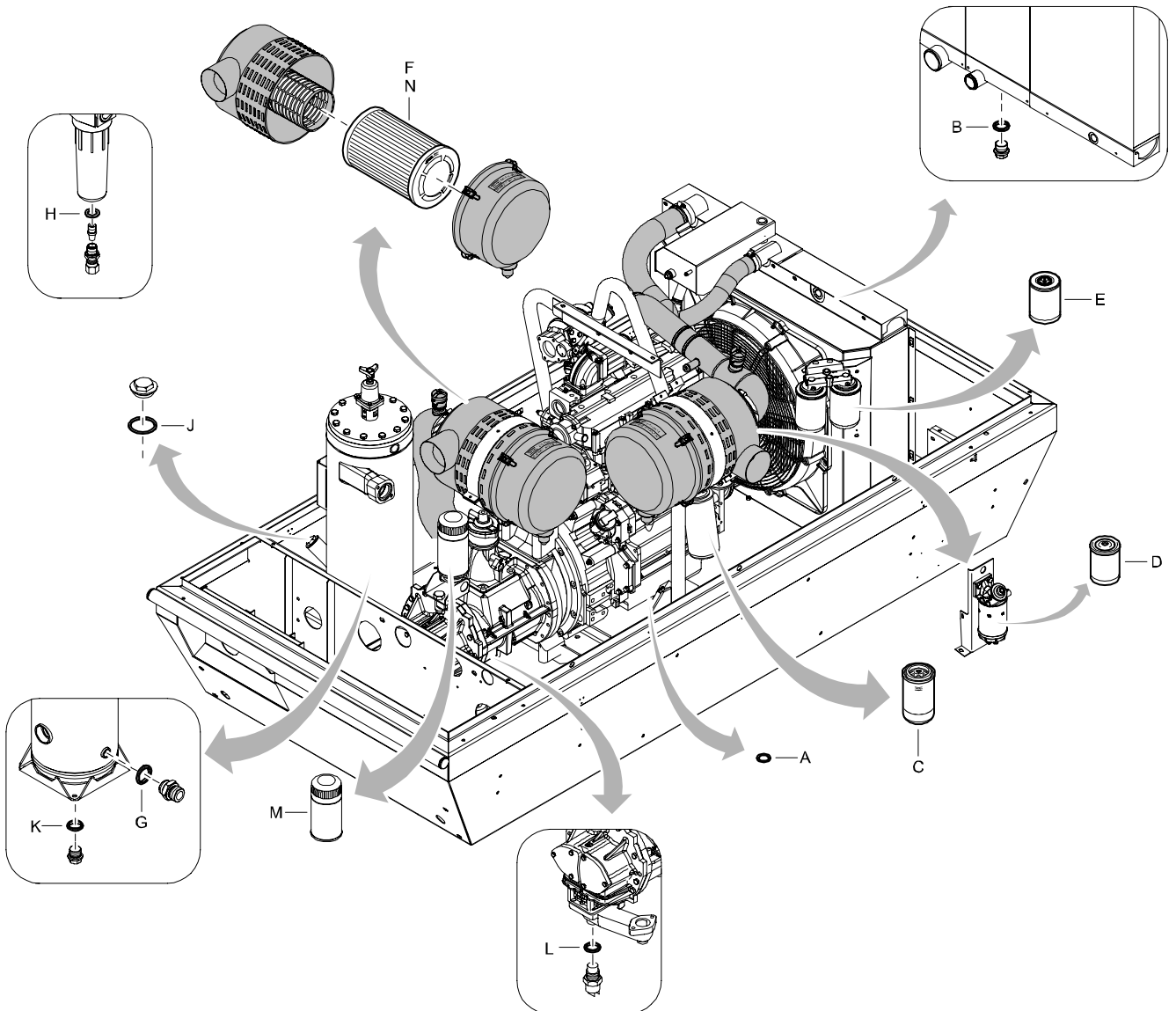

REF	PART NUMBER	DESIGNATION	QTY	REF	PART NUMBER	DESIGNATION	QTY
-	2912 4473 05	KIT SERVICE		•L	-	SEALING WASHER (For details see page 129)	1
•A	-	FLAT GASKET (For details see page 129)	1	•M	-	OILFILTER	1
•C	-	FILTER	1	•N	-	AIR FILTER ELEMENT	1
•E	-	FILTER ELEMENT	2				
•D	-	FUEL FILTER EL.	1	-	2912 4476 06	KIT SERVICE	
•J	-	FLAT GASKET (For details see page 129)	1	•A	-	FLAT GASKET (For details see page 129)	1
				•B	-	SEALING WASHER (For details see page 129)	1
-	2912 4475 06	KIT SERVICE		•C	-	FILTER	1
•A	-	FLAT GASKET (For details see page 129)	1	•D	-	FUEL FILTER EL.	1
•B	-	SEALING WASHER (For details see page 129)	1	•E	-	FILTER ELEMENT	2
•C	-	FILTER	1	•F	-	AIR FILTER ELEMENT	1
•D	-	FUEL FILTER EL.	1	•G	-	SEALING WASHER (For details see page 129)	1
•E	-	FILTER ELEMENT	2	•H	-	FLAT GASKET (For details see page 129)	1
•F	-	AIR FILTER ELEMENT	1	•J	-	FLAT GASKET (For details see page 129)	1
•G	-	SEALING WASHER (For details see page 129)	1	•K	-	SEALING WASHER (For details see page 129)	1
•H	-	FLAT GASKET (For details see page 129)	1	•L	-	SEALING WASHER (For details see page 129)	1
•J	-	FLAT GASKET (For details see page 129)	1	•M	-	OIL FILTER	1
•K	-	SEALING WASHER (For details see page 129)	1	•N	-	AIR FILTER ELEMENT	1

---

# ENGINE OIL

PAROIL 5W40

---

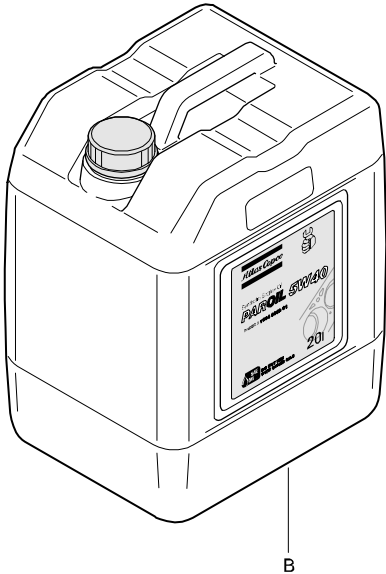

REF	PART NUMBER	DESIGNATION	QTY	REF	PART NUMBER	DESIGNATION	QTY
A	1604 6060 01	PAROIL 5W40 5 LITER CAN	1				
B	1604 6059 01	PAROIL 5W40 20 LITER CAN	1				

---

# ENGINE OIL

## PAROIL 15W40

---

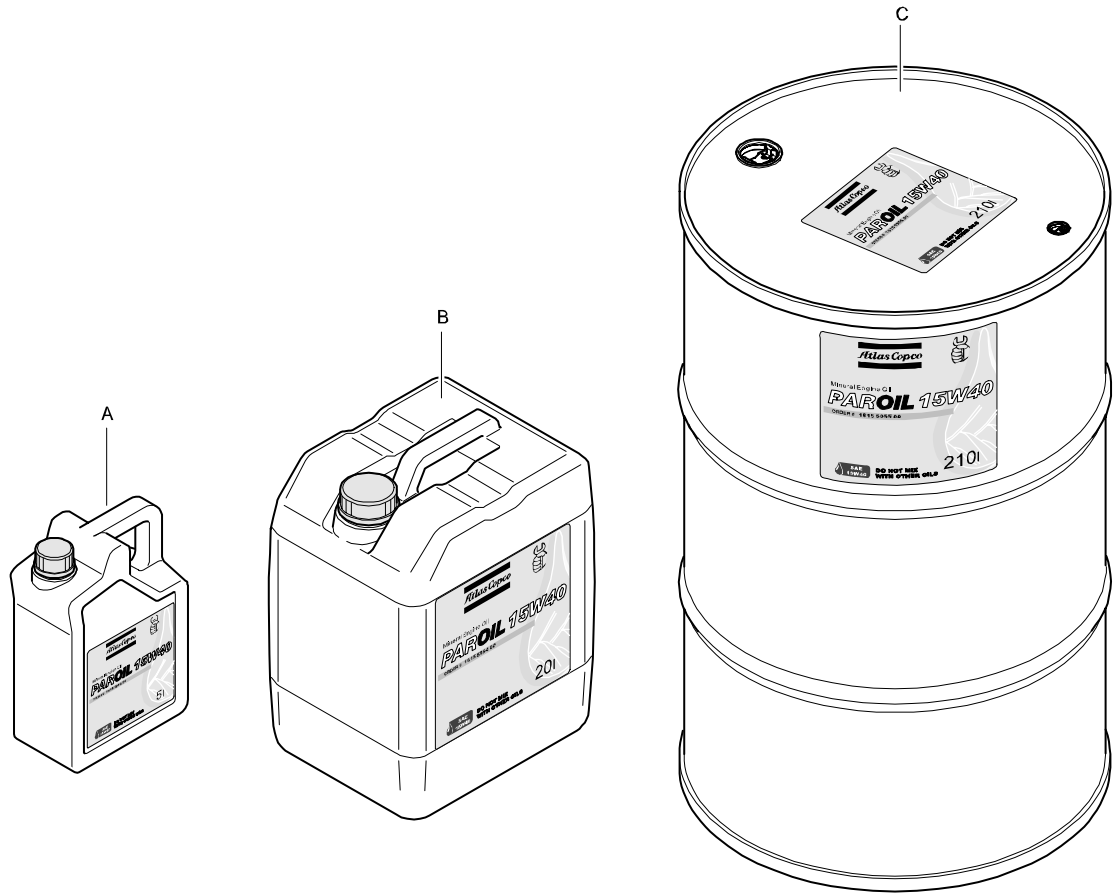

REF	PART NUMBER	DESIGNATION	QTY	REF	PART NUMBER	DESIGNATION	QTY
A	1615 5953 00	PAROIL 15W40 5 LITER CAN	1				
B	1615 5954 00	PAROIL 15W40 20 LITER CAN	1				
C	1615 5955 00	PAROIL 15W40 210 LITER BARREL	1				

---

# COMPRESSOR OIL

## PAROIL M

---

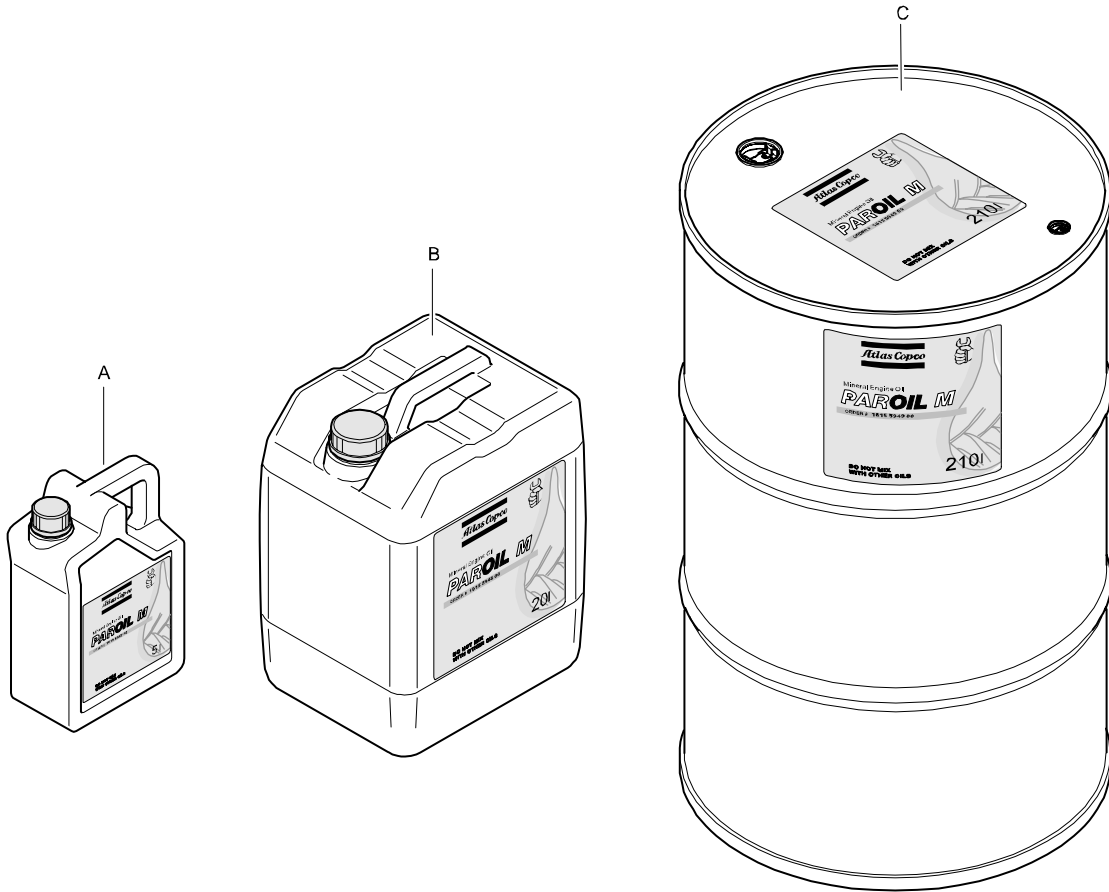

REF	PART NUMBER	DESIGNATION	QTY	REF	PART NUMBER	DESIGNATION	QTY
		<i>PAROIL M</i>					
A	1615 5947 00	OIL CAN 5 L	1				
B	1615 5948 00	OIL CAN 20 L	1				
C	1615 5949 00	STEEL DRUM 210 L	1				

# COMPRESSOR OIL

## PAROIL S

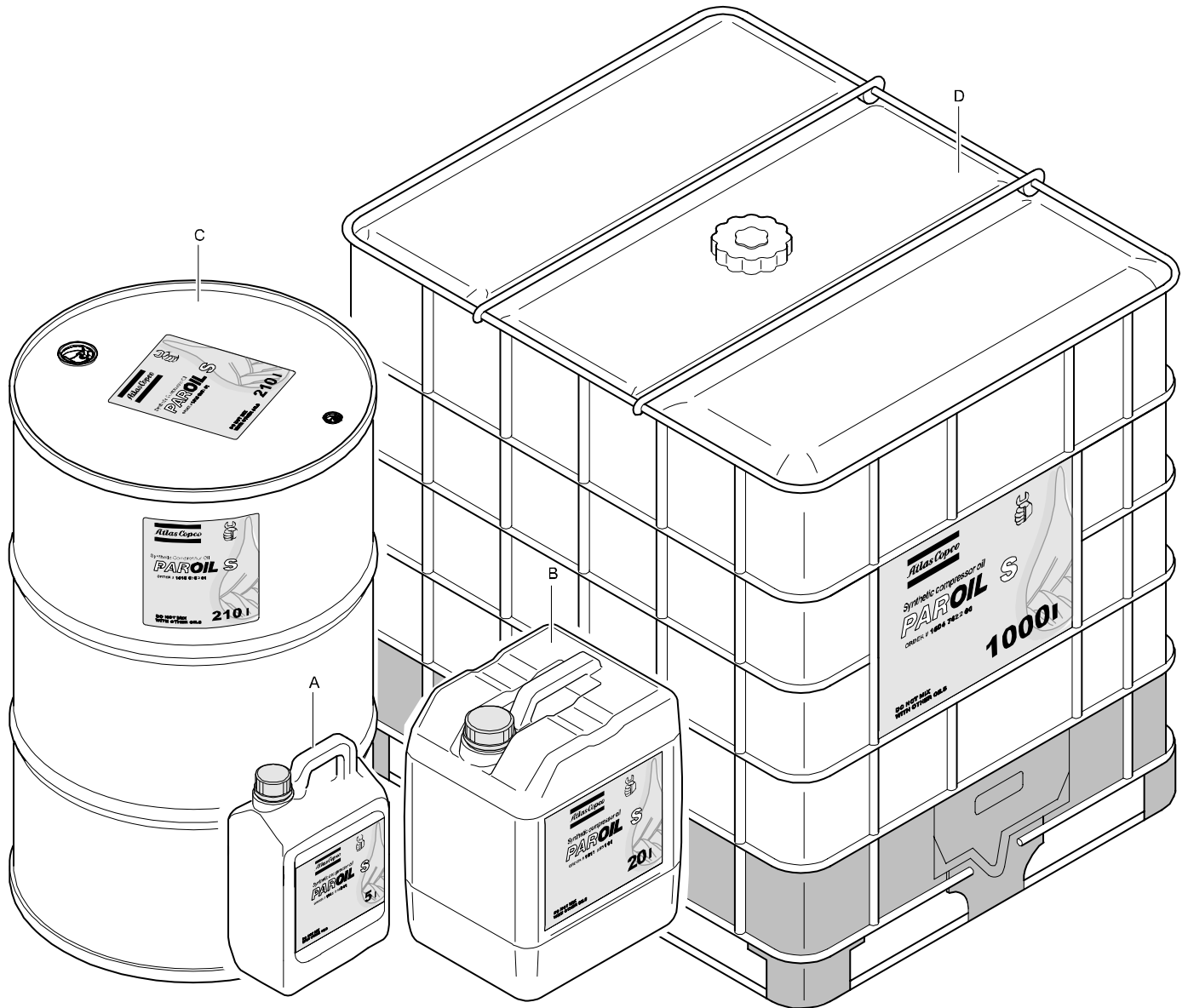

REF	PART NUMBER	DESIGNATION	QTY	REF	PART NUMBER	DESIGNATION	QTY
		<i>PAROIL S</i>					
A	1615 5950 01	OIL CAN 5 L	1				
B	1615 5951 01	OIL CAN 20 L	1				
C	1615 5952 01	STEEL DRUM 210 L	1				
D	1604 7422 00	CONTAINER 1000 L	1				

---

# COMPRESSOR OIL

PAROIL S 68

---

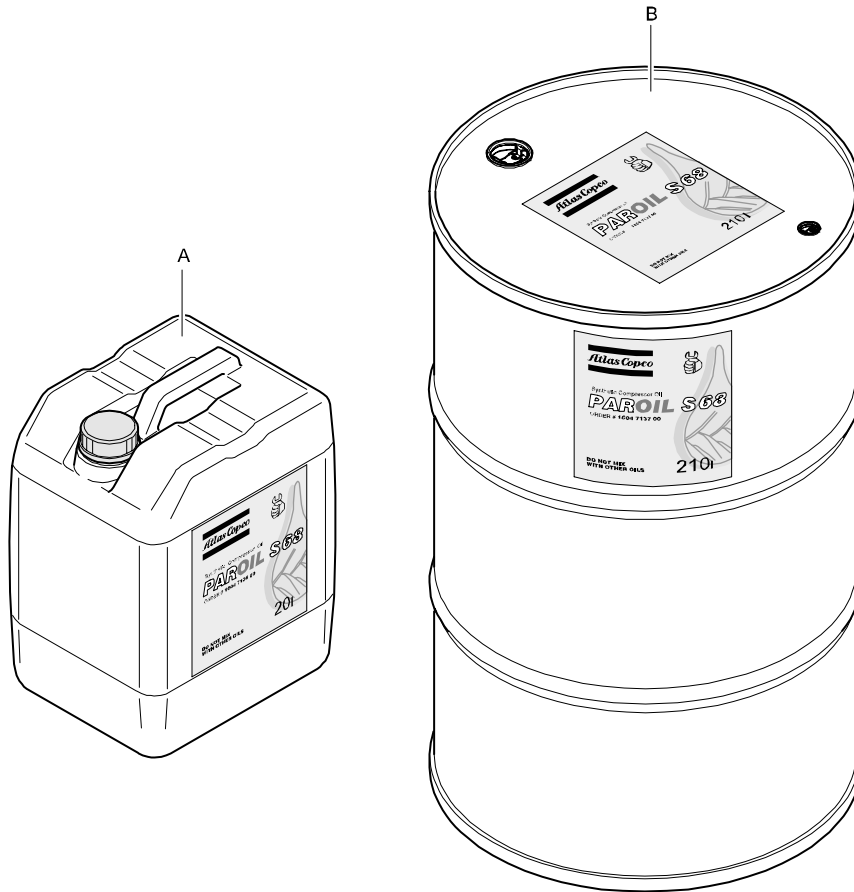

REF	PART NUMBER	DESIGNATION	QTY	REF	PART NUMBER	DESIGNATION	QTY
		<i>PAROIL S 68</i>					
A	1604 7136 00	OIL CAN 20 L	1				
B	1604 7136 00	STEEL DRUM 210 L	1				

---

# ENGINE COOLANT

## PARCOOL EG

---

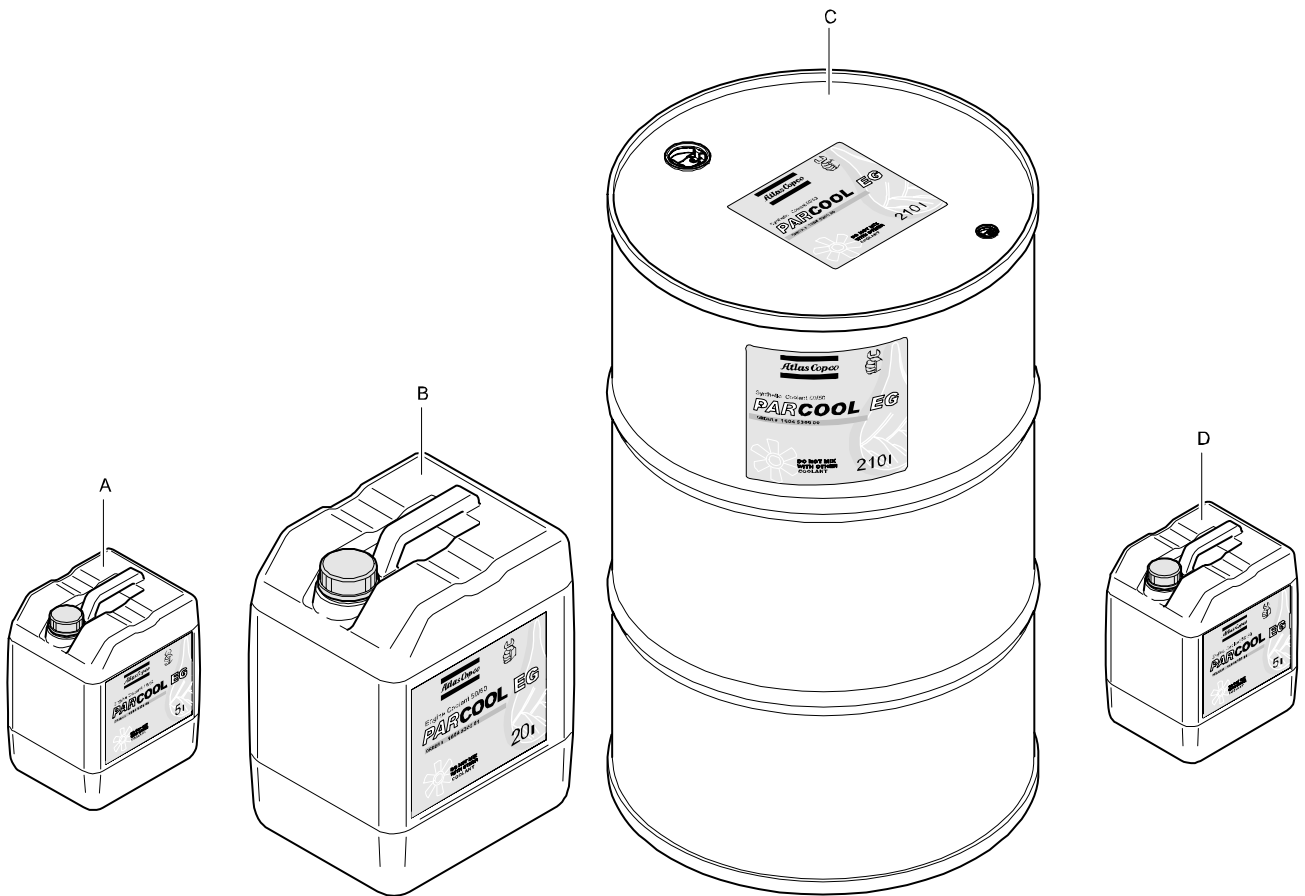

REF	PART NUMBER	DESIGNATION	QTY	REF	PART NUMBER	DESIGNATION	QTY
A	1604 5308 00	PARCOOL EG 5 LITER CAN	1				
B	1604 5307 01	PARCOOL EG 20 LITER CAN	1				
C	1604 5306 00	PARCOOL EG 210 LITER BARREL	1				
D	1604 8159 00	PARCOOL EG CONCENTRATE 5 LITER CAN	1				

# SERVICE KIT

## SPEED REGULATOR

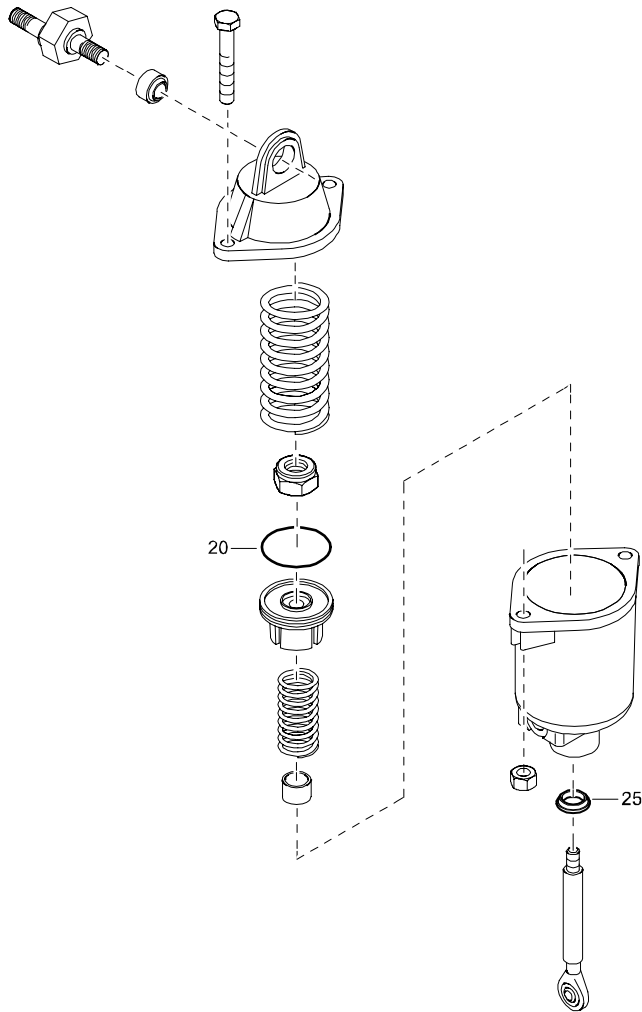

REF	PART NUMBER	DESIGNATION	QTY	REF	PART NUMBER	DESIGNATION	QTY
-	2911 0052 00	SERVICE KIT SPEED REGULATOR					
•20	-	PISTON SEAL	1				
•25	-	WIPER	1				



# SERVICE KIT

## BRAKE SHOES

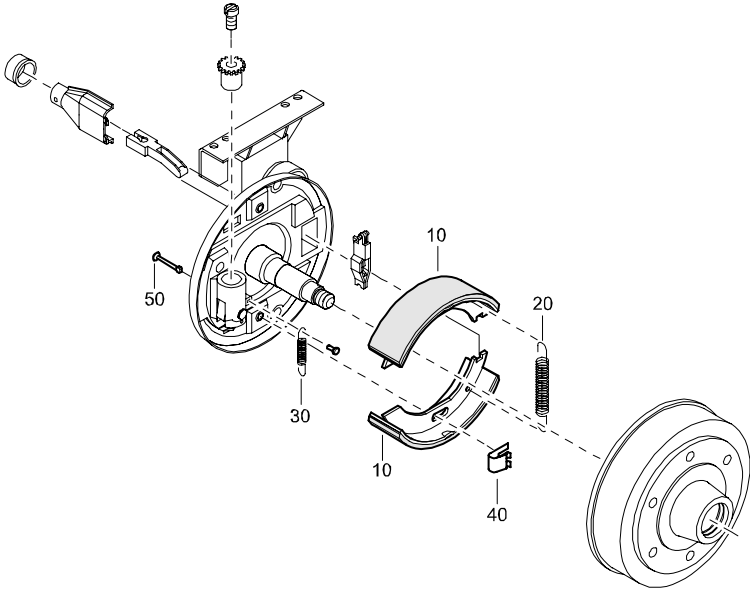

REF	PART NUMBER	DESIGNATION	QTY	REF	PART NUMBER	DESIGNATION	QTY
-	2911 0095 00	SERVICE KIT BRAKE SHOES					
•10	-	BRAKE SHOE	2				
•20	-	SPRING	1				
•30	-	SPRING	1				
•40	-	SPRING	2				
•50	-	PIN	2				

# SERVICE KIT

## UNLOADING VALVE

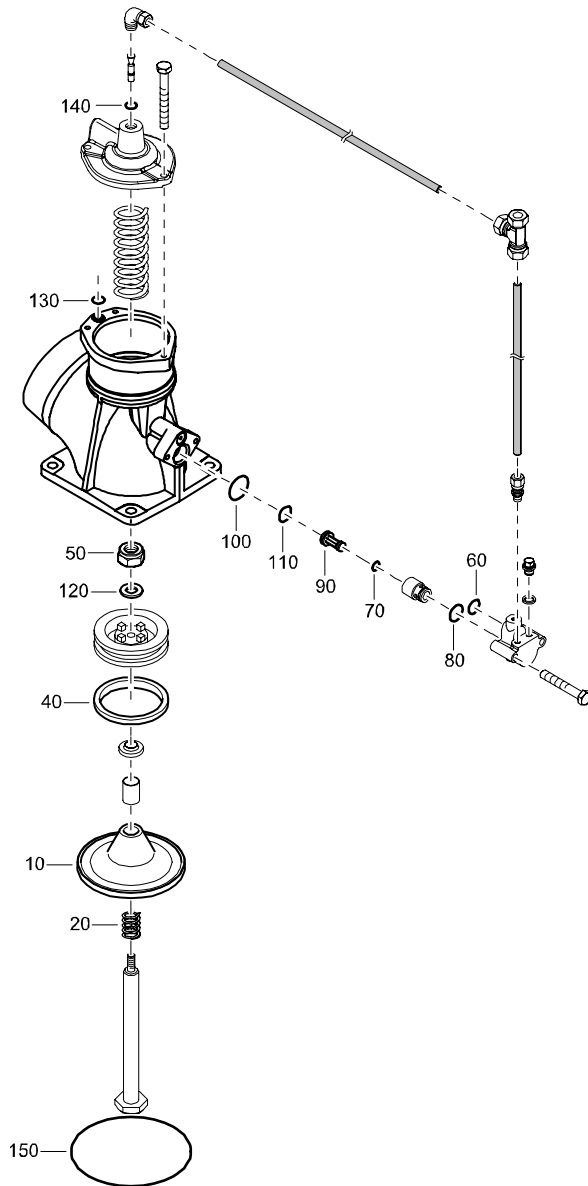

REF	PART NUMBER	DESIGNATION	QTY	REF	PART NUMBER	DESIGNATION	QTY
-	2911 0074 00	SERVICE KIT UNLOADING VALVE					
•10	-	VALVE (UNLOADING)	1				
•20	-	SPRING	1				
•40	-	PISTON SEAL	1				
•50	-	LOCKNUT	1				
•60	-	O-RING	1				
•70	-	O-RING	1				
•80	-	O-RING	1				
•90	-	VALVE	1				
•100	-	O-RING	1				
•110	-	O-RING	1				
•120	-	PLAIN WASHER	1				
•130	-	O-RING	1				
•140	-	O-RING	1				
•150	-	O-RING	1				

# SERVICE KIT

## OIL SEPARATOR

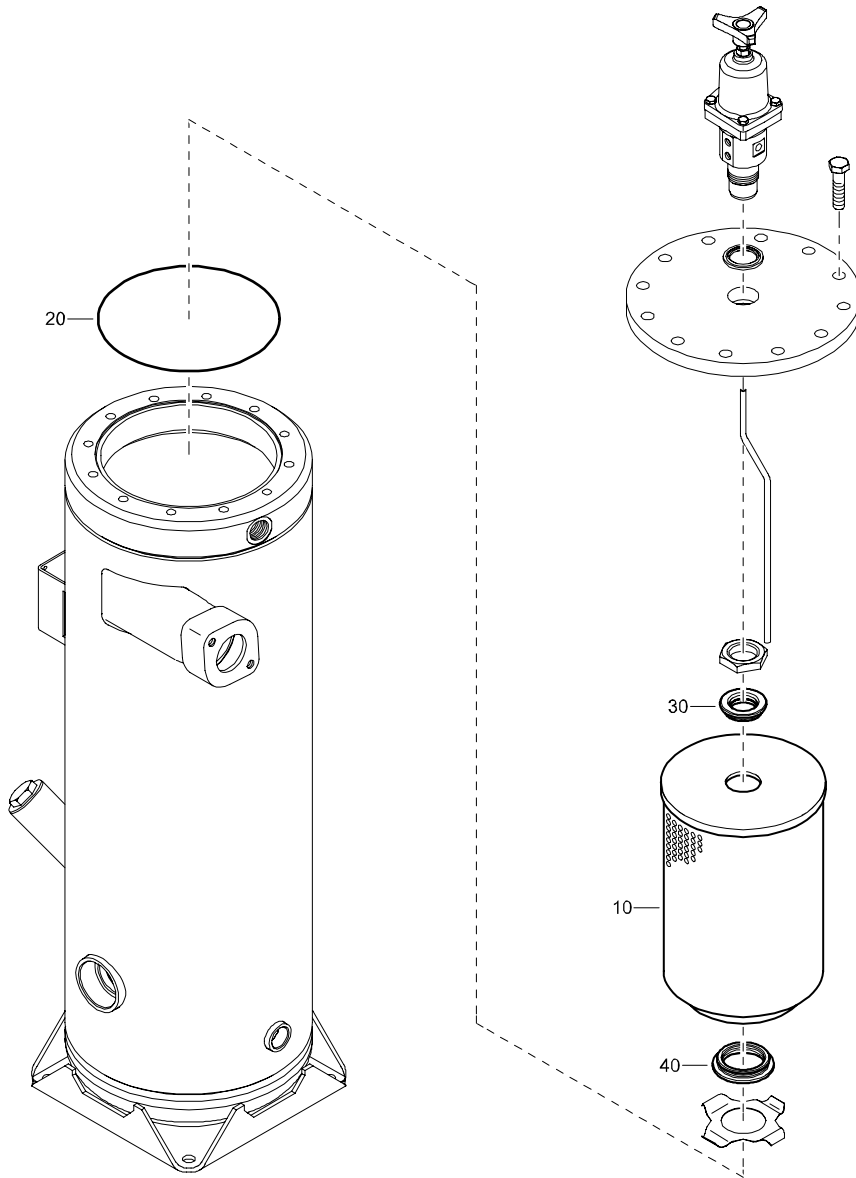

REF	PART NUMBER	DESIGNATION	QTY	REF	PART NUMBER	DESIGNATION	QTY
-	2911 0075 00	SERVICE KIT OIL SEPERATOR					
•10	-	OIL.SEP.ELEMENT	1				
•20	-	O-RING	1				
•30	-	SEAL	1				
•40	-	SEAL (OIL SEPARATOR)	1				

---

# SERVICE KIT

## REGULATING VALVE

---

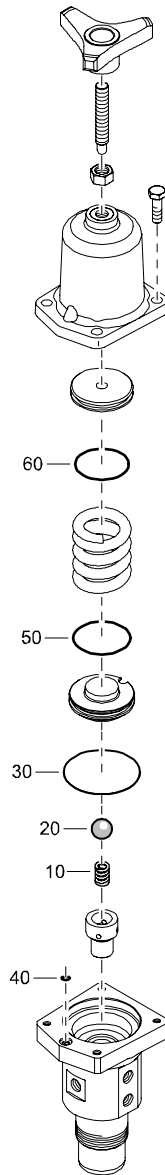

REF	PART NUMBER	DESIGNATION	QTY	REF	PART NUMBER	DESIGNATION	QTY
-	2911 0090 00	REGULATING VALVE KIT					
•10	-	SPRING	1				
•20	-	BEARING BALL	1				
•30	-	MEMBRANE	1				
•40	-	O-RING	1				
•50	-	O-RING	1				
•60	-	O-RING	1				

# SERVICE KIT

## ROAD AXLE BEARINGS

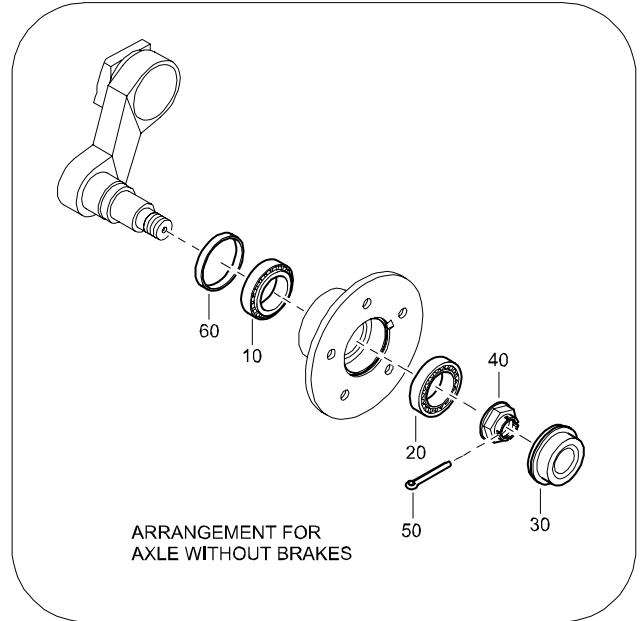
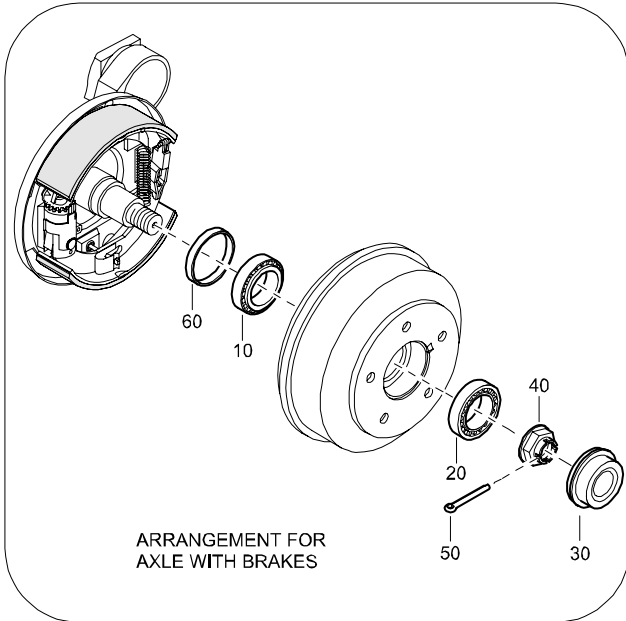

REF	PART NUMBER	DESIGNATION	QTY	REF	PART NUMBER	DESIGNATION	QTY
-	2911 0091 00	SERVICE KIT AXLE BEARINGS					
•10	-	BEARING	1				
•20	-	BEARING	1				
•30	-	CAP	1				
•40	-	CASTLED NUT	1				
•50	-	SPLIT PIN	1				
•60	-	SEAL RING	1				

---

# SERVICE KIT

## LOADING VALVE

---

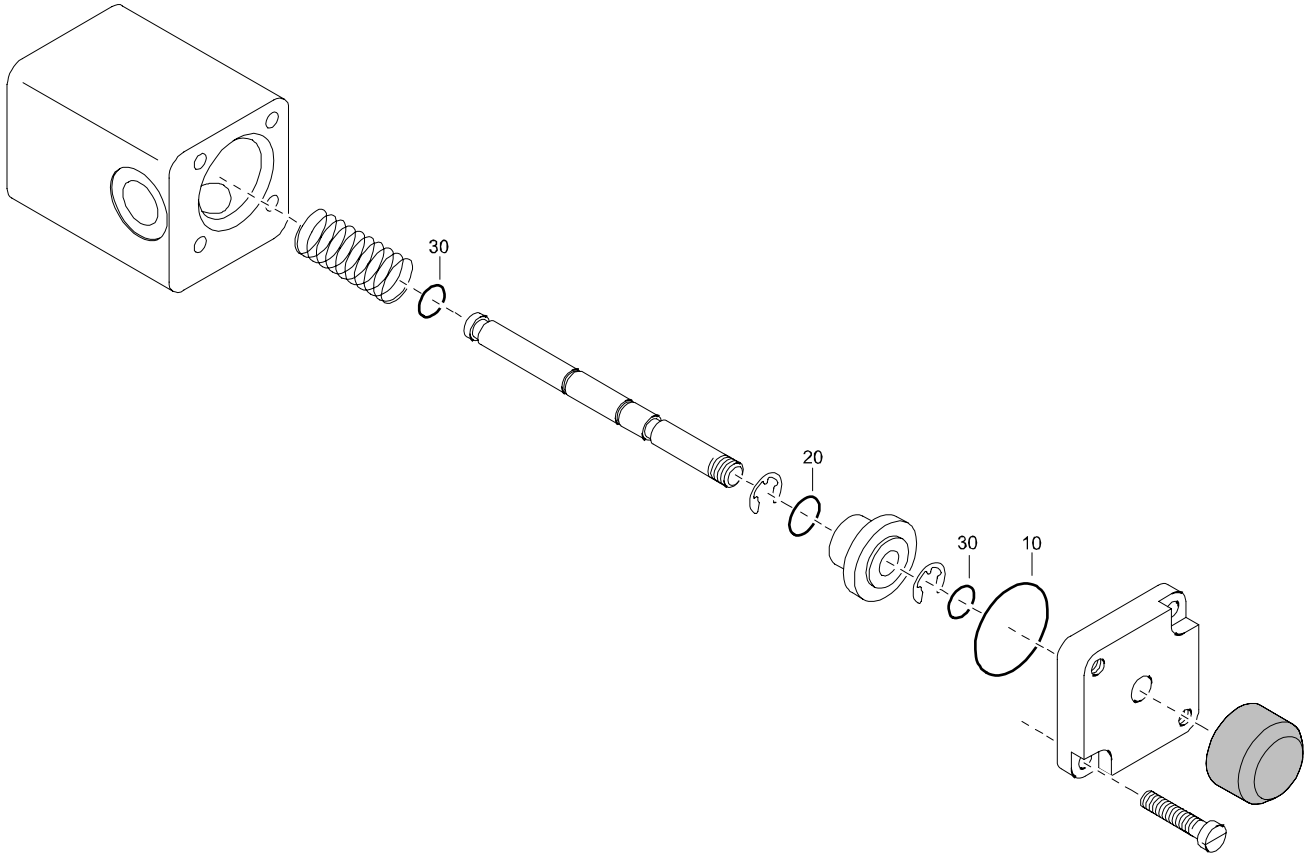

REF	PART NUMBER	DESIGNATION	QTY	REF	PART NUMBER	DESIGNATION	QTY
-	2911 0092 00	SERVICE KIT LOADING VALVE					
•10	-	O-RING	1				
•20	-	O-RING	1				
•30	-	O-RING	2				

# SERVICE KIT

## ELEMENT MOUNTING

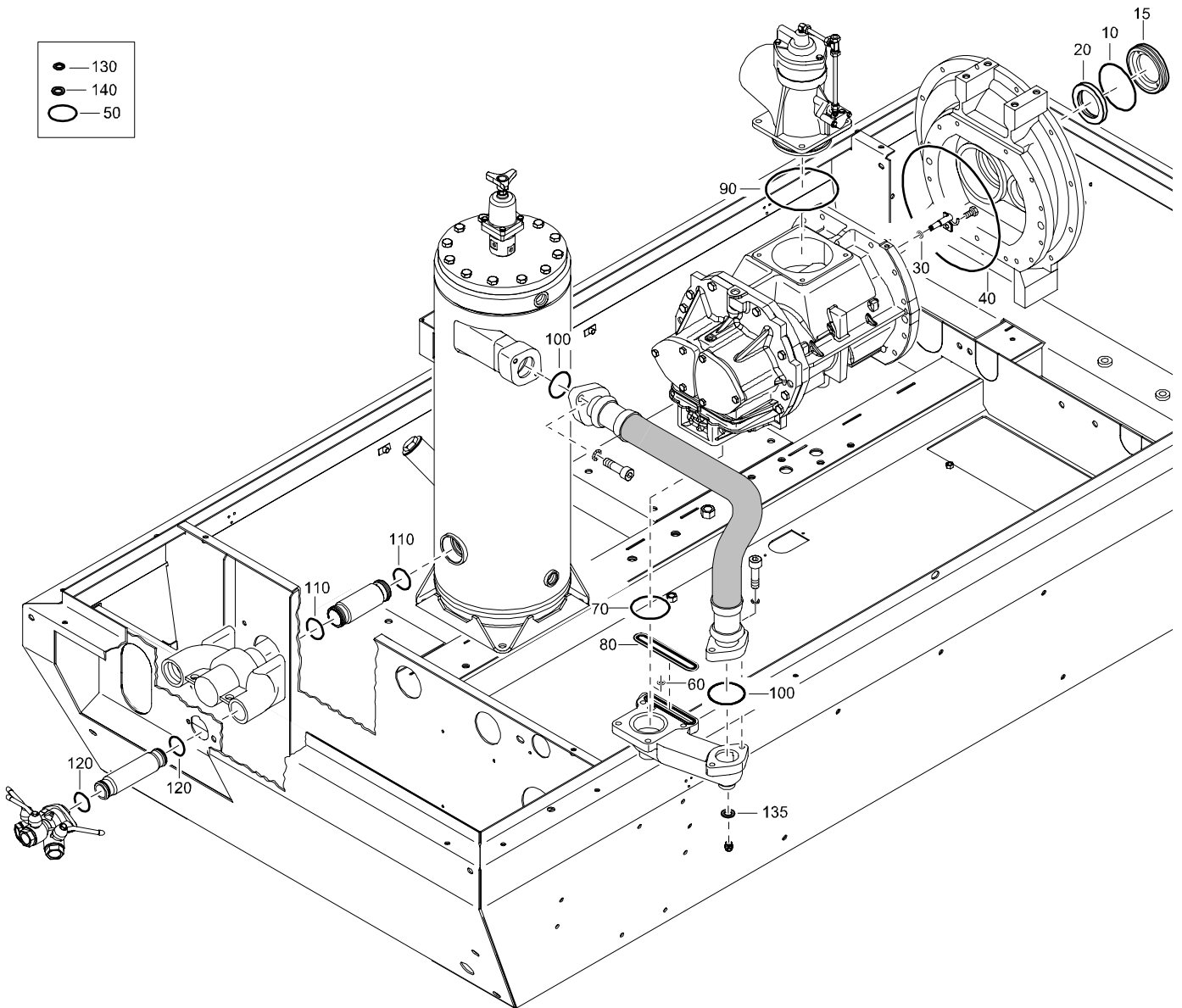

REF	PART NUMBER	DESIGNATION	QTY	REF	PART NUMBER	DESIGNATION	QTY
-	2911 0094 00	SERVICE KIT ELEMENT MOUNTING					
•10	-	O-RING	1				
•15	-	RETAINER	1				
•20	-	LIP SEAL	1				
•30	-	O-RING	1				
•40	-	O-RING	1				
•50	-	O-RING	1				
•60	-	O-RING	1				
•70	-	O-RING	1				
•80	-	SEAL	1				
•90	-	O-RING	1				
•100	-	O-RING	2				
•110	-	O-RING	2				
•120	-	O-RING	2				
•130	-	FLAT GASKET	1				
•135	-	FLAT GASKET	1				
•140	-	FLAT GASKET	1				

# STANDARD

## FRAME AND MOUNTS

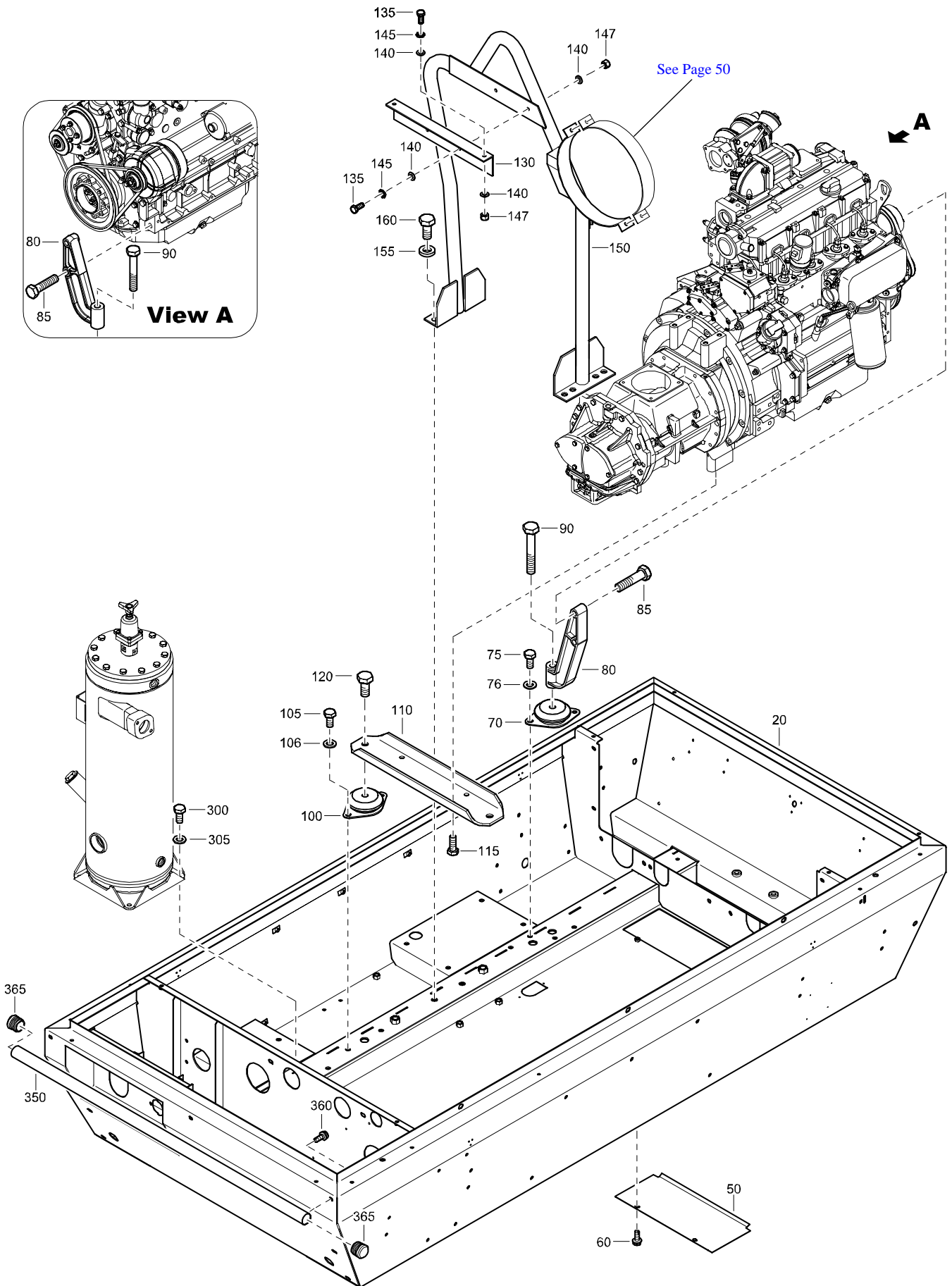



---

# STANDARD

## FRAME AND MOUNTS

---

REF	PART NUMBER	DESIGNATION	QTY	REF	PART NUMBER	DESIGNATION	QTY
20	1604 0250 83	FRAME ASSY (For details see page 68)	1				
50	1604 0252 01	PLATE	1				
60	1619 2766 00	HEX. HEAD SCREW	2				
70	1615 4945 03	ANTI VIBRATION PAD	2				
75	0147 1400 03	HEX. HEAD SCREW	4				
76	0301 2358 00	PLAIN WASHER	2				
80	1604 0256 01	SUPPORT	2				
85	0147 1482 03	HEX. HEAD SCREW	4				
90	0147 1487 03	HEX. HEAD SCREW	2				
100	1615 4945 03	ANTI VIBRATION PAD	2				
105	0147 1400 03	HEX. HEAD SCREW	4				
106	0301 2358 00	PLAIN WASHER	2				
110	1604 0255 01	SUPPORT	1				
115	0147 1401 15	HEX. HEAD SCREW	4				
120	0147 1476 03	HEX. HEAD SCREW	2				
130	1604 1457 00	BRACKET	1				
135	0147 1322 03	HEX. HEAD SCREW	4				
140	0301 2335 00	PLAIN WASHER	8				
145	0333 3227 00	LOCK WASHER	4				
147	0266 2110 00	HEXAGON NUT	4				
150	1604 0257 03	LIFTING EYE	1				
155	0302 1274 04	PLAIN WASHER	4				
160	0147 1476 03	HEX. HEAD SCREW	4				
300	0147 1400 03	HEX. HEAD SCREW	4				
305	0301 2358 00	PLAIN WASHER	4				
350	1604 0315 00	TUBE (FOR BUMPER)	1				
360	1619 2766 00	HEX. HEAD SCREW	3				
365	1615 8790 01	PLUG	2				

# STANDARD

## FUEL SYSTEM

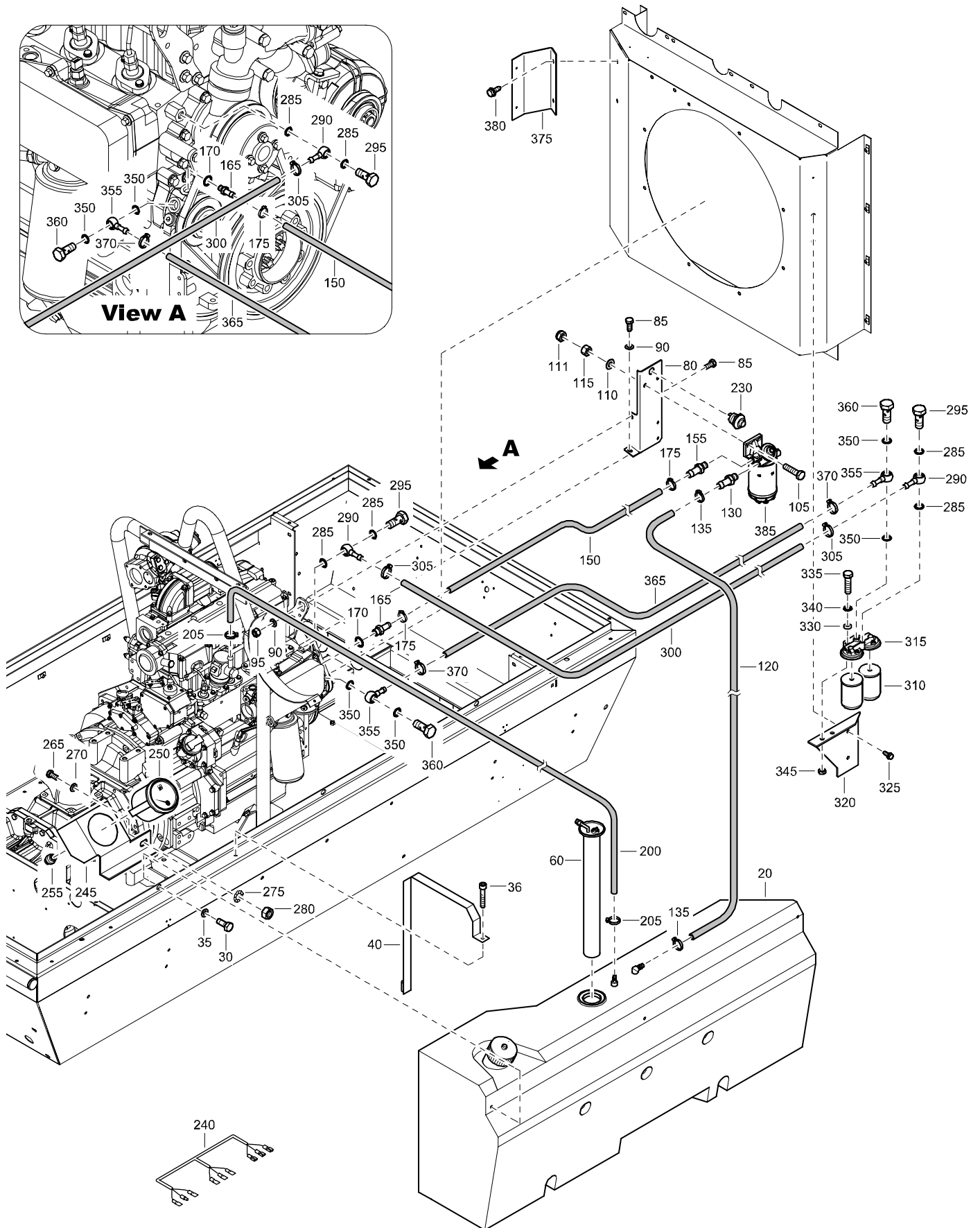
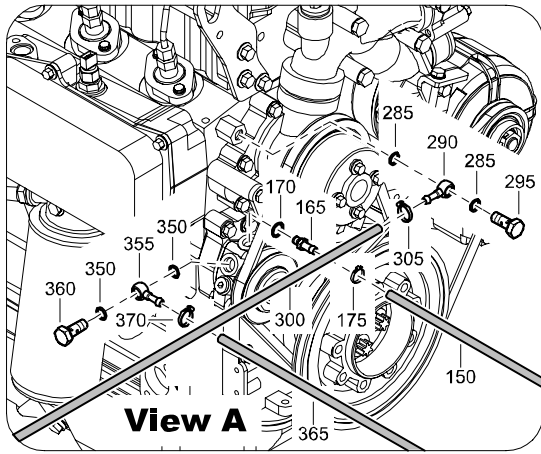

# STANDARD

## FUEL SYSTEM

REF	PART NUMBER	DESIGNATION	QTY	REF	PART NUMBER	DESIGNATION	QTY
20	1604 0261 85	FUELTANK ASSY (For details see page 69)	1				
30	0147 1322 03	HEX. HEAD SCREW	2				
35	0301 2335 00	PLAIN WASHER	2				
36	0211 1329 00	HEX SOCK. SCREW	1				
40	1604 0416 00	STRAP	1				
60	1615 5289 01	LEVEL GAUGE	1				
80	1604 0268 04	BRACKET	1				
85	0147 1322 03	HEX. HEAD SCREW	2				
90	0301 2335 00	PLAIN WASHER	2				
95	0266 2110 00	HEXAGON NUT	1				
105	0147 1364 03	HEX. HEAD SCREW	2				
110	0301 2344 00	PLAIN WASHER	2				
111	0291 1111 00	LOCKNUT	2				
115	0266 2111 00	HEXAGON NUT	2				
120	0072 8402 90	HOSE	AR				
130	1604 0265 01	HOSE NIPPLE	1				
135	0347 6104 00	HOSE CLAMP	2				
150	0072 8402 90	HOSE	AR				
155	1604 0265 01	HOSE NIPPLE	1				
165	1604 0269 01	HOSE NIPPLE	1				
170	0653 1100 00	FLAT GASKET	1				
175	0347 6104 00	HOSE CLAMP	2				
200	0071 8402 68	FUEL HOSE	AR				
205	0347 6104 00	HOSE CLAMP	2				
230	1089 9326 01	PUSH BUTTON	1				
240	1604 0296 00	WIRE HARNESS	1				
245	1604 0294 00	BRACKET	1				
250	1089 0631 03	FUEL GAUGE	1				
255	0277 1130 03	HEXAGON DOMED CAP NUT	1				
265	0147 1322 03	HEX. HEAD SCREW	1				
270	0301 2335 00	PLAIN WASHER	1				
275	0333 3227 00	LOCK WASHER	1				
280	0266 2110 00	HEXAGON NUT	1				
285	0653 1072 00	FLAT GASKET	4				
290	0571 0050 06	NIPPLE	2				
295	0627 4209 03	PRESSURE SCREW	2				
300	0071 8402 90	FUEL HOSE	AR				
305	0347 6105 00	HOSE CLAMP	2				
310	1604 1094 00	FILTER ELEMENT	2				
315	1604 1092 00	HOUSING	1				
320	1604 7207 00	BRACKET FUELFILTER	1				
325	1619 2766 00	HEX. HEAD SCREW	2				
330	0301 2344 00	PLAIN WASHER	4				
335	0147 1364 03	HEX. HEAD SCREW	2				
340	0333 3232 00	LOCK WASHER	2				
345	0266 2111 00	HEXAGON NUT	2				
350	0653 1072 00	FLAT GASKET	4				
355	0571 0050 06	NIPPLE	2				
360	0627 4209 03	PRESSURE SCREW	2				
365	0071 8402 90	FUEL HOSE	AR				
370	0347 6105 00	HOSE CLAMP	2				
375	1604 7209 00	SUPPORT	1				
380	1619 2766 00	HEX. HEAD SCREW	2				
385	1604 7543 00	FUELFILTER (WATERSEP.)	1				

# STANDARD

## ENGINE AND ACCESSORIES

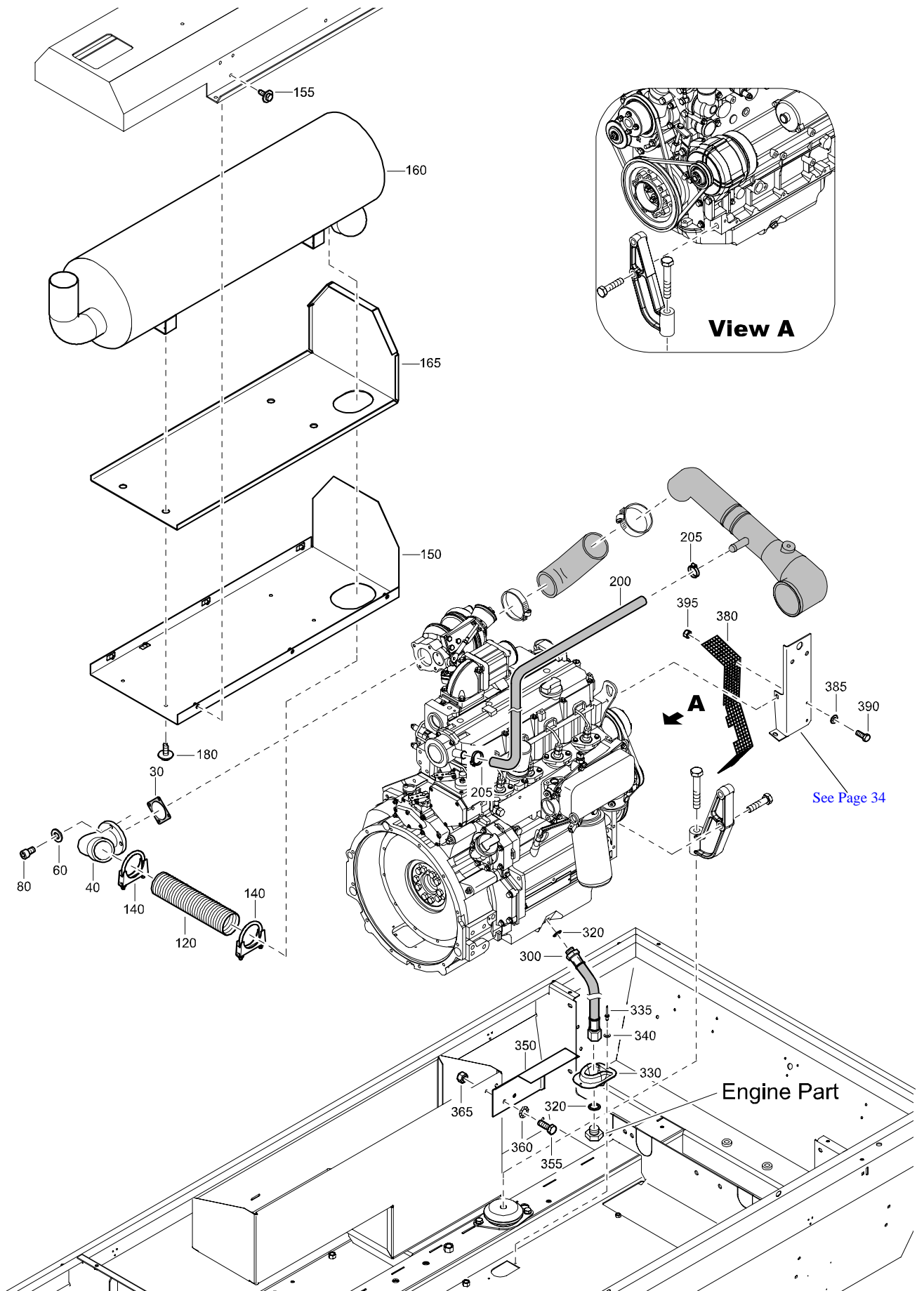

---

# STANDARD

## ENGINE AND ACCESSORIES

---

REF	PART NUMBER	DESIGNATION	QTY	REF	PART NUMBER	DESIGNATION	QTY
30	1604 1238 00	GASKET	1				
40	1604 0470 00	EXHAUST ELBOW	1				
60	0301 2335 00	PLAIN WASHER	4				
80	0211 1325 03	HEX SOCK. SCREW	4				
120	1604 0274 01	EXHAUST PIPE	1				
140	0346 2900 19	CLAMP	2				
150	1604 0436 01	PLATE	1				
155	1615 5664 00	HEX. HEAD SCREW	6				
160	1604 0433 01	SILENCER	1				
165	1604 0438 01	INSULATION	1				
180	1615 5664 00	HEX. HEAD SCREW	4				
200	0070 6002 27	PLASTIC TUBE	AR				
205	0347 6108 00	HOSE CLAMP	2				
300	1604 0276 00	HOSE ASSEMBLY	1				
320	0653 1115 00	FLAT GASKET	2				
330	1615 8785 00	PROTECTION	1				
335	0129 3174 01	BLIND RIVET	2				
340	0301 2318 00	PLAIN WASHER	2				
350	1604 1578 00	PROTECTION	1				
355	0147 1323 03	HEX. HEAD SCREW	2				
360	0333 3227 00	LOCK WASHER	2				
365	0266 2110 00	HEXAGON NUT	2				
380	1604 0379 00	PROTECTION	1				
385	0147 1246 03	HEX. HEAD SCREW	2				
390	0301 2321 00	PLAIN WASHER	2				
395	0266 2108 00	HEXAGON NUT	2				

# STANDARD

## GEARCASING AND MOUNTS

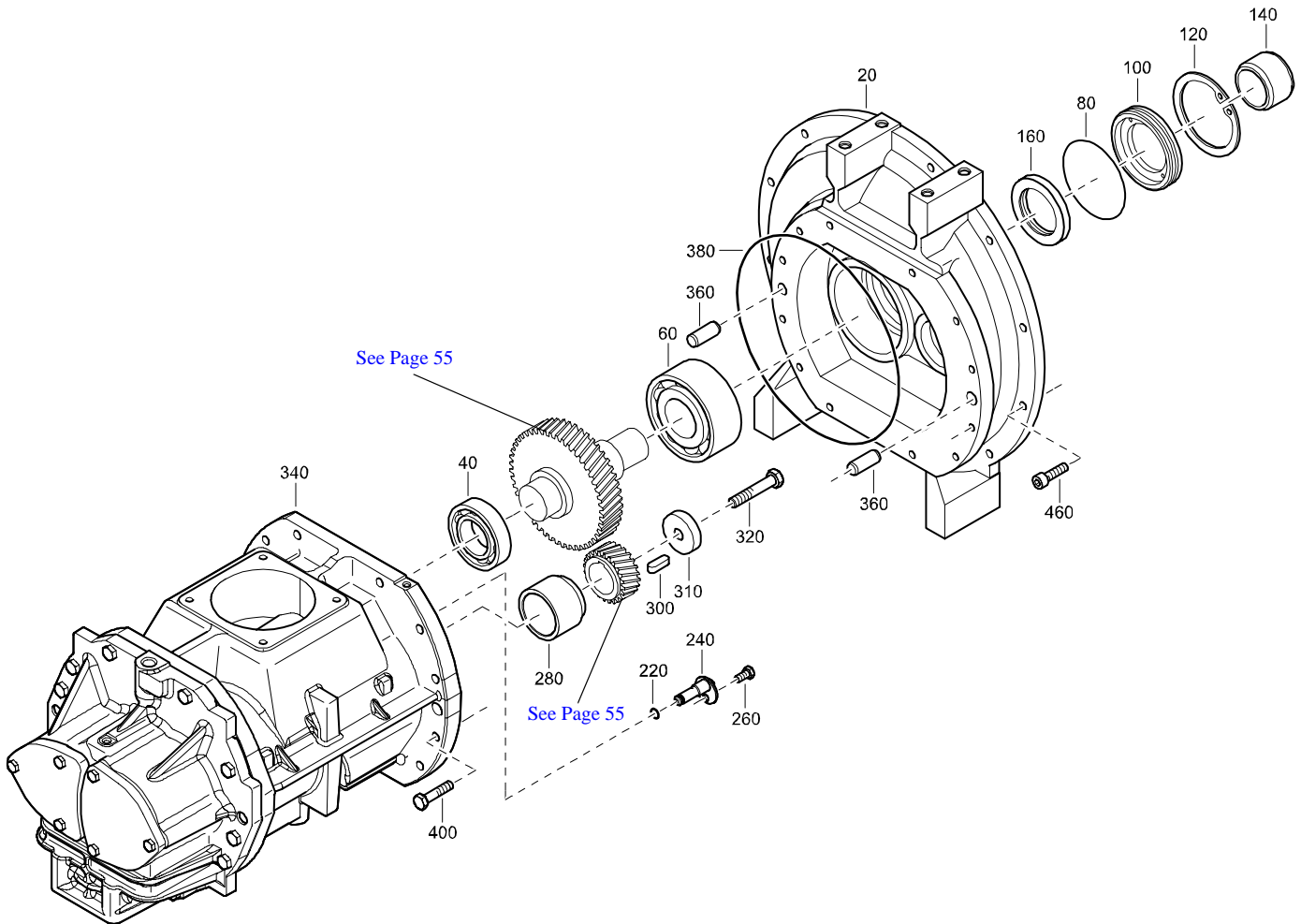

REF	PART NUMBER	DESIGNATION	QTY	REF	PART NUMBER	DESIGNATION	QTY
20	1604 0291 01	GEAR CASING	1	360	0101 1951 40	PARALLEL PIN	2
40	0502 1090 21	BALL BEARING	1	380	-	O-RING	1
60	0504 0200 13	BALL BEARING	1			(Part of service kit, see page 31)	
80	-	O-RING	1	400	0147 1365 03	HEX. HEAD SCREW	12
		(Part of service kit, see page 31)		460	0211 1964 15	HEX SOCK. SCREW	12
100	-	RETAINER	1				
		(Part of service kit, see page 31)					
120	0335 2169 00	CIRCLIP	1				
140	1202 6454 00	BUSHING	1				
160	-	LIP SEAL	1				
		(Part of service kit, see page 31)					
220	-	O-RING	1				
		(Part of service kit, see page 31)					
240	1622 5648 00	OIL NOZZLE	1				
260	3161 0388 00	HEXAGON BOLT	1				
280	1604 0272 00	BUSHING	1				
300	0337 7152 00	PARALLEL KEY	1				
310	1604 0287 00	WASHER	1				
320	0147 1408 15	HEX. HEAD SCREW	1				
340	1616 7281 90	SERVICE STAGE O.I.S. K-36	1				

# STANDARD

## COUPLING

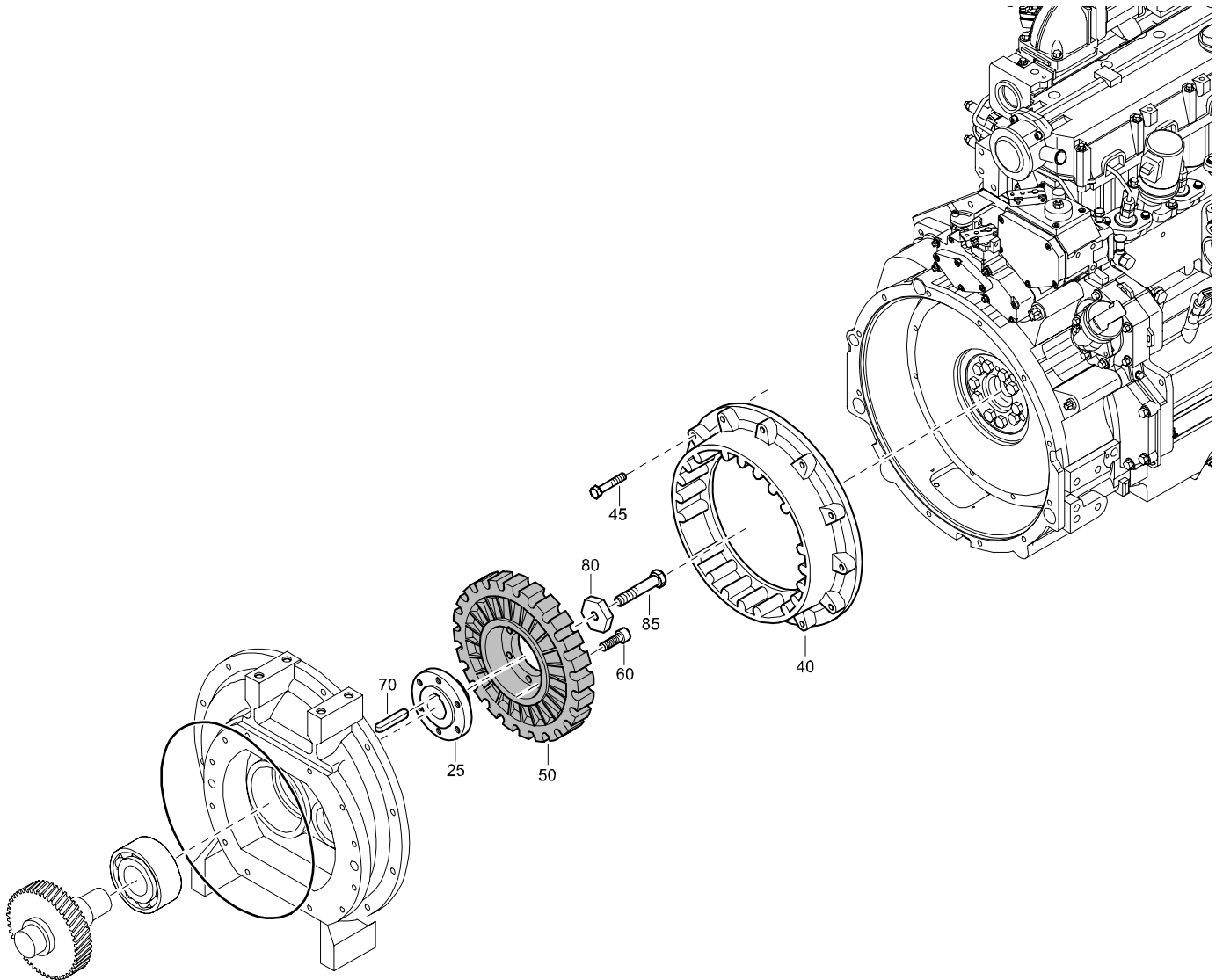

REF	PART NUMBER	DESIGNATION	QTY	REF	PART NUMBER	DESIGNATION	QTY
25	1604 0300 00	COUPLING HUB	1				
40	1604 0329 00	COUPLING RING	1				
45	0147 1329 03	HEX. HEAD SCREW	12				
50	1615 6825 00	COUPLING	1				
60	0211 1964 15	HEX SOCK. SCREW	6				
70	0337 7198 00	PARALLEL KEY	1				
80	1604 0287 00	WASHER	1				
85	0147 1408 15	HEX. HEAD SCREW	1				

# STANDARD

## REGULATING SYSTEM

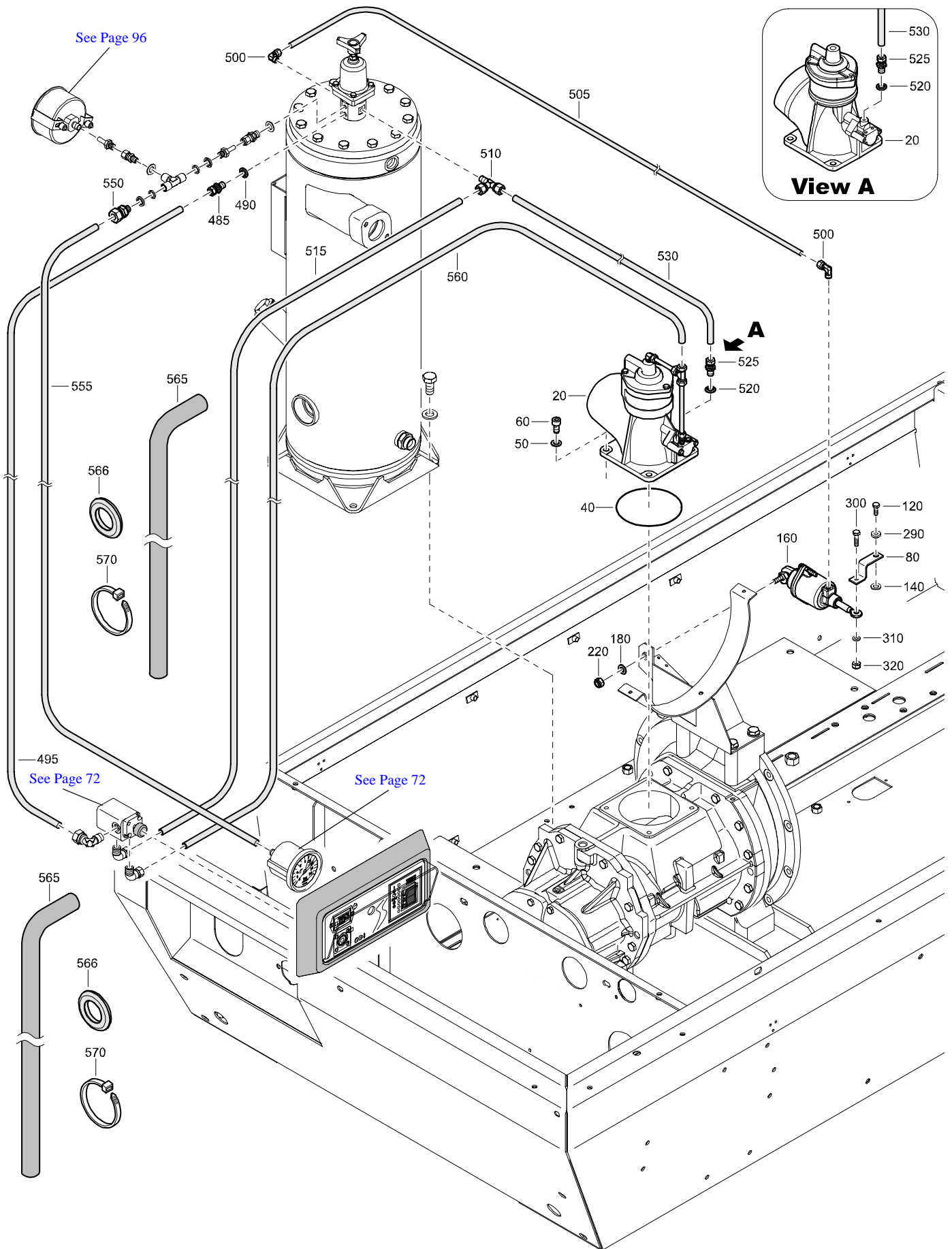



---

# STANDARD

## REGULATING SYSTEM

---

REF	PART NUMBER	DESIGNATION	QTY	REF	PART NUMBER	DESIGNATION	QTY
20	1604 0306 83	UNLOADING VALVE <a href="#">(For details see page 74)</a>	1				
40	-	O-RING <a href="#">(Part of service kit, see page 26, 31)</a>	1				
50	0301 2344 00	PLAIN WASHER	4				
60	0211 1360 03	HEX SOCK. SCREW	4				
80	1604 0325 01	LEVER	1				
120	0147 1246 03	HEX. HEAD SCREW	1				
140	0301 2335 00	PLAIN WASHER	1				
160	1604 0321 80	ACTUATING UNIT (ASSY) <a href="#">(For details see page 73)</a>	1				
180	0301 2335 00	PLAIN WASHER	1				
220	0291 1110 00	LOCKNUT	1				
290	1604 0327 00	BUSH	1				
300	0147 1247 03	HEX. HEAD SCREW	1				
310	0301 2321 00	PLAIN WASHER	2				
320	0291 1108 00	LOCKNUT	1				
485	0582 1200 06	STRAIGHT PIPE COUPLING	1				
490	0661 1014 00	SEALING WASHER	1				
495	0070 6002 04	PLASTIC TUBE	AR				
500	0582 1200 07	ELBOW PIPE COUPLING	2				
505	0070 6002 04	PLASTIC TUBE	AR				
510	0581 2000 23	TEE PIPE COUPLING	1				
515	0070 6002 05	PLASTIC TUBE	AR				
520	0661 1014 00	SEALING WASHER	1				
525	0582 1200 06	STRAIGHT PIPE COUPLING	1				
530	0070 6002 05	PLASTIC TUBE	AR				
550	1604 0341 00	PIPE COUPLING	1				
555	0070 6002 10	PLASTIC TUBE	AR				
560	0070 6002 05	PLASTIC TUBE	AR				
565	0395 1010 35	INSULATION HOSE	1				
566	1202 8335 00	RING	1				
570	1088 0830 10	CABLE CLAMP	6				

# STANDARD

## COOLER AND FAN

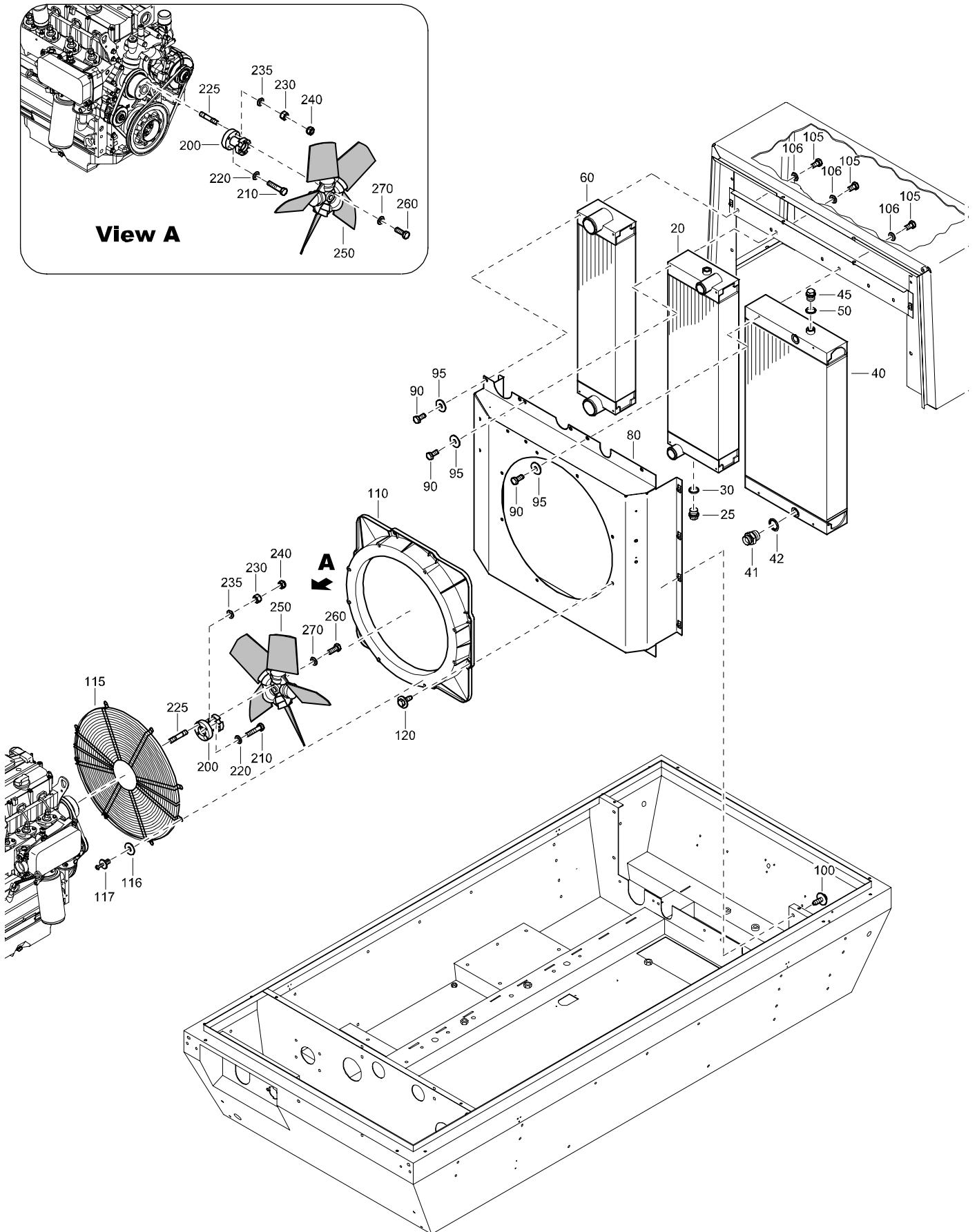

---

# STANDARD

## COOLER AND FAN

---

REF	PART NUMBER	DESIGNATION	QTY	REF	PART NUMBER	DESIGNATION	QTY
20	1604 9292 00	RADIATOR	1				
25	0686 3716 02	HEXAGON PLUG	1				
30	0661 1033 00	SEALING WASHER	1				
40	1604 9294 00	COOLER	1				
41	1619 5509 00	NIPPLE	2				
42	0661 1038 00	SEALING WASHER	2				
45	0686 3716 02	HEXAGON PLUG	1				
50	0661 1033 00	SEALING WASHER	1				
60	1604 9293 00	COOLER	1				
80	1626 0580 01	COWL	1				
90	0147 1321 03	HEX. HEAD SCREW	8				
95	0300 8019 00	PLAIN WASHER	8				
100	1615 5664 00	HEX. HEAD SCREW	5				
105	0147 1321 03	HEX. HEAD SCREW	6				
106	0300 8019 00	PLAIN WASHER	6				
110	1604 0337 02	FAN GUIDE	1				
115	1604 0339 01	FAN GUARD	2				
116	0300 8005 00	PLAIN WASHER	8				
117	1615 5556 00	RIVET	8				
120	1615 5664 00	HEX. HEAD SCREW	8				
200	1604 0331 00	FAN ADAPTOR	1				
210	0147 1327 03	HEX. HEAD SCREW	2				
220	0301 2335 00	PLAIN WASHER	2				
225	0246 1202 02	STUD	2				
230	0266 2110 00	HEXAGON NUT	2				
235	0301 2335 00	PLAIN WASHER	2				
240	0291 1110 00	LOCKNUT	2				
250	1604 0338 00	FAN	1				
260	0147 1323 03	HEX. HEAD SCREW	4				
270	0301 2335 00	PLAIN WASHER	4				

# STANDARD

## ENGINE COOLING

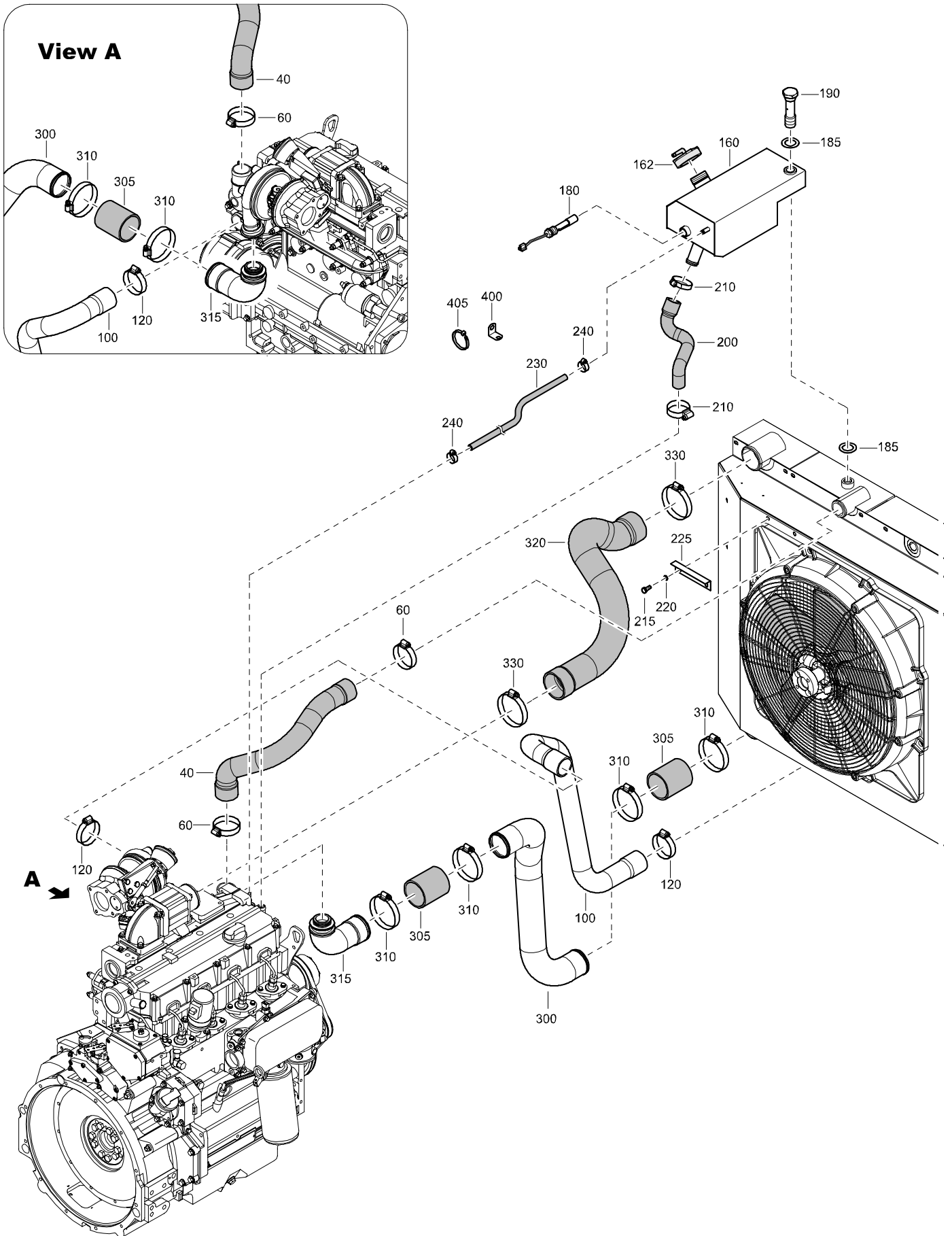

---

# STANDARD

## ENGINE COOLING

---

REF	PART NUMBER	DESIGNATION	QTY	REF	PART NUMBER	DESIGNATION	QTY
40	1626 0637 00	HOSE	1				
60	0347 6100 19	HOSE CLAMP	2				
100	1604 0514 01	PIPE	1				
120	0347 6100 19	HOSE CLAMP	2				
160	1604 0510 01	TOPTANK	1				
162	1615 6650 00	RADIATOR CAP	1				
180	1089 0568 12	LEVEL SWITCH	1				
185	0653 1133 00	FLAT GASKET	2				
190	1604 0511 00	BANJO BOLT	1				
200	1626 0638 00	HOSE	1				
210	0347 6110 00	HOSE CLAMP	2				
215	0147 1322 03	HEX. HEAD SCREW	2				
220	0333 3227 00	LOCK WASHER	2				
225	1604 4483 00	BRACKET	1				
230	0071 8402 68	FUEL HOSE	AR				
240	0347 6103 00	HOSE CLAMP	2				
300	1626 0847 00	PIPE	1				
305	1626 0831 00	HOSE	2				
310	0347 6100 21	HOSE CLAMP	4				
315	1626 0857 00	ELBOW	1				
320	1626 0620 00	HOSE	1				
330	0347 6100 21	HOSE CLAMP	2				
400	1613 0808 02	BRACKET	1				
405	1088 1301 06	CABLE CLIP	1				

# STANDARD

## OIL SYSTEM

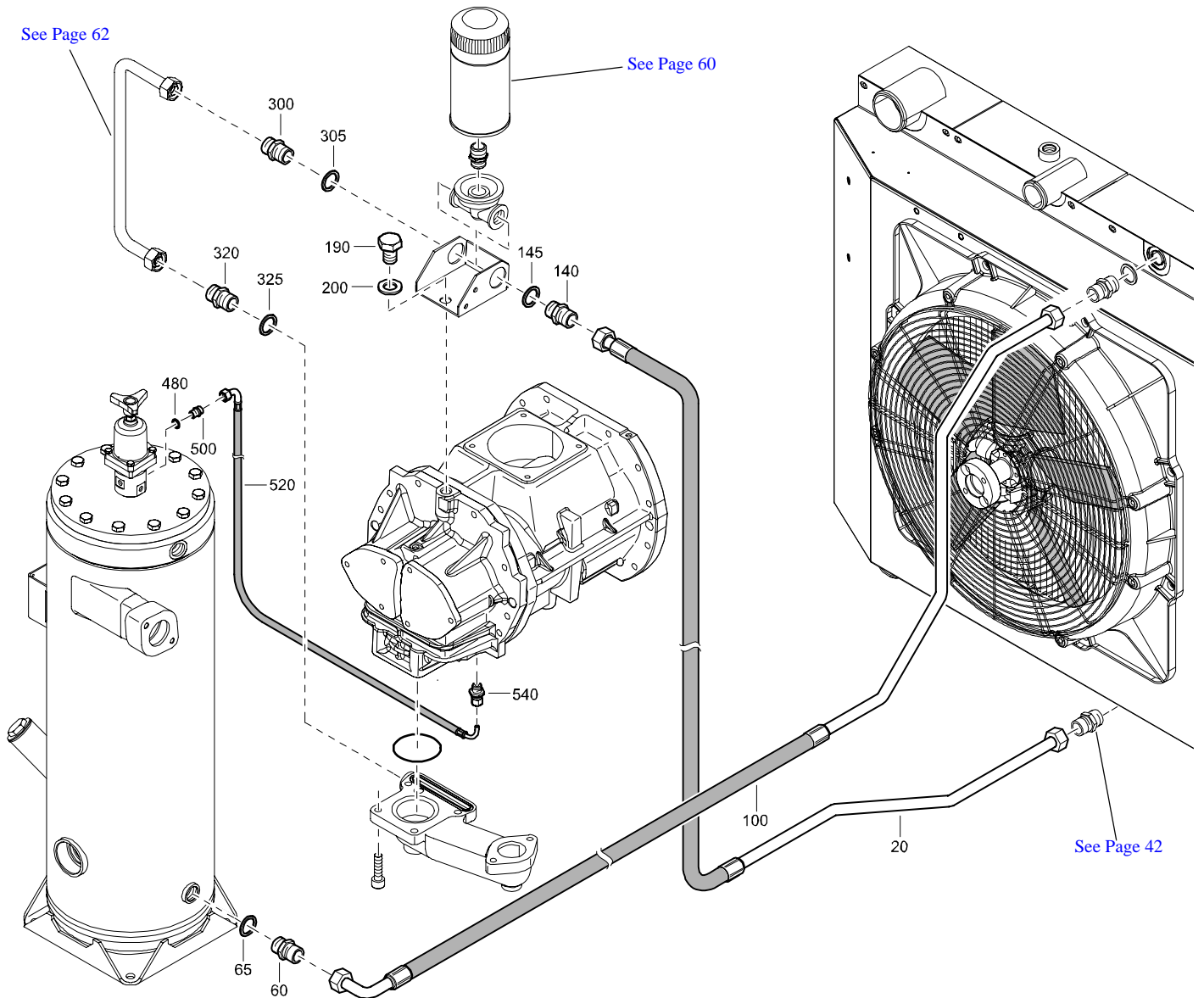

REF	PART NUMBER	DESIGNATION	QTY	REF	PART NUMBER	DESIGNATION	QTY
20	1604 0371 01	HOSE ASSEMBLY	1				
60	1619 5509 00	NIPPLE	1				
65	0661 1038 00	SEALING WASHER	1				
100	1604 0375 03	HOSE ASSEMBLY	1				
140	1619 5509 00	NIPPLE	1				
145	0661 1038 00	SEALING WASHER	1				
190	0147 1474 03	HEX. HEAD SCREW	1				
200	0301 2378 00	PLAIN WASHER	1				
300	1619 5509 00	NIPPLE	1				
305	0661 1038 00	SEALING WASHER	1				
320	1619 5509 00	NIPPLE	1				
325	0661 1038 00	SEALING WASHER	1				
480	0653 1043 00	FLAT GASKET	1				
500	1079 5840 01	HEXAGON NIPPLE	1				
520	0575 0461 40	HOSE ASSEMBLY	1				
540	0581 0000 52	STRAIGHT PIPE COUPLING	1				

# STANDARD

## AIR OUTLET

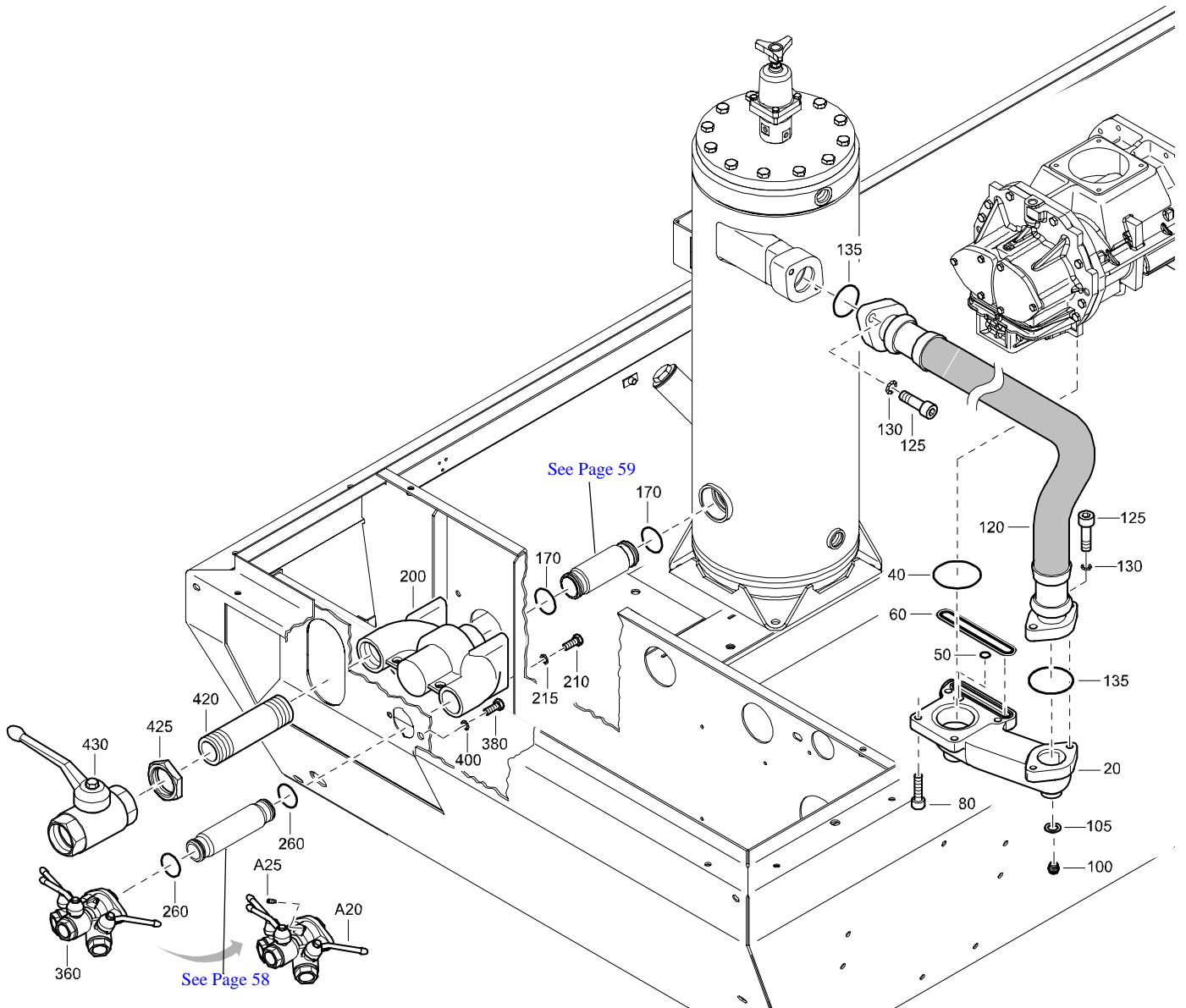

REF	PART NUMBER	DESIGNATION	QTY	REF	PART NUMBER	DESIGNATION	QTY
20	1604 6945 04	MANIFOLD	1				
40	-	O-RING (Part of service kit, see page 31)	1	260	-	O-RING (Part of service kit, see page 31)	2
50	0663 7119 00	O-RING	1	360	1615 9474 81	BALL VALVE ASSY	1
60	-	O-RING (Part of service kit, see page 31)	1	•A20	1615 9474 01	VALVE HOUSING	1
80	0211 1964 15	HEX SOCK. SCREW	4	•A25	0194 1169 00	SET SCREW	1
100	0686 3716 01	HEXAGON PLUG	1	380	0147 1323 03	HEX. HEAD SCREW	2
105	-	FLAT GASKET (Part of service kit, see page 31)	1	400	0333 3227 00	LOCK WASHER	2
120	1604 0358 00	HOSE ASSEMBLY	1	420	1604 0404 00	PIPE	1
125	0211 1964 10	HEX SOCK. SCREW	4	425	0623 2100 12	BACKNUT	1
130	0333 3237 00	LOCK WASHER	4	430	0852 0010 30	BALL VALVE	1
135	-	O-RING (Part of service kit, see page 31)	2				
170	-	O-RING (Part of service kit, see page 31)	2				
200	1604 0406 80	MINIMUM PRESSURE VALVE	1				
210	0147 1323 03	HEX. HEAD SCREW	4				
215	0333 3227 00	LOCK WASHER	4				

# STANDARD

## SAFETY AND CONTROL

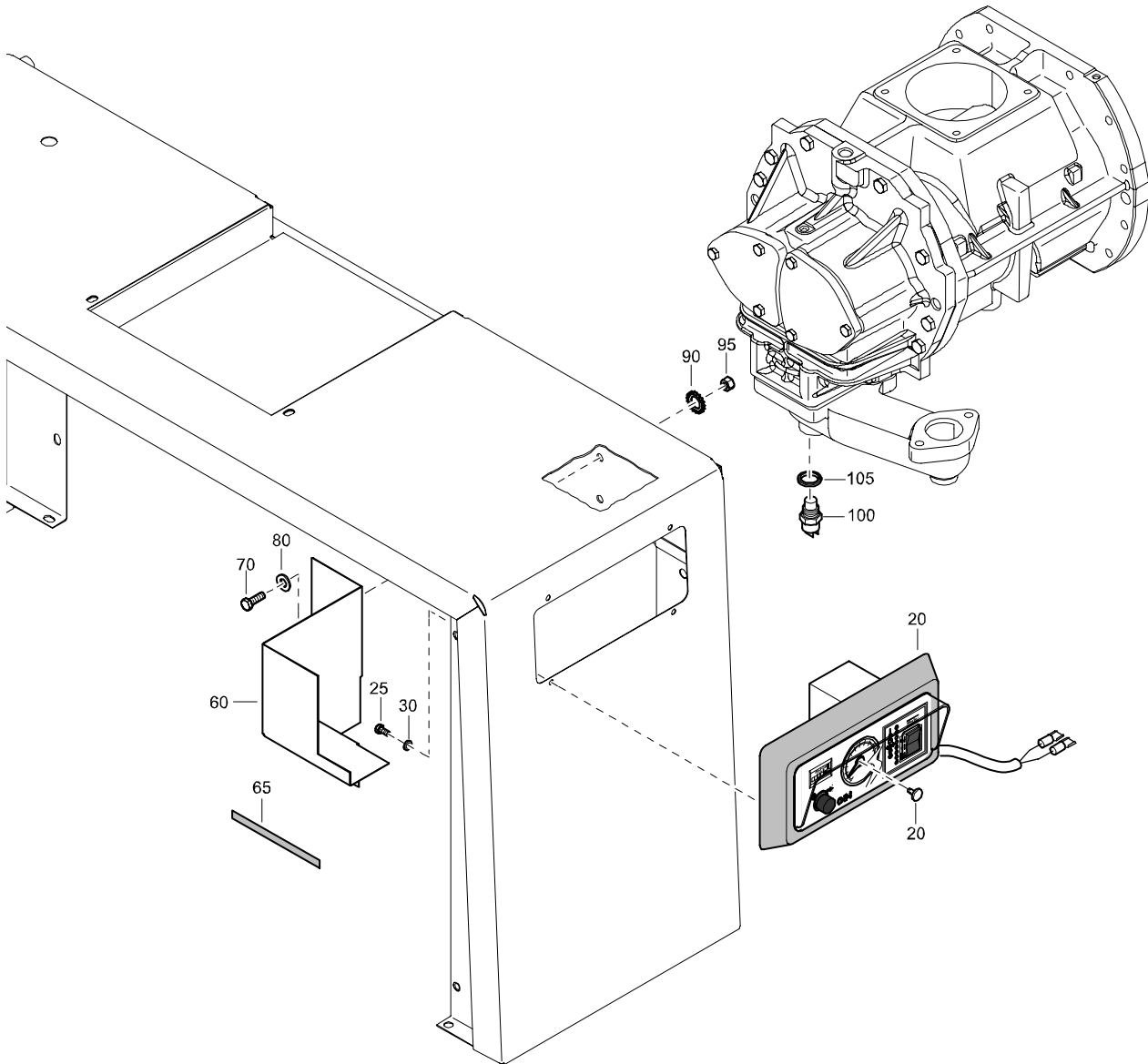

REF	PART NUMBER	DESIGNATION	QTY	REF	PART NUMBER	DESIGNATION	QTY
20	1604 0471 85	INSTRUM PANEL ASSY (For details see page 72)	1				
25	0147 1244 03	HEX. HEAD SCREW	4				
30	0301 2321 00	PLAIN WASHER	4				
50	1619 6201 00	PLUG	1				
60	1604 1456 02	BRACKET	1				
65	1503 1056 00	SEAL	AR				
70	0147 1323 03	HEX. HEAD SCREW	2				
85	0301 2335 00	PLAIN WASHER	2				
90	0333 3227 00	LOCK WASHER	2				
95	0266 2110 00	HEXAGON NUT	2				
100	1615 7831 02	TEMPERATURE SWITCH	1				
105	0661 1033 00	SEALING WASHER	1				



# STANDARD

## MARKINGS

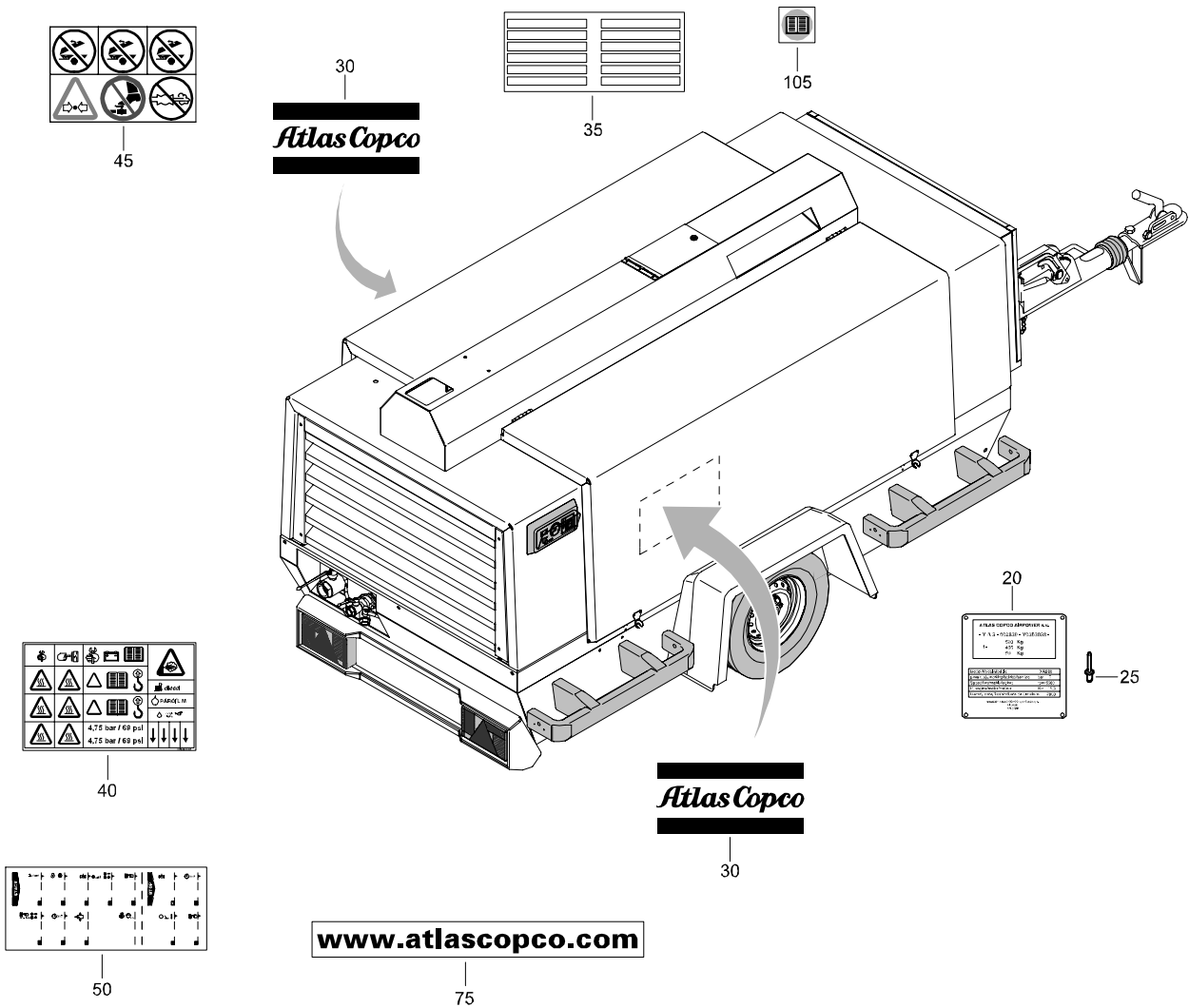

REF	PART NUMBER	DESIGNATION	QTY	REF	PART NUMBER	DESIGNATION	QTY
20	-	DATA PLATE (Not available separately)	1				
25	0129 3270 34	BLIND RIVET	4				
30	0690 1150 00	HOUSE MARK	2				
35	1079 9905 51	INSTRUCTION LABEL	1				
40	1079 9910 02	INFORMATION LABEL	1				
45	1079 9902 29	WARNING LABEL	1				
50	1079 9908 34	INSTRUCTION LABEL	1				
75	1079 9921 03	INFORMATION LABEL	1				
105	1079 9922 07	INFORMATION LABEL	1				

# STANDARD

## AIR INLET

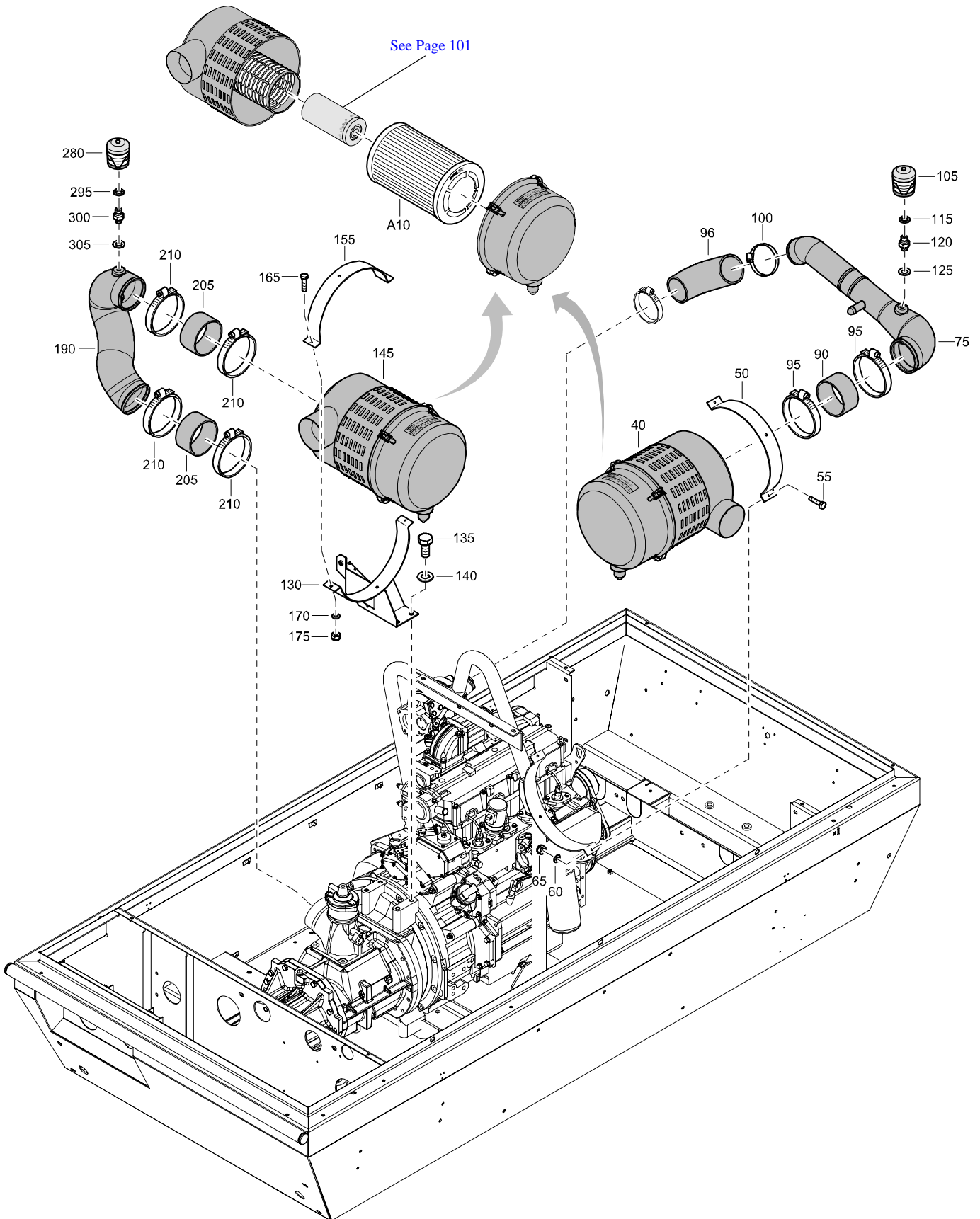

---

# STANDARD

## AIR INLET

---

REF	PART NUMBER	DESIGNATION	QTY	REF	PART NUMBER	DESIGNATION	QTY
40	1615 9388 01	AIRFILTER	1				
•A10	1613 8004 00	ELEMENT	1				
50	1615 9439 00	CLAMP	1				
55	0147 1249 03	HEX. HEAD SCREW	2				
60	0301 2321 00	PLAIN WASHER	2				
65	0291 1108 00	LOCKNUT	2				
75	1604 0413 02	PIPE	1				
90	1615 9438 00	HOSE	1				
95	0347 6119 00	HOSE CLAMP	2				
96	1604 0495 00	HOSE	1				
100	0347 6131 00	HOSE CLAMP	1				
105	1613 7912 01	INDICATOR	1				
115	0661 1014 00	SEALING WASHER	1				
120	1612 2152 00	NIPPLE	1				
125	0653 1046 00	FLAT GASKET	1				
130	1604 0409 03	SUPPORT	1				
135	0147 1398 03	HEX. HEAD SCREW	4				
140	0301 2358 00	PLAIN WASHER	4				
145	1615 9388 01	AIRFILTER	1				
•A10	1613 8004 00	ELEMENT	1				
155	1615 9439 00	CLAMP	1				
165	0147 1249 03	HEX. HEAD SCREW	2				
170	0301 2321 00	PLAIN WASHER	2				
175	0291 1108 00	LOCKNUT	2				
190	1604 0411 01	AIRDUCT	1				
205	1615 9438 00	HOSE	2				
210	0347 6119 00	HOSE CLAMP	4				
280	1613 7912 01	INDICATOR	1				
295	0661 1014 00	SEALING WASHER	1				
300	1612 2152 00	NIPPLE	1				
305	0653 1046 00	FLAT GASKET	1				

# STANDARD

## BODYWORK AND MOUNTS

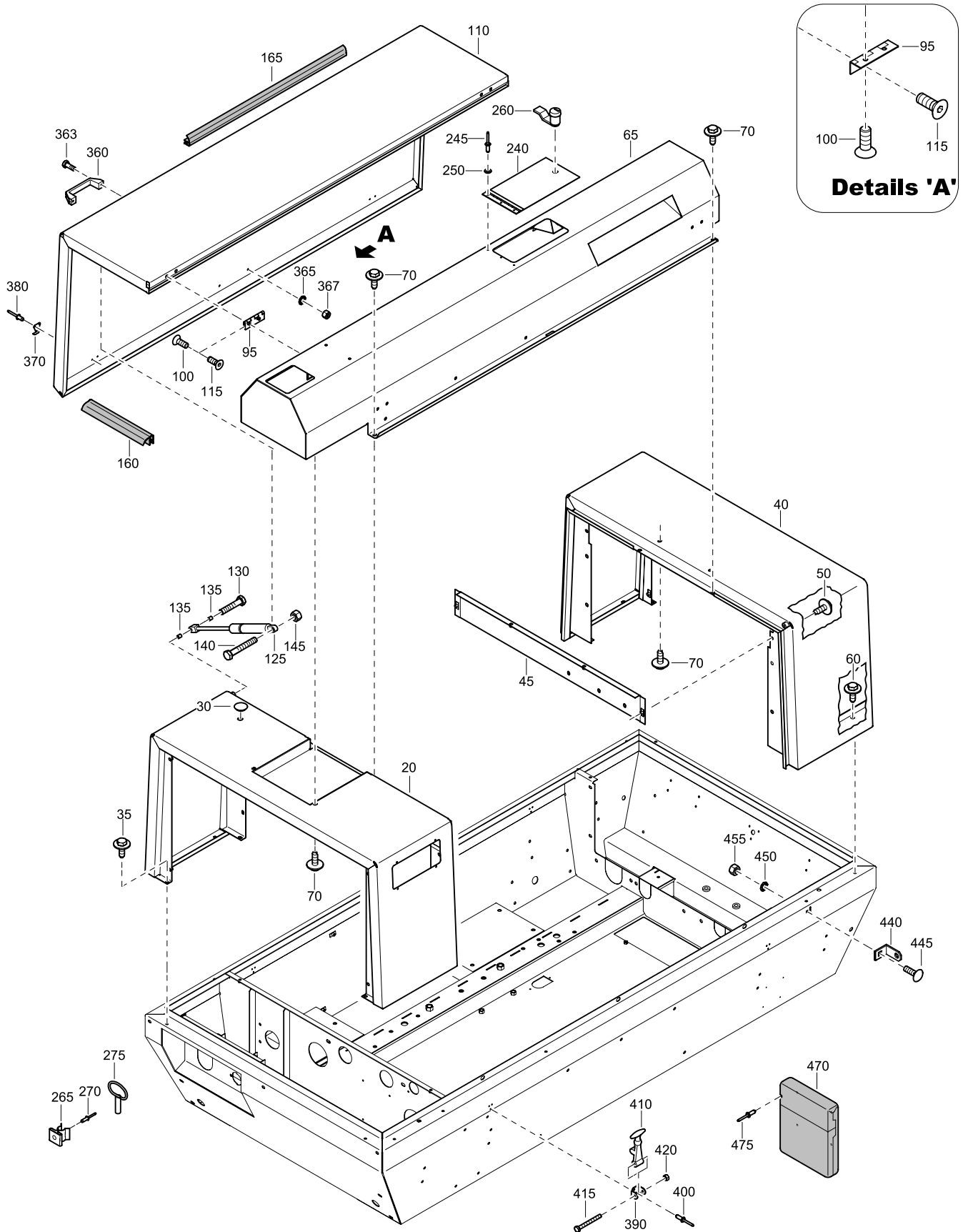

---

# STANDARD

## BODYWORK AND MOUNTS

---

REF	PART NUMBER	DESIGNATION	QTY	REF	PART NUMBER	DESIGNATION	QTY
20	1604 0420 08	PANEL	1				
35	1615 5664 00	HEX. HEAD SCREW	8				
40	1604 0422 05	FRONT PANEL	1				
45	1604 0846 00	PLATE	1				
50	1615 5664 00	HEX. HEAD SCREW	2				
60	1615 5664 00	HEX. HEAD SCREW	8				
65	1604 0434 02	DUCT	1				
70	1615 5664 00	HEX. HEAD SCREW	8				
95	1615 7712 00	HINGE	4				
100	0216 1324 03	HEX SOCK. SCREW	8				
110	1604 0423 02	DOOR (LH & RH)	2				
115	0216 1324 03	HEX SOCK. SCREW	8				
125	1604 0435 00	GASSPRING	2				
130	0147 1328 03	HEX. HEAD SCREW	2				
135	0324 1000 16	DISTANCE SLEEVE	4				
140	0147 1331 03	HEX. HEAD SCREW	2				
145	0291 1110 00	LOCKNUT	2				
160	1619 2665 00	SEAL	AR				
165	1604 4318 00	SEAL	AR				
240	1604 0429 02	COVER	1				
245	0129 3174 01	BLIND RIVET	3				
250	0301 2318 00	PLAIN WASHER	3				
260	1615 5692 00	LOCK	1				
265	1612 1574 00	SPRING CLIP	1				
270	0129 3115 00	BLIND RIVET	1				
275	1089 9068 01	KEY	1				
360	1202 8673 00	HANDGRIP	2				
363	0147 1246 03	HEX. HEAD SCREW	4				
365	0333 3220 00	LOCK WASHER	4				
367	0266 2108 00	HEXAGON NUT	4				
370	1615 8605 00	STIRRUP	4				
380	0129 3174 01	BLIND RIVET	8				
390	1619 2980 01	BASE PLATE	4				
400	0129 3174 01	BLIND RIVET	12				
410	1619 2978 01	CATCH	4				
415	0147 1214 03	HEX. HEAD SCREW	4				
420	0291 1107 00	LOCKNUT	4				
440	1615 8604 00	BRACKET	2				
445	0226 9915 17	SQ. NECK BOLT	2				
450	0333 3227 00	LOCK WASHER	2				
455	0266 2110 00	HEXAGON NUT	2				
470	1604 2206 00	HOLDER (DOCUMENT)	1				
475	0129 3174 01	BLIND RIVET	2				
480	0686 9252 77	PROTECTION PLUG	1				

# STANDARD

## ELECTRICAL SYSTEM

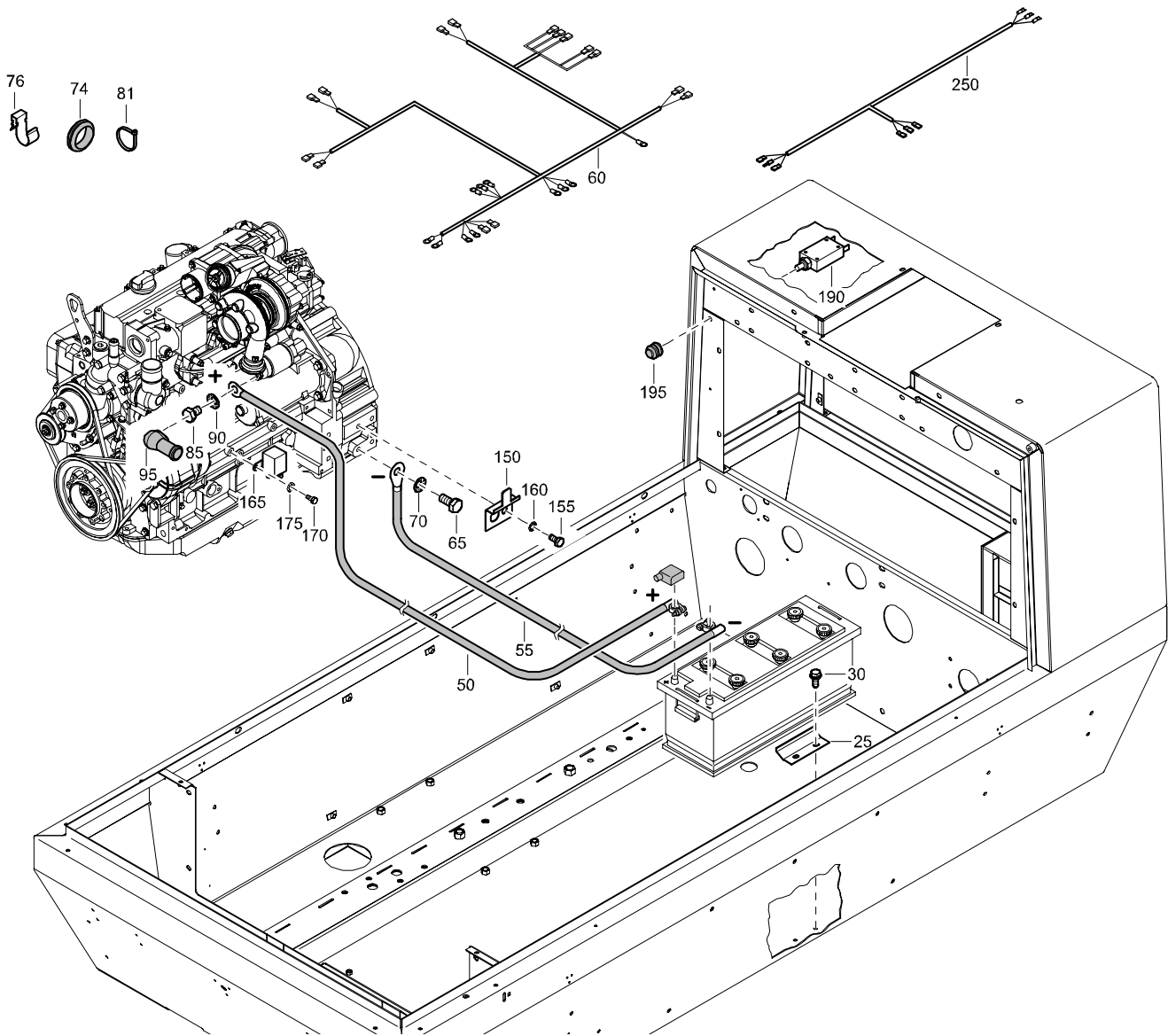

REF	PART NUMBER	DESIGNATION	QTY	REF	PART NUMBER	DESIGNATION	QTY
25	1202 9011 00	CLAMP	1	195	1089 9206 59	PROTECTION CAP	1
30	1619 2766 00	BOLT	2				
50	1604 0469 00	BATTERY CABLE	1				
55	2250 2382 46	BATTERY CABLE	1				
60	1604 0480 03	WIRE HARNESS	1				
65	0147 1398 03	HEX. HEAD SCREW	1				
70	1088 0019 03	CONTACT WASHER	1				
74	1088 0801 40	GROMMET	1				
76	1088 0830 10	CABLE CLAMP	4				
81	1088 1301 01	CABLE STRIP	5				
85	0147 1397 03	HEX. HEAD SCREW	1				
90	1088 0019 03	CONTACT WASHER	1				
95	1619 3729 00	PROTECT.CAP	1				
150	1615 9849 00	SUPPORT	1				
155	0147 1320 03	HEX. HEAD SCREW	1				
160	0333 3227 00	LOCK WASHER	1				
165	1089 0585 01	RELAY	1				
170	0147 1243 03	HEX. HEAD SCREW	2				
175	0333 3220 00	LOCK WASHER	2				
190	1089 9206 31	CIRCUIT BREAKER	1				

# STANDARD

## GEARSET I=2,429

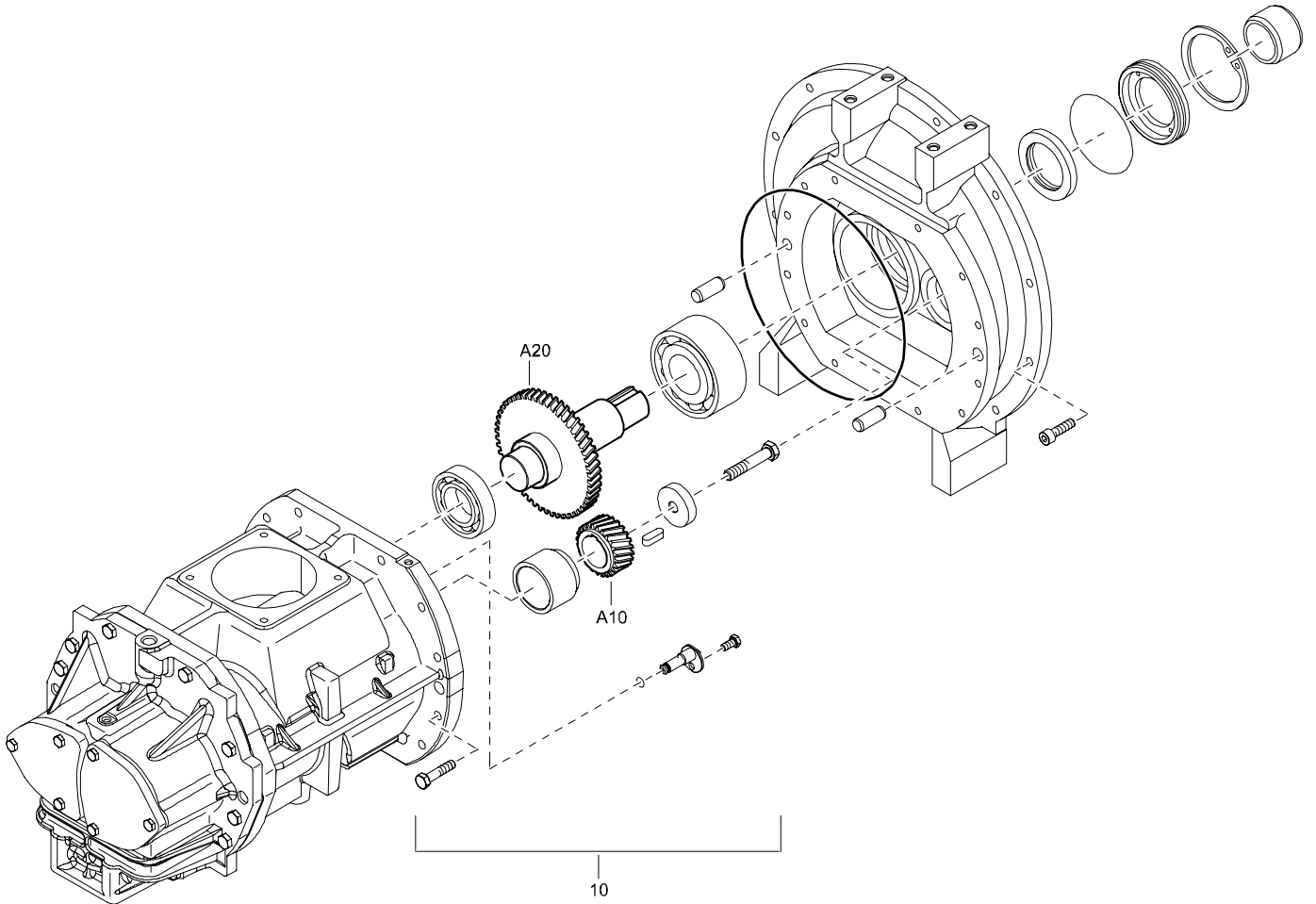

REF	PART NUMBER	DESIGNATION	QTY	REF	PART NUMBER	DESIGNATION	QTY
10	1604 7386 81	GEARSET I=2.429	1				
•A10	1604 0330 00	GEAR WHEEL	1				
•A20	1604 7386 00	DRIVE	1				

---

# STANDARD

## VALVES ON VESSEL FOR EC

---

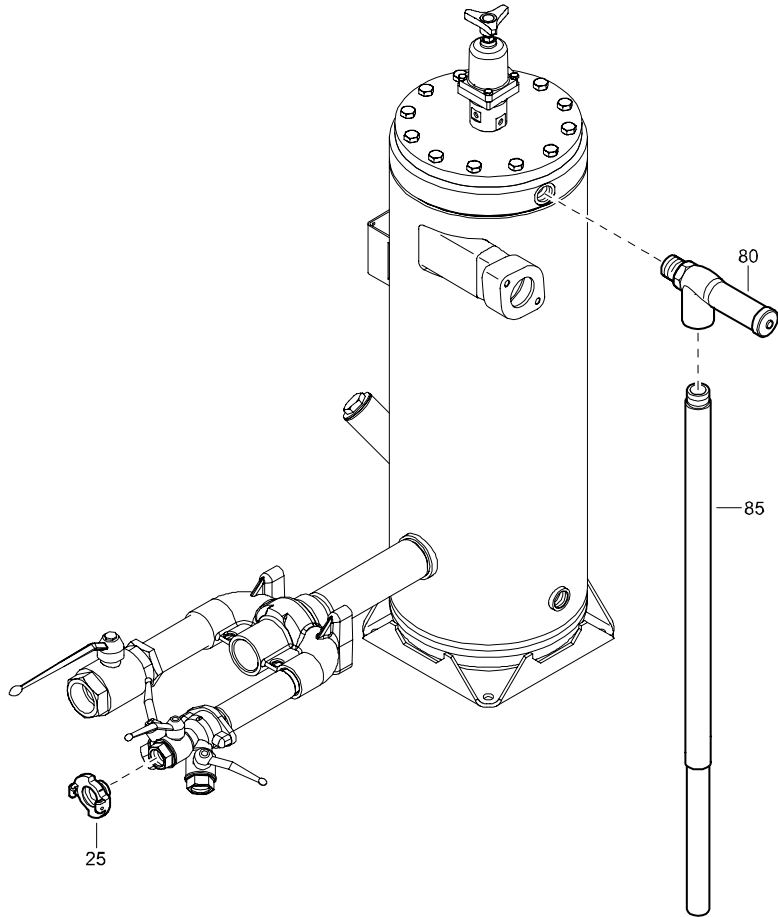

REF	PART NUMBER	DESIGNATION	QTY	REF	PART NUMBER	DESIGNATION	QTY
25	9000 0302 00	PIPE COUPL.	3				
80	0832 1001 17	SAFETY VALVE	1				
85	1604 4846 00	PIPE	1				



# STANDARD

## VALVES ON VESSEL FOR ASME

**CALIFORNIA Proposition 65 Warning**  
Diesel engine exhaust and some of its constituents are known to the State of California to cause cancer, birth defects, and other reproductive harm.

30

**Compressor noise emission control information**  
This compressor conforms to U.S. E.P.A. regulations for noise emissions applicable to portable air compressors.  
The information on this label complies with the requirements of the Federal Noise Control Act of 1972.  
Do not use or modify this compressor, either now or in the future, for any purpose other than that for which it was designed. Do not use or modify this compressor in any way that would void the warranty or create a safety hazard.  
Do not use or modify this compressor in any way that would void the warranty or create a safety hazard.

40

**Tampering with noise control system prohibited**  
Federal law prohibits the following acts or the causing thereof:  
1. The removal or tampering with any noise control system component or the causing thereof.  
2. The use of any component or part of any noise control system in a manner not intended by the manufacturer.  
3. The use of any component or part of any noise control system in a manner that would void the warranty or create a safety hazard.  
4. The use of any component or part of any noise control system in a manner that would void the warranty or create a safety hazard.

35

See Page 47

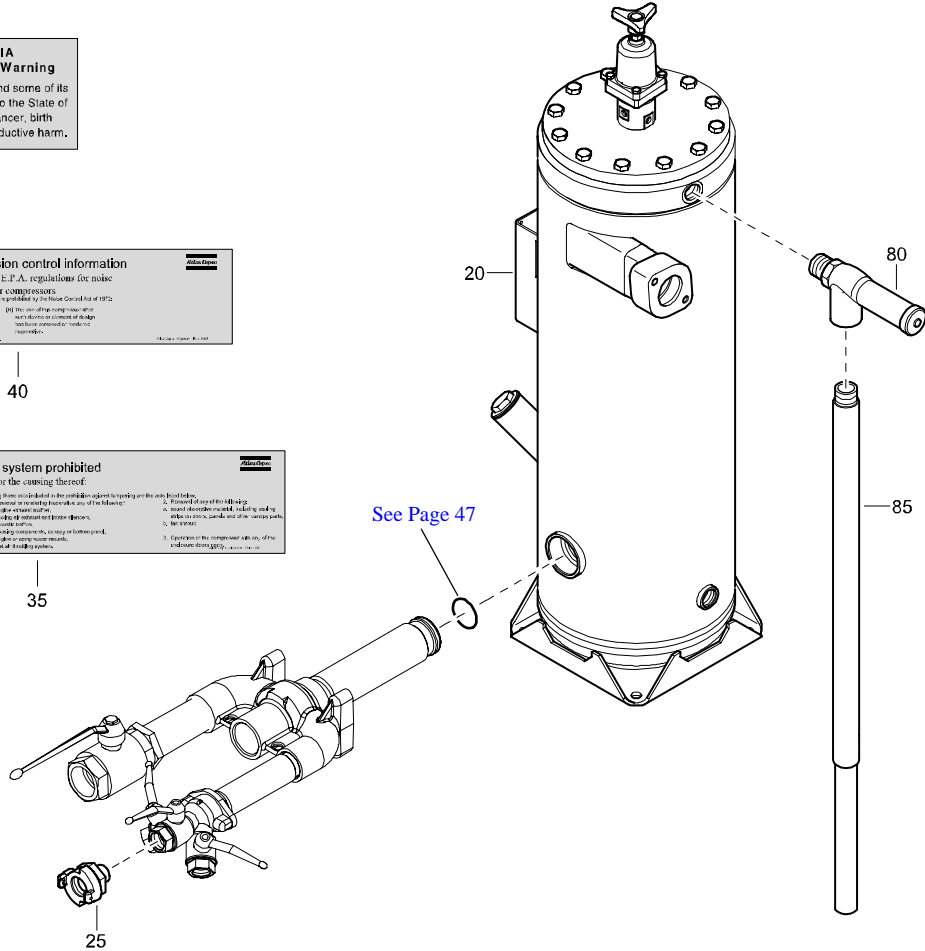

REF	PART NUMBER	DESIGNATION	QTY	REF	PART NUMBER	DESIGNATION	QTY
20	1604 0382 91	OIL SEPARATOR (For details see page 71)	1				
25	1310 1365 00	PIPE COUPLING	3				
30	1079 9902 47	WARNING LABEL	1				
35	1613 3385 00	DECAL	1				
40	1613 3384 00	DECAL	2				
80	0832 1001 18	SAFETY VALVE	1				
85	1604 4846 00	PIPE	1				

---

# STANDARD

## AIR OUTLET PIPE FOR COMPRESSOR WITHOUT LUBRICATOR

---

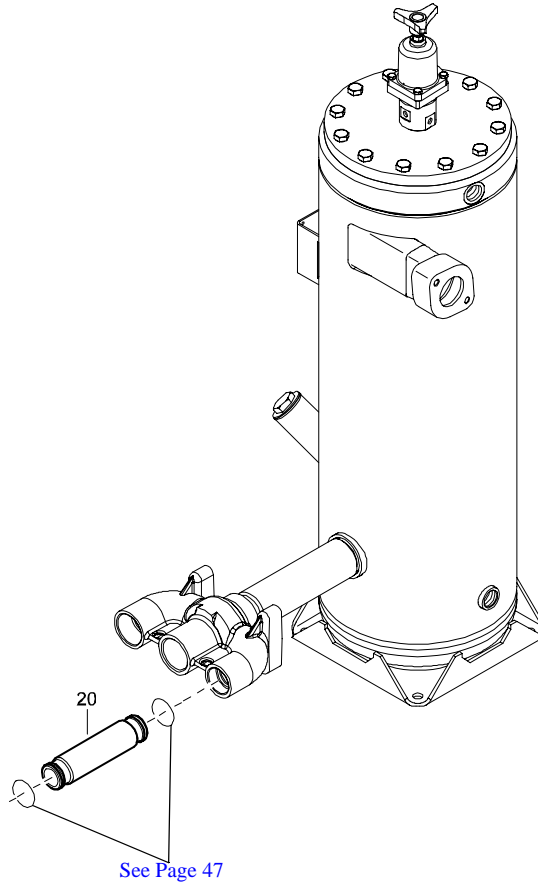

REF	PART NUMBER	DESIGNATION	QTY	REF	PART NUMBER	DESIGNATION	QTY
20	1604 0405 00	PIPE	1				

---

# STANDARD

## AIR OUTLET PIPE FOR COMPRESSOR WITHOUT AFTERCOOLER & COLD WEATHER EQUIPMENT

---

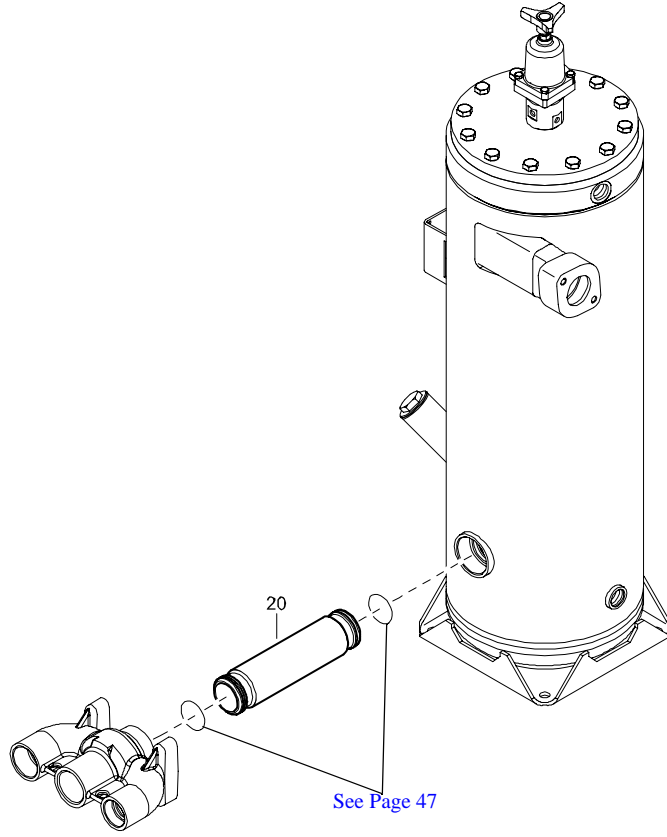

REF	PART NUMBER	DESIGNATION	QTY	REF	PART NUMBER	DESIGNATION	QTY
20	1604 0403 00	PIPE	1				

---

# STANDARD

## OILFILTER

---

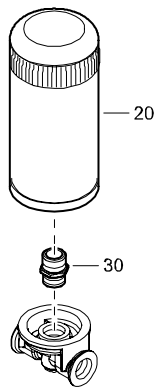

REF	PART NUMBER	DESIGNATION	QTY	REF	PART NUMBER	DESIGNATION	QTY
20	1613 6105 00	OIL FILTER	1				
30	1619 3770 00	NIPPLE	1				

# STANDARD

## BAFFLES WITH SILENCING SET

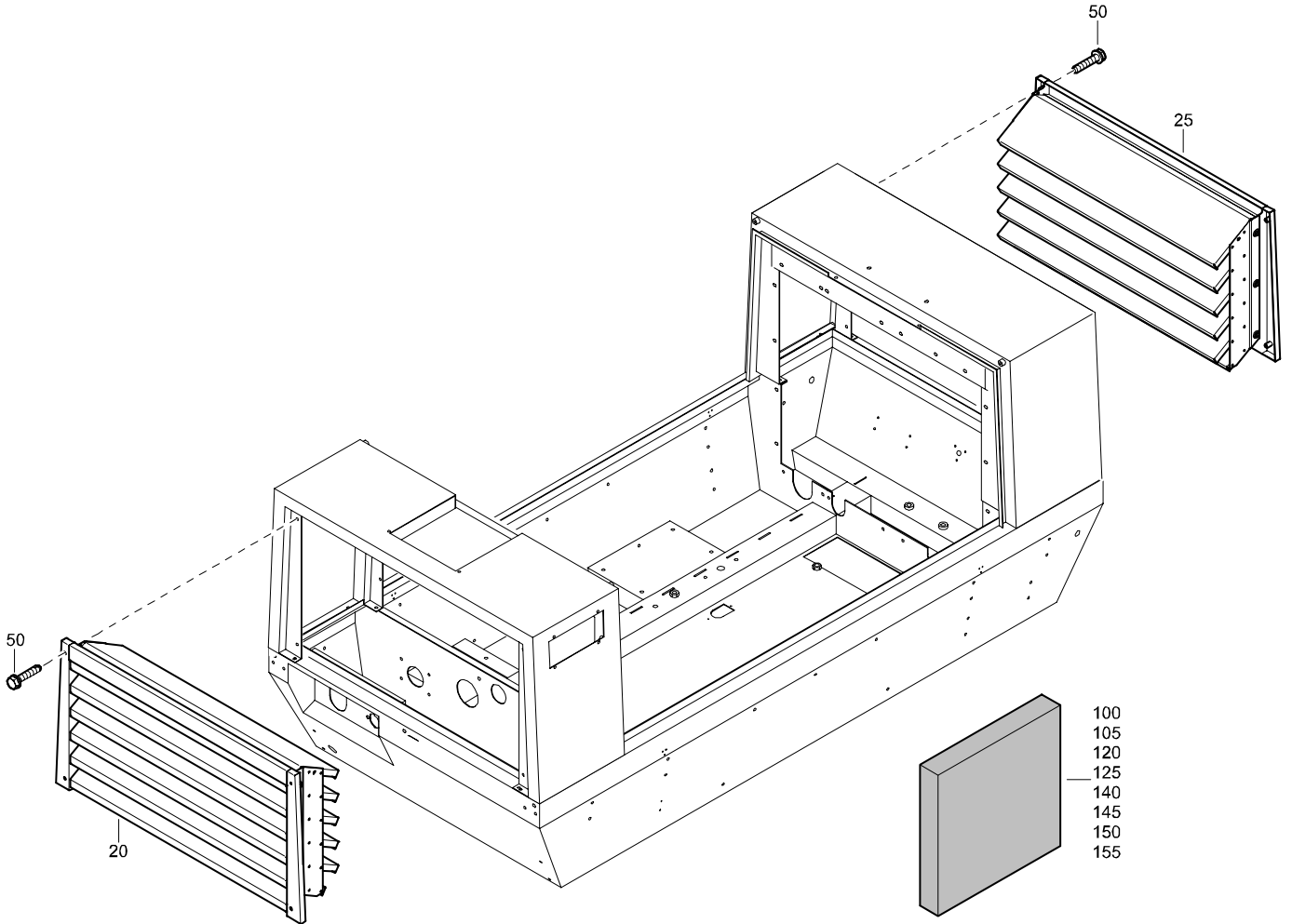

REF	PART NUMBER	DESIGNATION	QTY	REF	PART NUMBER	DESIGNATION	QTY
20	1604 0425 80	ASSEMBLY <i>(For details see page 76)</i>	1	-	1079 0003 33	SILENCING FOAM 2000 mm x 1500 mm x 50 mm	
25	1626 0730 80	ASSEMBLY <i>(For details see page 77)</i>	1				
50	1619 5337 03	HEX. HEAD SCREW	8				
100	-	SILENCING FOAM (50 mm)	1				
105	-	SILENCING FOAM (50 mm)	1				
120	-	SILENCING FOAM (50 mm)	2				
125	-	SILENCING FOAM (50 mm)	1				
140	-	SILENCING FOAM (50 mm)	2				
145	-	SILENCING FOAM (50 mm)	2				
150	-	SILENCING FOAM (50 mm)	1				
155	-	SILENCING FOAM (50 mm)	1				

**STANDARD**  
**ENGINE AND OIL SEPARATOR**  
**FOR COMPRESSOR WITHOUT COLD WEATHER EQUIPMENTS**  
**FOR EC**

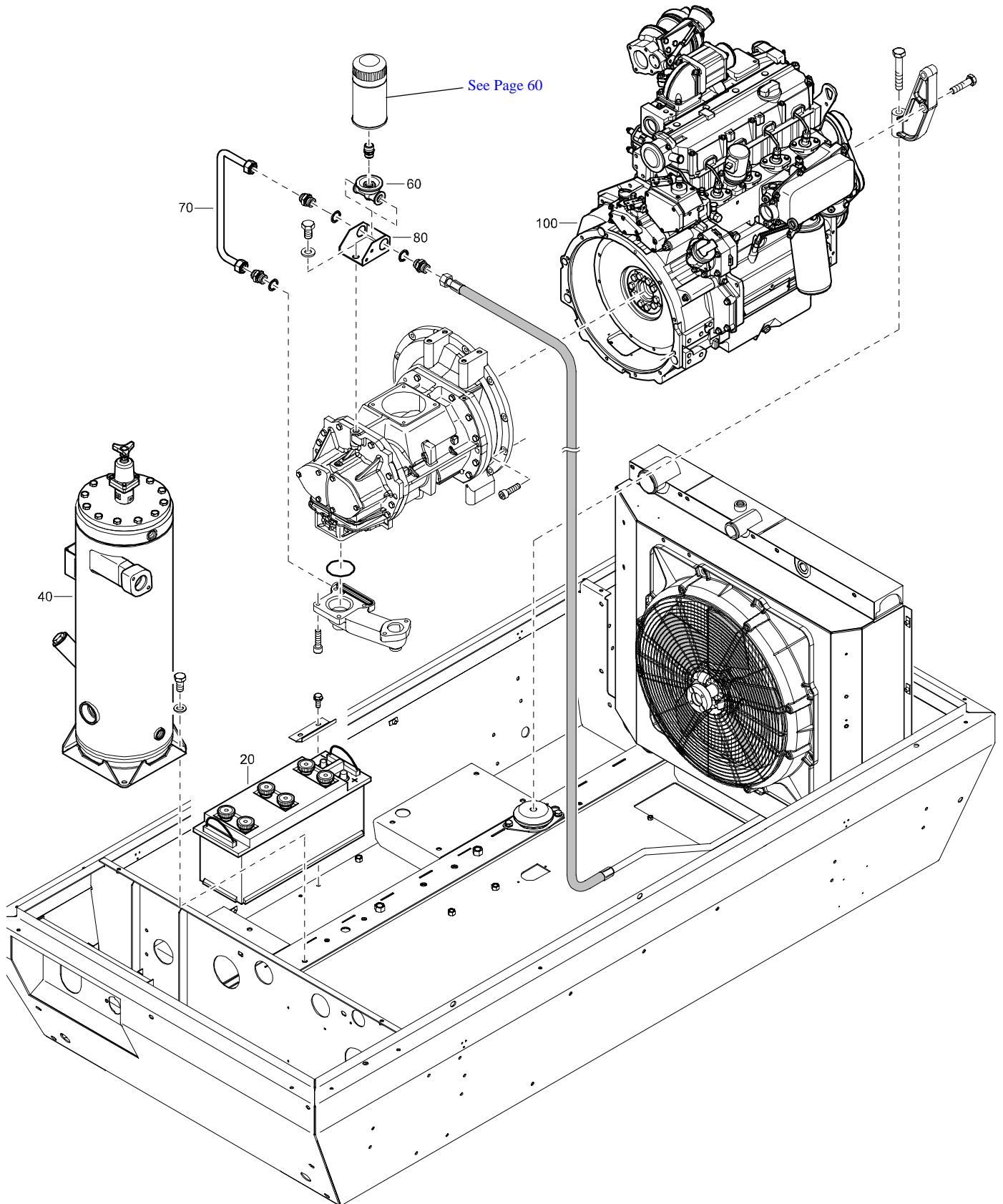

---

**STANDARD**  
**ENGINE AND OIL SEPARATOR**  
**FOR COMPRESSOR WITHOUT COLD WEATHER EQUIPMENTS**  
**FOR EC**

---

<b>REF</b>	<b>PART NUMBER</b>	<b>DESIGNATION</b>	<b>QTY</b>	<b>REF</b>	<b>PART NUMBER</b>	<b>DESIGNATION</b>	<b>QTY</b>
20	0975 8300 17	BATTERY	1				
40	1604 0382 90	OIL SEPARATOR	1				
		<a href="#">(For details see page 70)</a>					
60	1613 6828 00	FILTER HEAD	1				
70	1604 7944 01	PIPE	1				
80	1604 0374 02	BRACKET	1				
100	1626 0129 00	ENGINE	1				

**STANDARD**  
**ENGINE AND PIPE**  
**FOR COMPRESSOR WITHOUT COLD WEATHER EQUIPMENT**  
**FOR ASME**

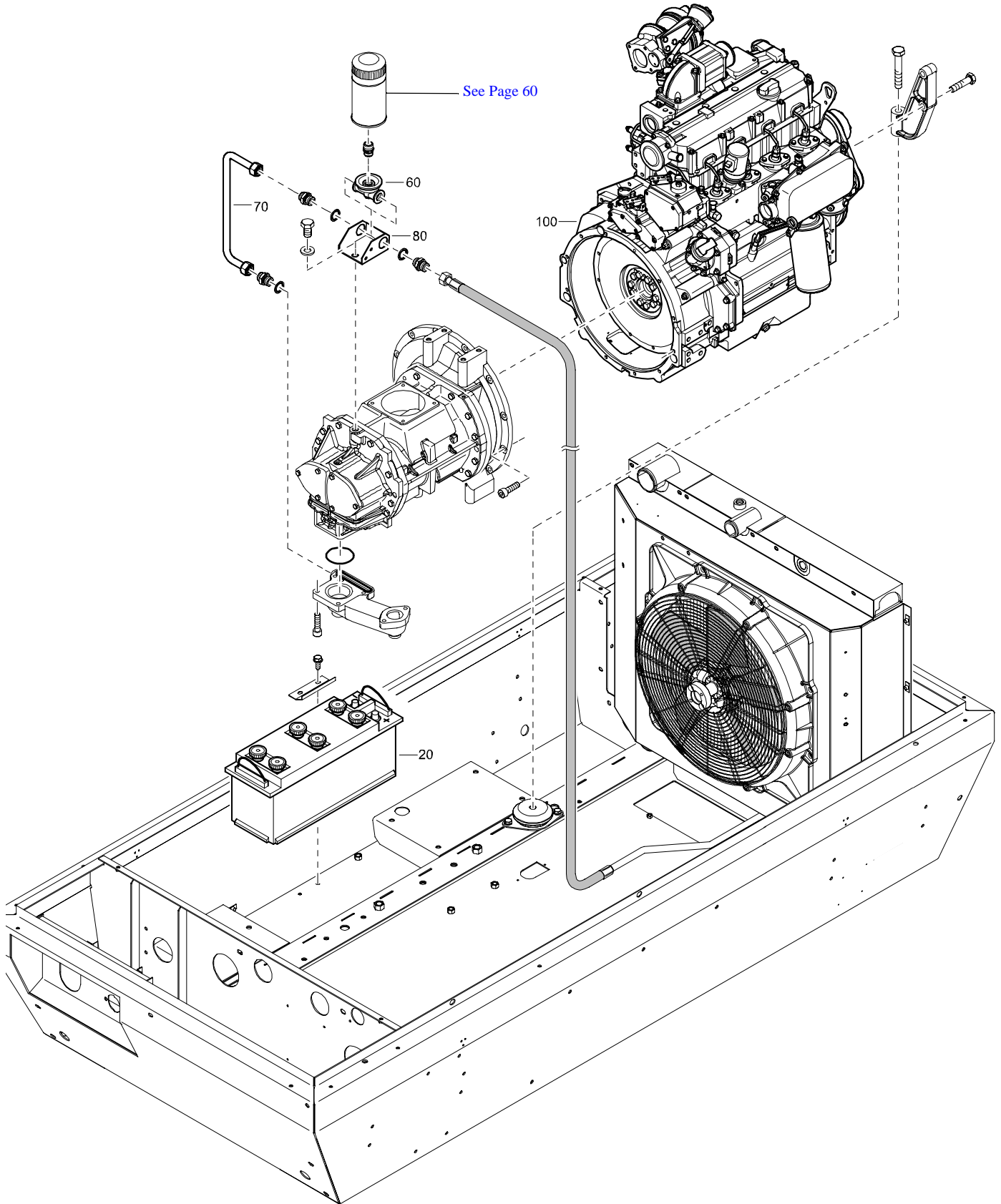



---

**STANDARD**  
**ENGINE AND PIPE**  
**FOR COMPRESSOR WITHOUT COLD WEATHER EQUIPMENT**  
**FOR ASME**

---

<b>REF</b>	<b>PART NUMBER</b>	<b>DESIGNATION</b>	<b>QTY</b>	<b>REF</b>	<b>PART NUMBER</b>	<b>DESIGNATION</b>	<b>QTY</b>
20	0975 8300 17	BATTERY	1				
60	1613 6828 00	FILTER HEAD	1				
70	1604 7944 01	PIPE	1				
80	1604 0374 02	BRACKET	1				
100	1626 0129 00	ENGINE	1				

# STANDARD

## MARKINGS

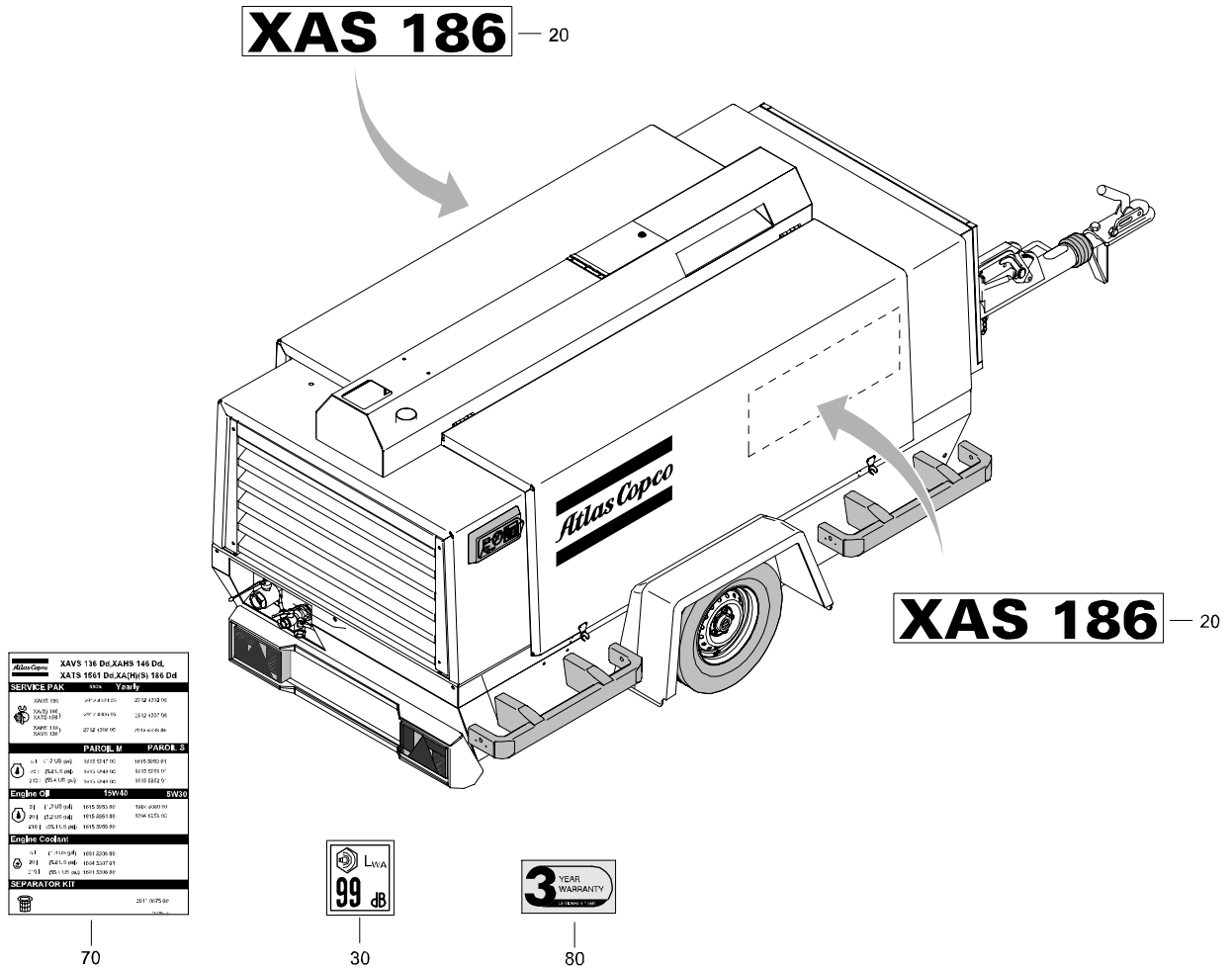

REF	PART NUMBER	DESIGNATION	QTY	REF	PART NUMBER	DESIGNATION	QTY
20	1604 0394 02	DECAL	2				
30	1604 3317 04	LABEL NOISE	1				
70	1079 9924 42	INFORMATION LABEL	1				
80	1604 5797 01	WARRANTY LABEL	2				

# STANDARD

## TOOL BOX FOR COMPRESSORS WITHOUT GENERATOR

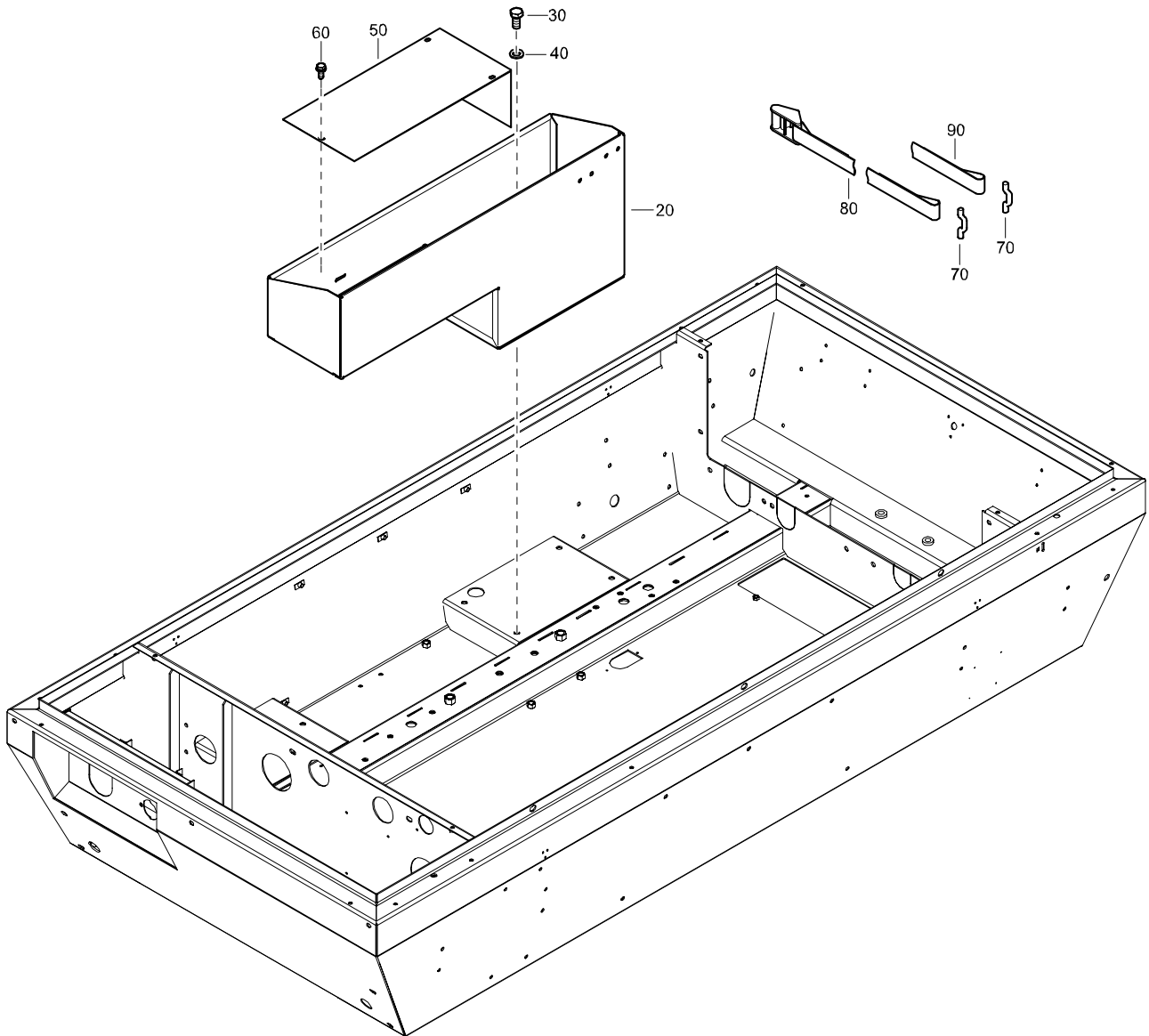

REF	PART NUMBER	DESIGNATION	QTY	REF	PART NUMBER	DESIGNATION	QTY
20	1604 0258 02	TOOL BOX	1				
30	0147 1398 03	HEX. HEAD SCREW	4				
40	0301 2358 00	PLAIN WASHER	4				
50	1604 0259 01	COVER	1				
60	1619 2766 00	BOLT	3				
70	1616 4613 00	RETAINER	4				
80	1616 4614 00	NYLON BAND	2				
90	1616 4615 00	NYLON BAND	2				

---

# STANDARD

## FRAME

---

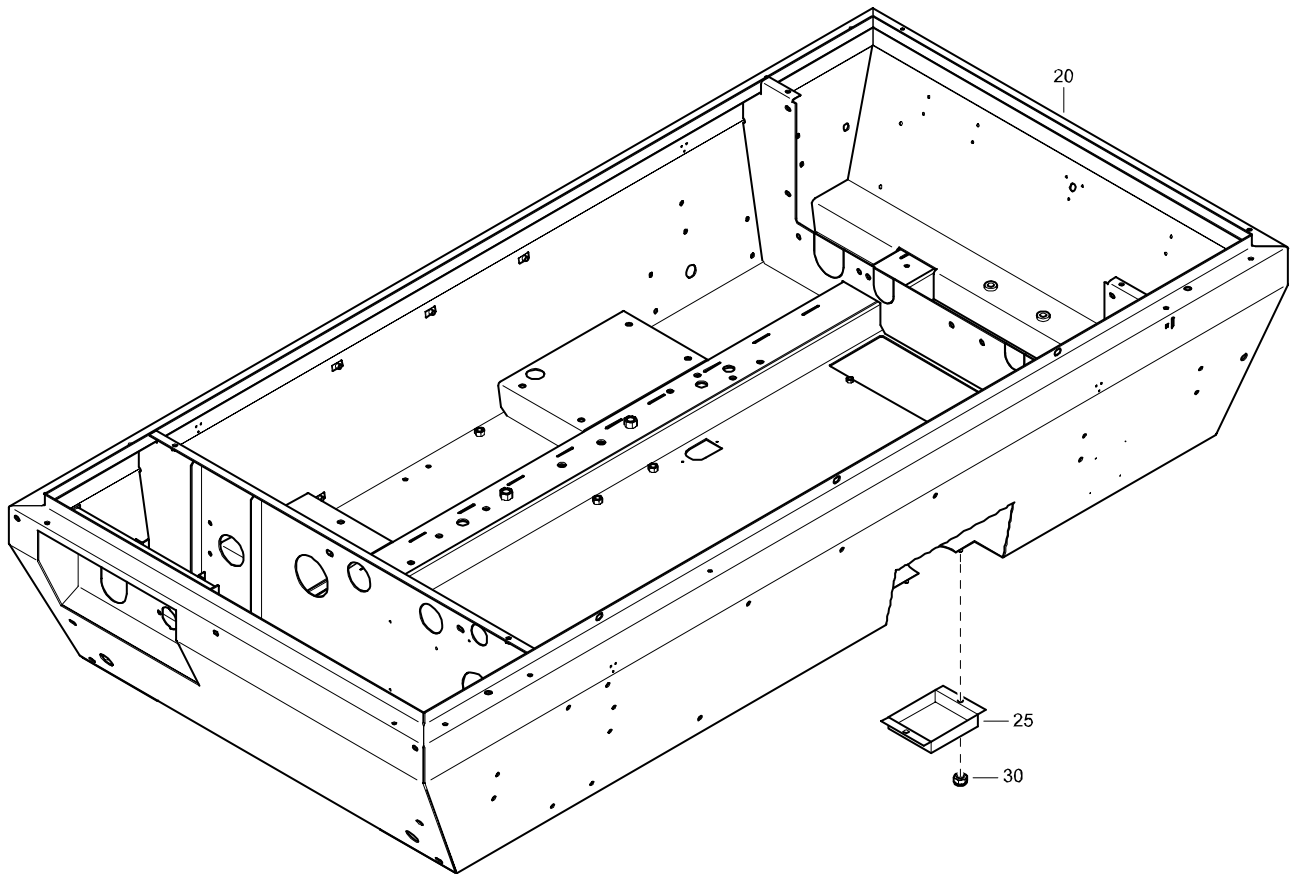

REF	PART NUMBER	DESIGNATION	QTY	REF	PART NUMBER	DESIGNATION	QTY
-	1604 0250 83	FRAME	(From page 32)				
•20	1604 0250 16	FRAME	1				
•25	1604 7001 01	PROTECT COVER	1				
•30	0291 1110 00	LOCKNUT	2				

# STANDARD

## FUELTANK ASSEMBLY

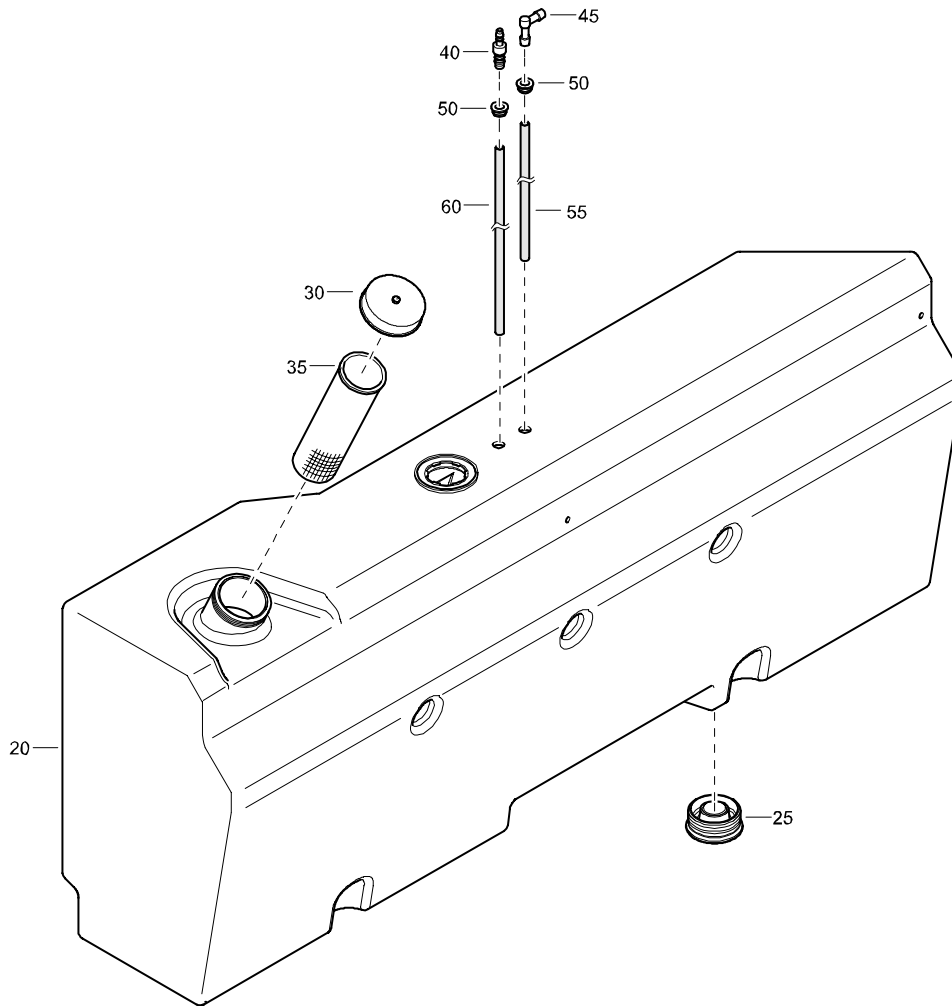

REF	PART NUMBER	DESIGNATION	QTY	REF	PART NUMBER	DESIGNATION	QTY
-	1604 0261 85	FUELTANK ASSEMBLY (From page 34)					
•20	1604 0261 04	FUELTANK	1				
•25	1615 5577 00	PLUG	1				
•30	1615 7653 02	CAP	1				
•35	1615 7654 00	STRAINER	1				
•40	1604 0266 00	REDUCTION	1				
•45	1615 6479 00	ADAPTOR	1				
•50	1615 6480 00	GROMMET	2				
•55	0070 6002 17	PLASTIC TUBE	AR				
•60	0070 6002 17	PLASTIC TUBE	AR				

# STANDARD

## OIL SEPARATOR FOR EC

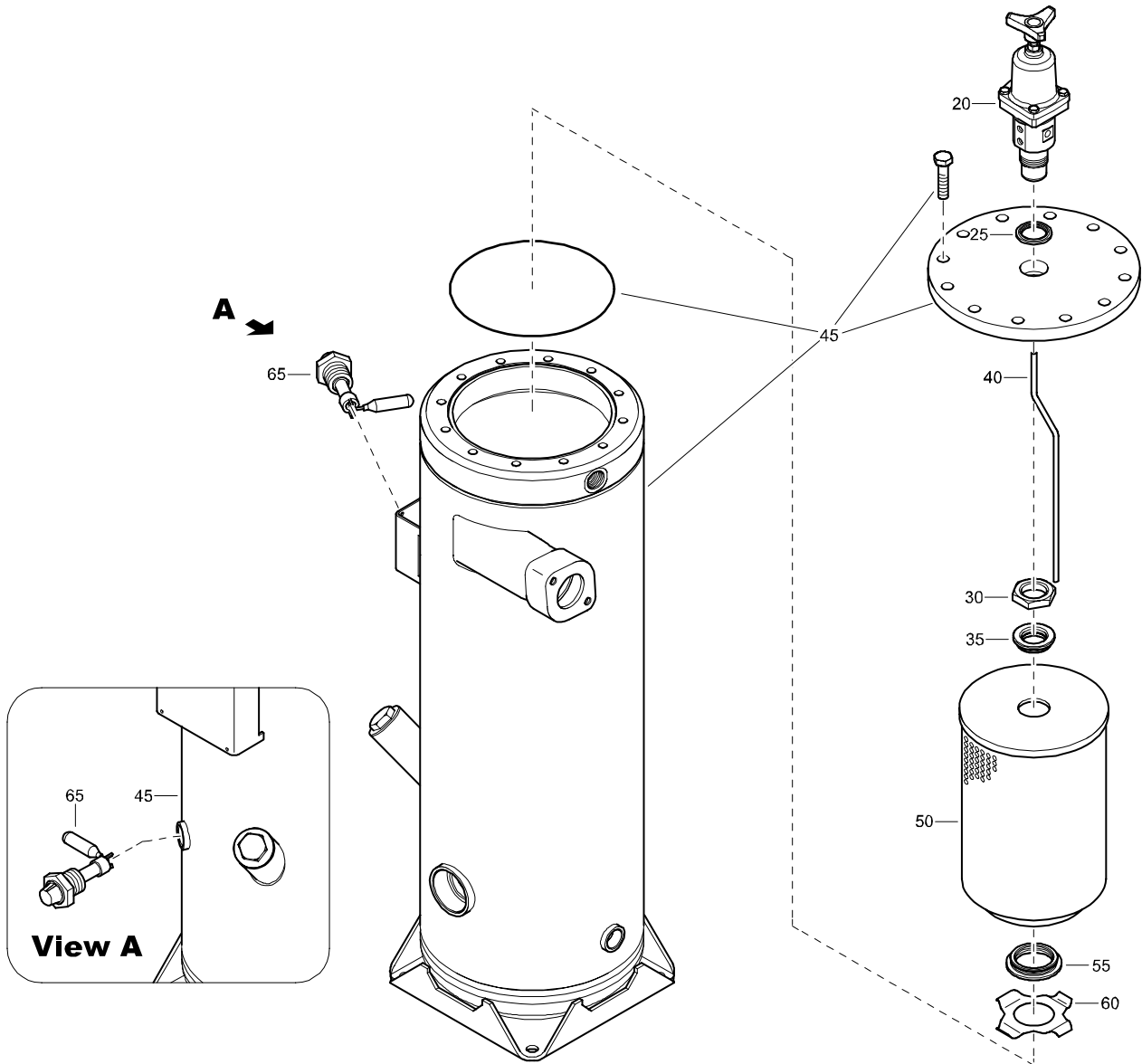

REF	PART NUMBER	DESIGNATION	QTY	REF	PART NUMBER	DESIGNATION	QTY
-	1604 0382 90	OIL SEPARATOR <a href="#">(From page 62)</a>					
•20	1604 0847 84	REGUL VALVE ASSY <a href="#">(For details see page 81)</a>	1				
•25	0661 1049 00	SEALING WASHER	1				
•30	0623 2106 03	BACKNUT	1				
•35	-	SEAL <a href="#">(Part of service kit, see page 27)</a>	1				
•40	1604 0385 01	TUBE	1				
•45	1604 0351 90	PRESSURE VESSEL <a href="#">(For details see page 78)</a>	1				
•50	-	OIL.SEP.ELEMENT <a href="#">(Part of service kit, see page 27)</a>	1				
•55	-	SEAL (OIL SEPARATOR) <a href="#">(Part of service kit, see page 27)</a>	1				
•60	1604 0384 02	RETAINER	1				
•65	1616 5108 00	LEVEL GAUGE	1				

# STANDARD

## OIL SEPARATOR FOR ASME

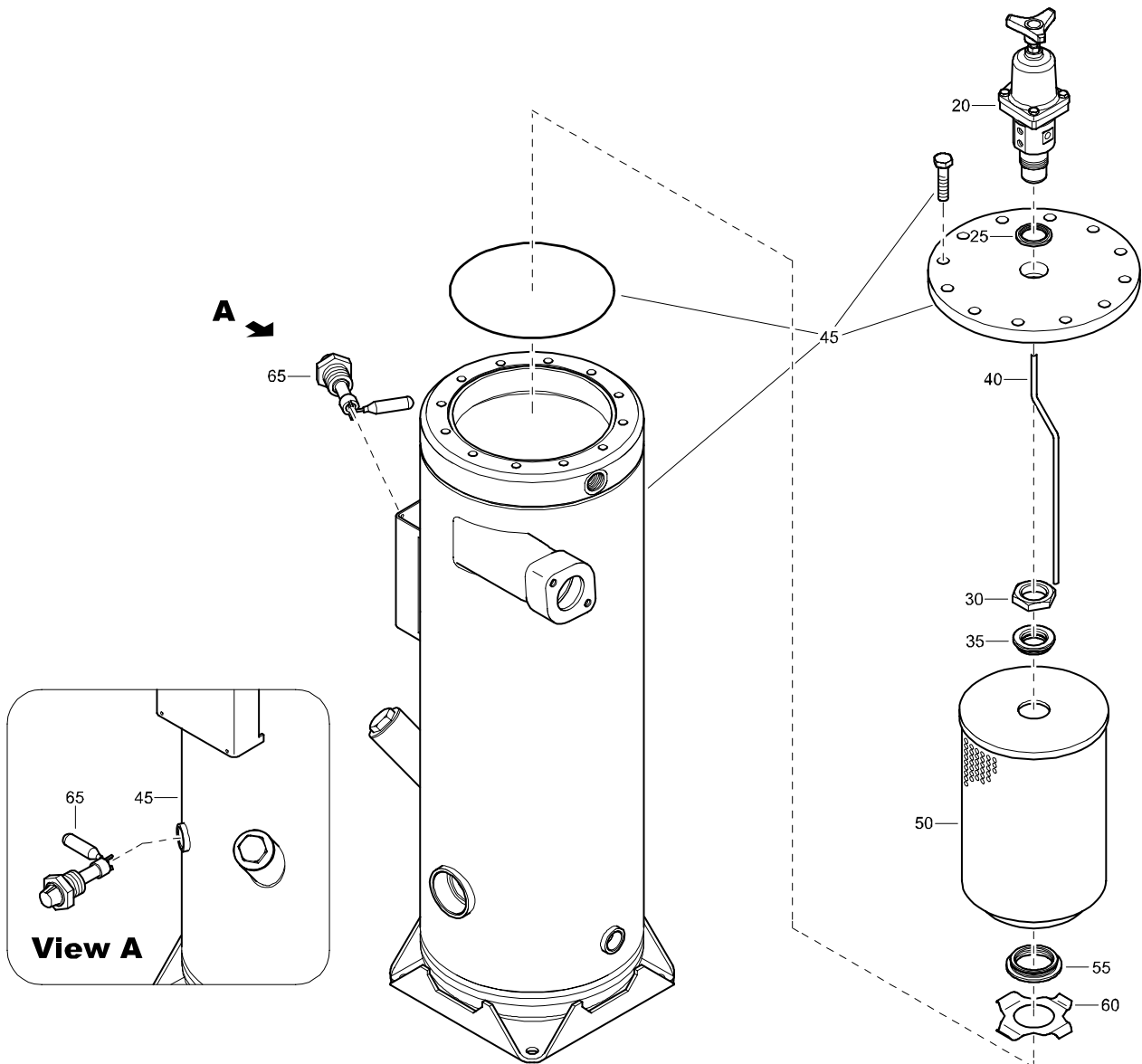

REF	PART NUMBER	DESIGNATION	QTY	REF	PART NUMBER	DESIGNATION	QTY
-	1604 0382 91	OIL SEPARATOR (From page 57, 118)					
•20	1604 0847 84	REGUL VALVE ASSY (For details see page 81)	1				
•25	0661 1049 00	SEALING WASHER	1				
•30	0623 2106 03	BACKNUT	1				
•35	-	SEAL (Part of service kit, see page 27)	1				
•40	1604 0385 01	TUBE	1				
•45	1604 0352 82	PRESSURE VESSEL (For details see page 79)	1				
•50	-	OIL.SEP.ELEMENT (Part of service kit, see page 27)	1				
•55	-	SEAL (OIL SEPARATOR) (Part of service kit, see page 27)	1				
•60	1604 0384 02	RETAINER	1				
•65	1616 5108 00	LEVEL GAUGE	1				

# STANDARD

## INSTRUMENT PANEL ASSEMBLY

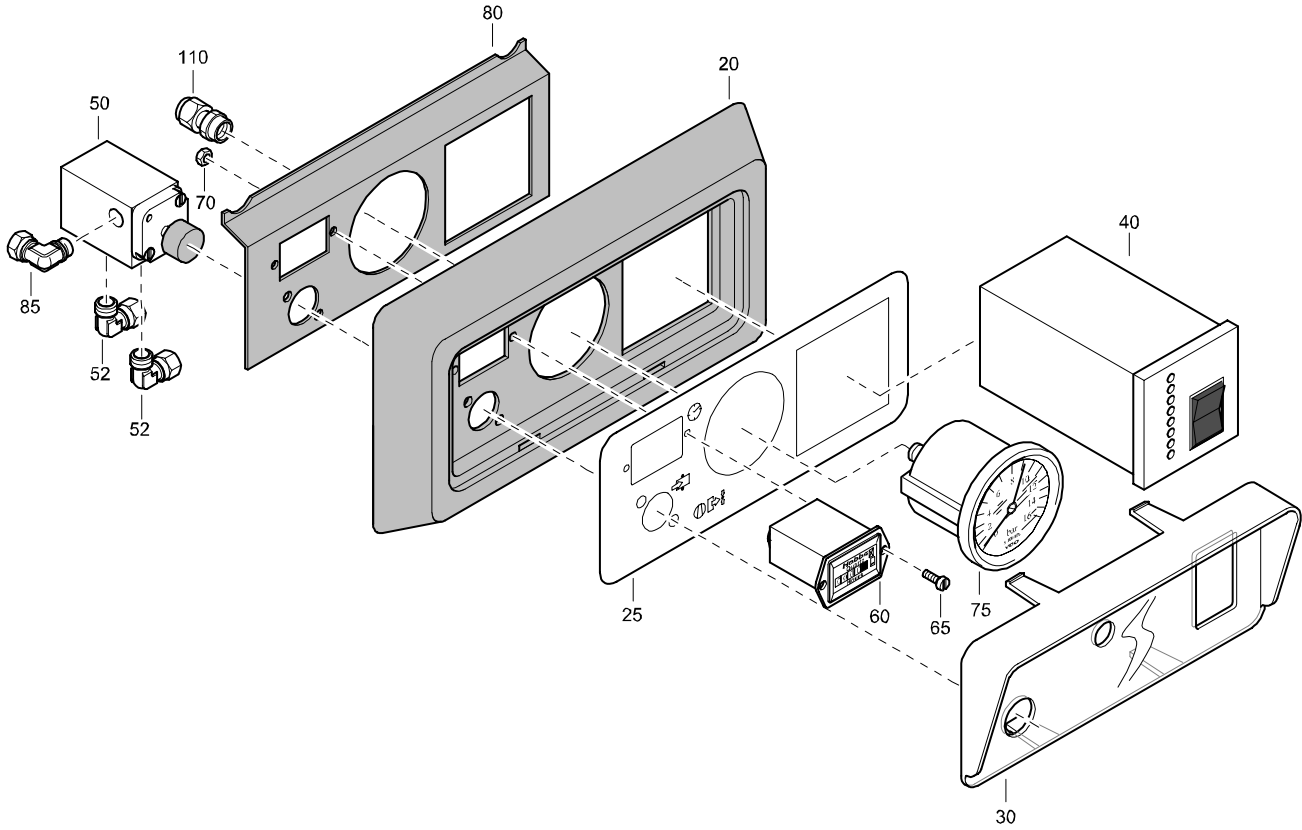

REF	PART NUMBER	DESIGNATION	QTY	REF	PART NUMBER	DESIGNATION	QTY
-	1604 0471 85	INSTRUMENT PANEL ASSEMBLY (From page 48)					
•20	1604 0471 01	PANEL	1				
•25	1604 0476 00	LABEL	1				
•30	1604 0472 02	WINDOW	1				
•40	1089 9355 97	MODULE	1				
•50	1604 0315 81	LOAD VALVE ASS'Y (For details see page 80)	1				
•52	0581 1200 23	ELBOW PIPE COUPLING	2				
•60	1089 9420 01	HOURMETER	1				
•65	0160 6040 00	SLOTTED SCREW	2				
•70	0266 2106 00	HEXAGON NUT	2				
•75	1615 7264 00	PRESSURE GAUGE	1				
•80	1604 0473 02	PLATE	1				
•85	0581 1200 30	ELBOW PIPE COUPLING	1				
•110	0584 0080 09	STRAIGHT PIPE COUPLING	1				



# STANDARD

## ENGINE SPEED REGULATOR

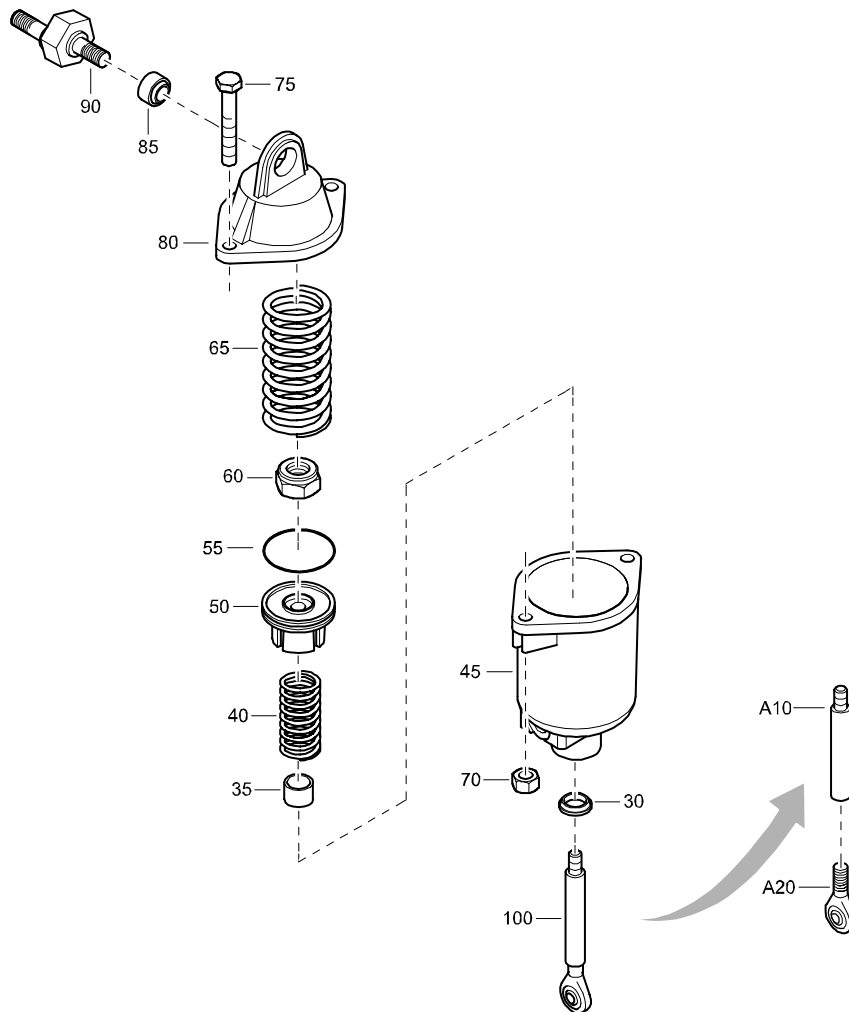

REF	PART NUMBER	DESIGNATION	QTY	REF	PART NUMBER	DESIGNATION	QTY
-	1604 0321 80	ACTUATING UNIT (ASSY)(From page 40)					
•30	-	WIPER (Part of service kit, see page 24)	1				
•35	-	PLAIN BEARING (Not available separately)	1				
•40	2252 0489 00	COMPR.SPRING	1				
•45	-	HOUSING (ACTUATING UNIT) (Not available separately)	1				
•50	1615 8755 00	PISTON	1				
•55	-	PISTON SEAL (Part of service kit, see page 24)	1				
•60	0291 1110 00	LOCKNUT	2				
•65	1615 8369 00	SPRING	1				
•70	0266 2108 00	HEXAGON NUT	2				
•75	0147 1252 12	HEX .HEAD SCREW	2				
•80	-	COVER (Not available separately)	1				
•85	0501 0007 00	SPHERICAL PLAIN BEARING	1				
•90	1615 8382 00	ADAPTOR	1				
•100	1615 8756 80	PISTON	1				
•A10	1615 8756 01	PISTON ROD	1				
•A20	1615 9770 00	EYE BOLT WITH BEARING	1				

# STANDARD

## UNLOADING VALVE ASSEMBLY

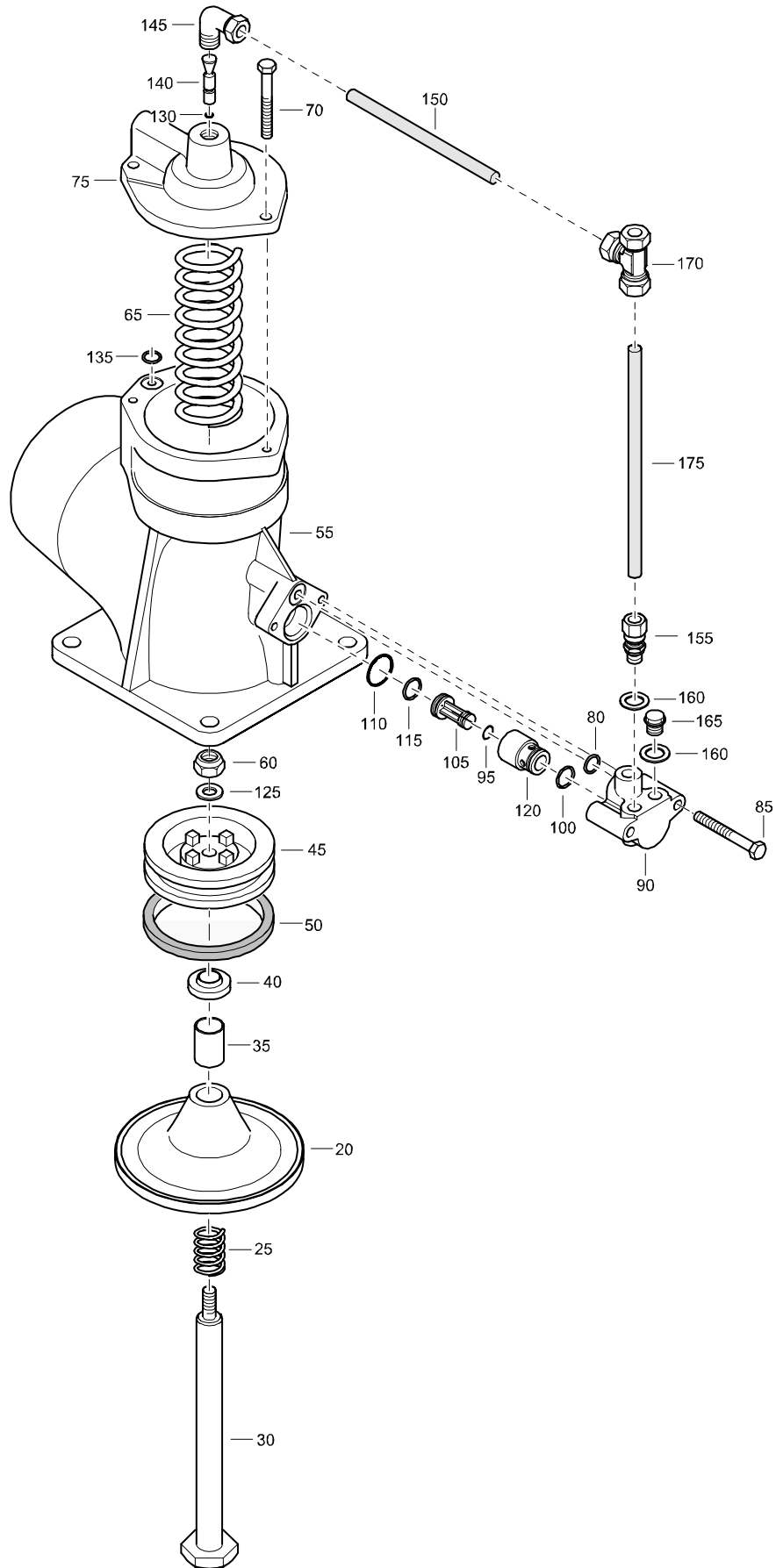

# STANDARD

## UNLOADING VALVE ASSEMBLY

REF	PART NUMBER	DESIGNATION	QTY	REF	PART NUMBER	DESIGNATION	QTY
-	1604 0306 83	UNLOADING VALVE ASSEMBLY					
		(From page 40)					
•20	-	VALVE (UNL. VALVE)	1				
		(Part of service kit, see page 26)					
•25	-	SPRING	1				
		(Part of service kit, see page 26)					
•30	1604 0307 00	PISTON ROD (UNL.VALVE)	1				
•35	-	PLAIN BEARING	1				
		(Not available separately)					
•40	-	WIPER	1				
		(Not available separately)					
•45	1604 0310 00	PISTON (UNLOADING VALVE)	1				
•50	-	PISTON SEAL	1				
		(Part of service kit, see page 26)					
•55	-	HOUSING (UNLOADER)	1				
		(Not available separately)					
•60	-	LOCKNUT	1				
		(Part of service kit, see page 26)					
•65	1604 0311 00	SPRING	1				
•70	0147 1962 76	HEXAGON HEAD SCREW	3				
•75	-	HOUSING	1				
		(Not available separately)					
•80	-	O-RING	1				
		(Part of service kit, see page 26)					
•85	0147 1252 03	HEXAGON HEAD SCREW	2				
•90	-	HOUSING	1				
		(Not available separately)					
•95	-	O-RING	1				
		(Part of service kit, see page 26)					
•100	-	O-RING	1				
		(Part of service kit, see page 26)					
•105	-	VALVE	1				
		(Part of service kit, see page 26)					
•110	-	O-RING	1				
		(Part of service kit, see page 26)					
•115	-	O-RING	1				
		(Part of service kit, see page 26)					
•120	1615 8345 01	BUSHING	1				
•125	-	PLAIN WASHER	1				
		(Part of service kit, see page 26)					
•130	-	O-RING	1				
		(Part of service kit, see page 26)					
•135	-	O-RING	1				
		(Part of service kit, see page 26)					
•140	1604 0313 00	VALVE	1				
•145	0581 1200 23	STRAIGHT PIPE COUPLING	1				
•150	0070 6002 04	PLASTIC TUBE	AR				
•155	0582 1200 05	CUTTING RING COUPLING IN BRASS	1				
•160	0653 1043 00	FLAT GASKET	2				
•165	0686 4201 03	HEXAGON PLUG	1				
•170	0582 1200 12	CUTTING RING COUPLING IN BRASS	1				
•175	0070 6002 05	PLASTIC TUBE	AR				

# STANDARD

## ASSEMBLY

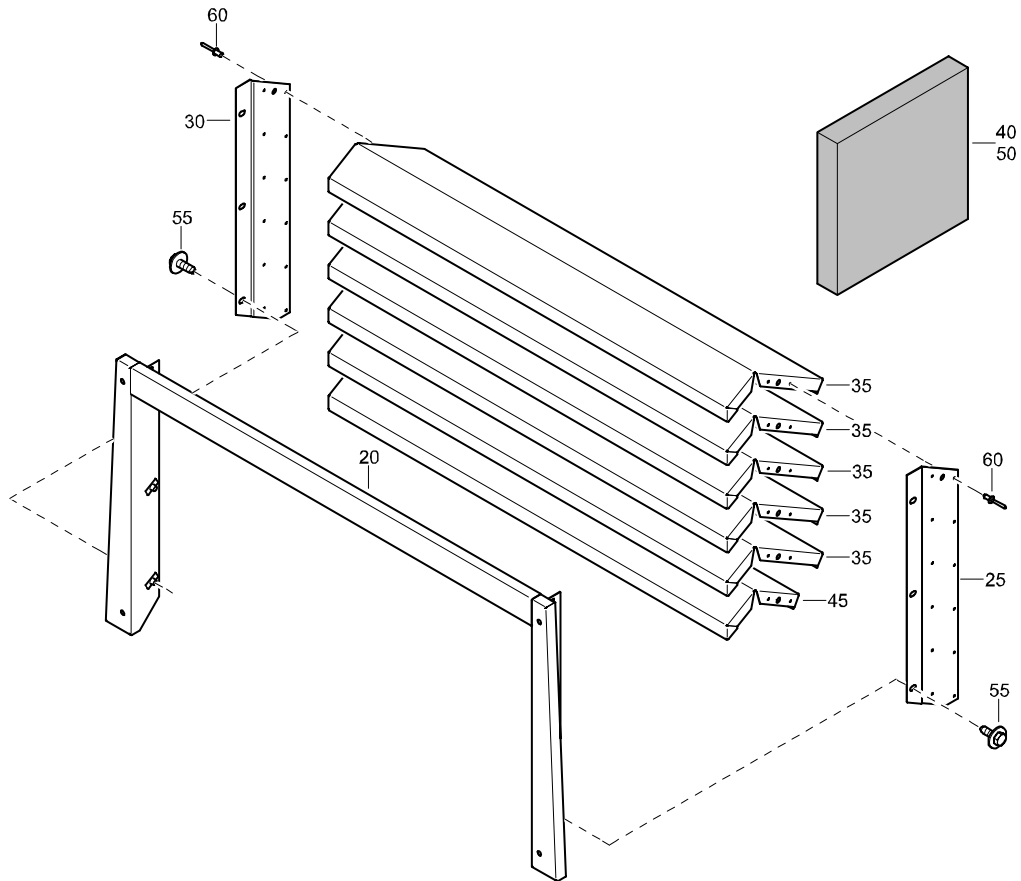

REF	PART NUMBER	DESIGNATION	QTY	REF	PART NUMBER	DESIGNATION	QTY
-	1604 0425 80	ASSEMBLY	(From page 61)				
•20	1604 0425 03	BAFFLE	1				
•25	1604 0428 02	PLATE	1				
•30	1604 0426 02	PLATE	1				
•35	1604 0427 02	PLATE	5				
•40	-	SILENCING FOAM (30 mm)	5				
•45	1604 0286 00	BAFFLE	1				
•50	-	SILENCING FOAM (30 mm)	1				
•55	1615 5664 00	HEX. HEAD SCREW	6				
•60	0129 3174 01	BLIND RIVET	24				
-	1079 0003 32	SILENCING FOAM					
		2000 mm x 1500 mm x 30 mm					

# STANDARD

## ASSEMBLY

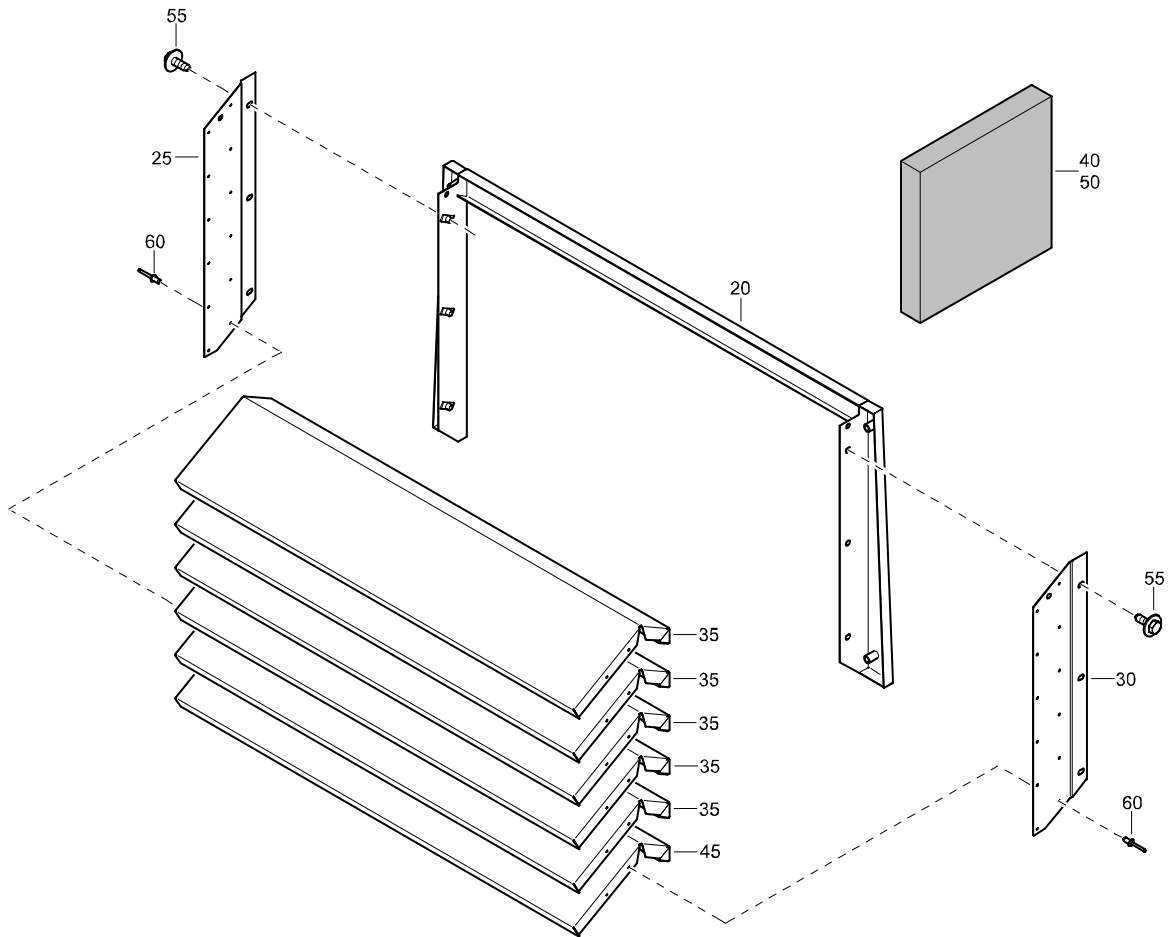

REF	PART NUMBER	DESIGNATION	QTY	REF	PART NUMBER	DESIGNATION	QTY
-	1626 0730 80	ASSEMBLY	(From page 61)				
•20	1626 0730 00	BAFFLE	1				
•25	1626 0731 00	PLATE	1				
•30	1626 0732 00	PLATE	1				
•35	1626 0733 00	BAFFLE	5				
•40	-	SILENCING FOAM (30 mm)	5				
•45	1626 0734 00	BAFFLE	1				
•50	-	SILENCING FOAM (30 mm)	1				
•55	1615 5664 00	HEX. HEAD SCREW	6				
•60	0129 3174 01	BLIND RIVET	24				
-	1079 0003 32	SILENCING FOAM 2000 mm x 1500 mm x 30 mm					

# STANDARD

## PRESSURE VESSEL FOR EC

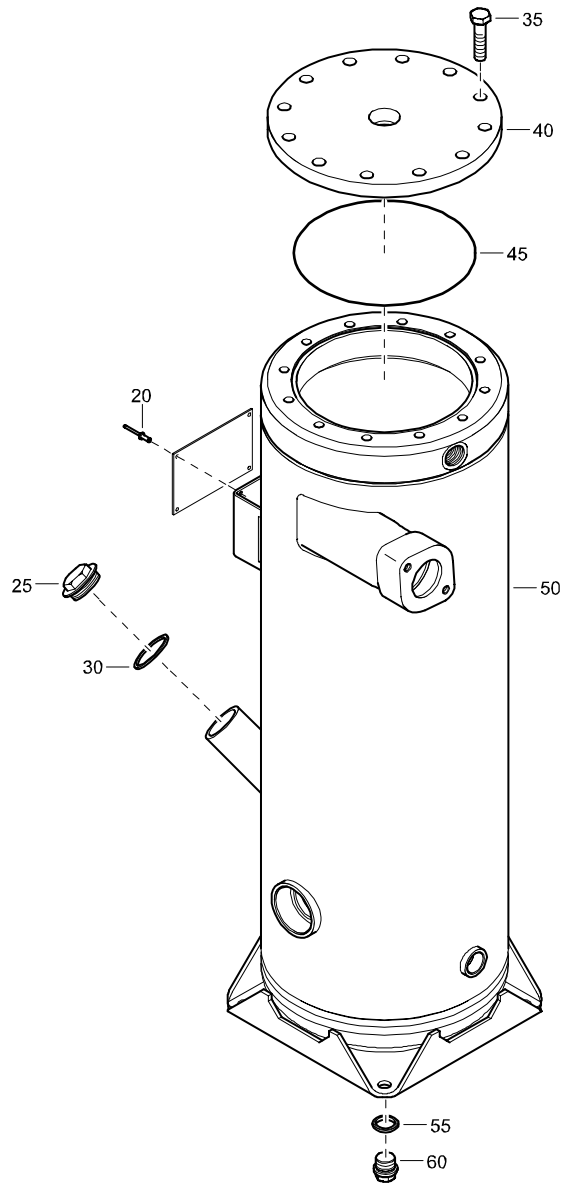

REF	PART NUMBER	DESIGNATION	QTY	REF	PART NUMBER	DESIGNATION	QTY
-	1604 0351 90	PRESSURE VESSEL	(From page 70)				
•20	0129 3115 00	BLIND RIVET	4				
•25	2250 2528 00	PLUG SCREW	1				
•30	0653 1227 00	FLAT GASKET	1				
•35	0147 1403 20	HEX. HEAD SCREW	12				
•40	1604 0386 00	COVER	1				
•45	-	O-RING	1				
		(Part of service kit, see page 27)					
•50	1604 0351 00	VESSEL	1				
•55	0661 1033 00	SEALING WASHER	1				
•60	0686 3716 02	HEXAGON PLUG	1				

# STANDARD

## PRESSURE VESSEL FOR ASME

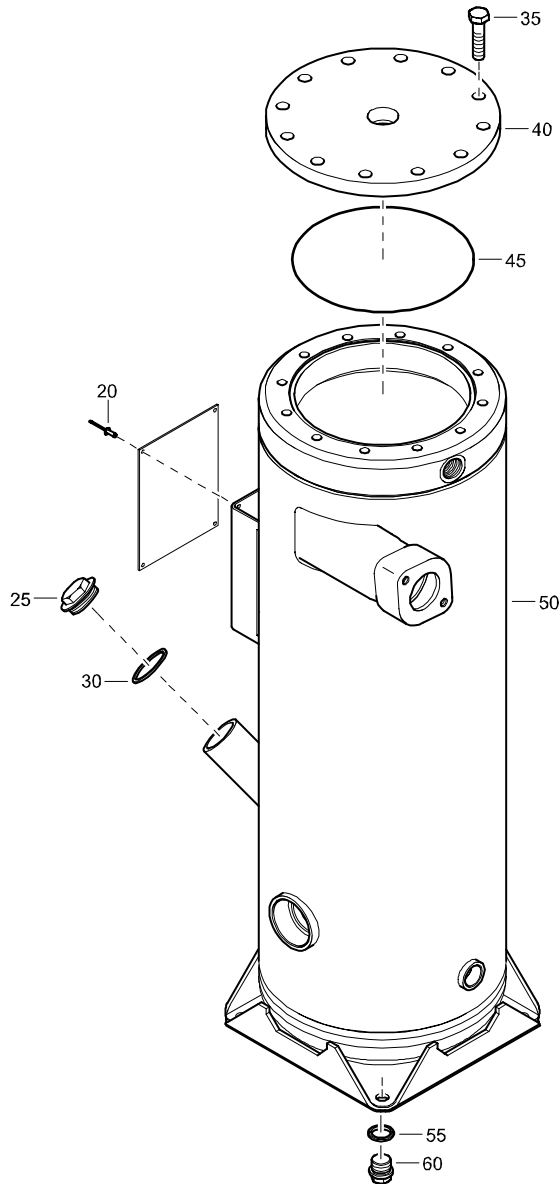

REF	PART NUMBER	DESIGNATION	QTY	REF	PART NUMBER	DESIGNATION	QTY
-	1604 0352 82	PRESSURE VESSEL	(From page 71)				
•20	0129 3115 00	BLIND RIVET	4				
•25	2250 2528 00	PLUG SCREW	1				
•30	0653 1227 00	FLAT GASKET	1				
•35	0147 1403 20	HEX. HEAD SCREW	12				
•40	1604 0386 00	COVER	1				
•45	-	O-RING	1				
		(Part of service kit, see page 27)					
•50	1604 0352 00	VESSEL	1				
•55	0661 1033 00	SEALING WASHER	1				
•60	0686 3716 02	HEXAGON PLUG	1				

# STANDARD

## LOAD VALVE ASSEMBLY

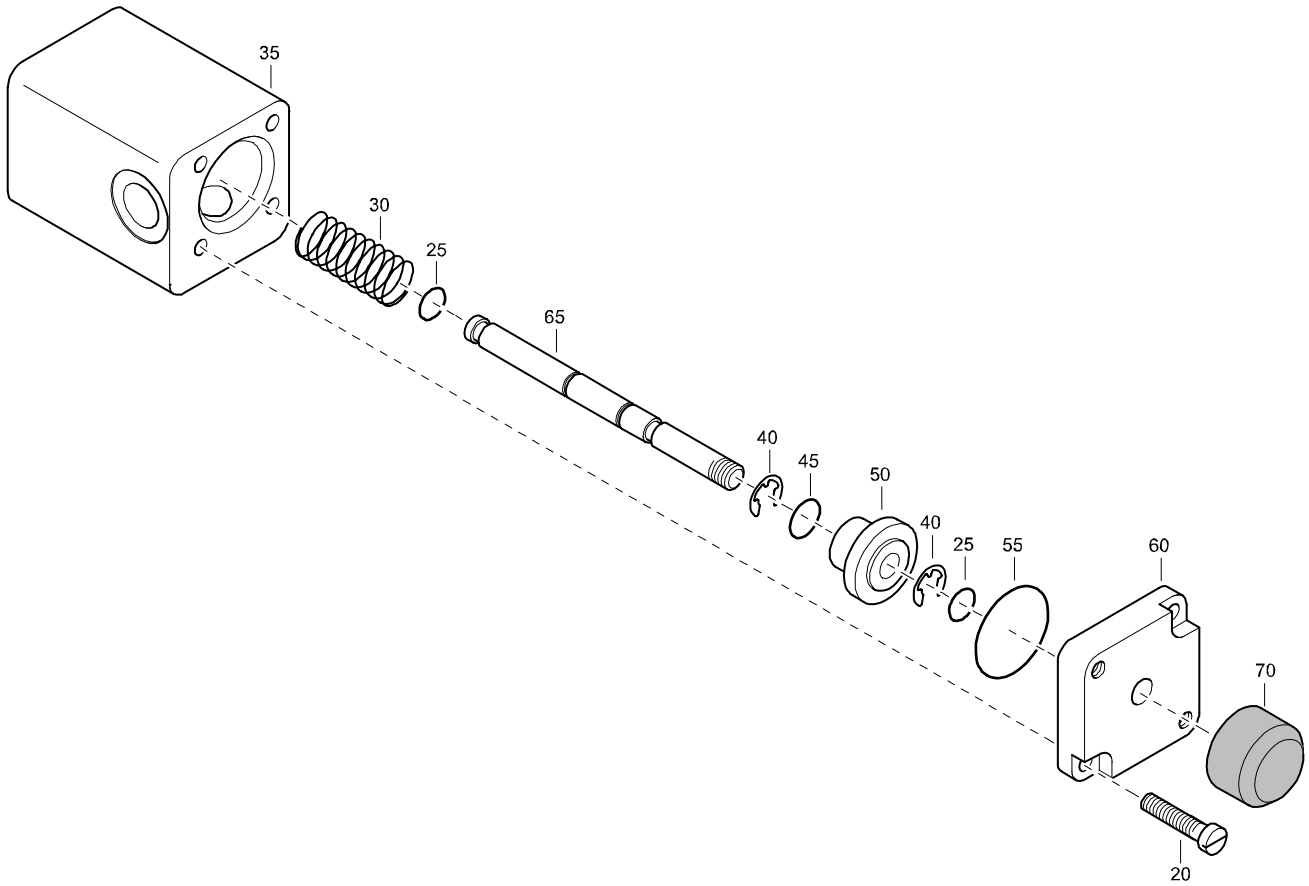

REF	PART NUMBER	DESIGNATION	QTY	REF	PART NUMBER	DESIGNATION	QTY
-	1604 0315 81	LOAD VALVE ASS'Y (From page 72)					
•20	0160 6060 00	SLOTTED SCREW	2				
•25	-	O-RING (Part of service kit, see page 30)	3				
•30	1604 0319 00	SPRING	1				
•35	1604 0316 01	HOUSING	1				
•40	0335 3106 00	RETAINING RING	2				
•45	-	O-RING (Part of service kit, see page 30)	1				
•50	1604 0317 00	VALVE	1				
•55	-	O-RING (Part of service kit, see page 30)	1				
•60	1613 2614 00	COVER	1				
•65	1604 0318 00	VALVE ROD	1				
•70	1613 2616 00	KNOB	1				



# STANDARD

## REGULATING VALVE ASSEMBLY

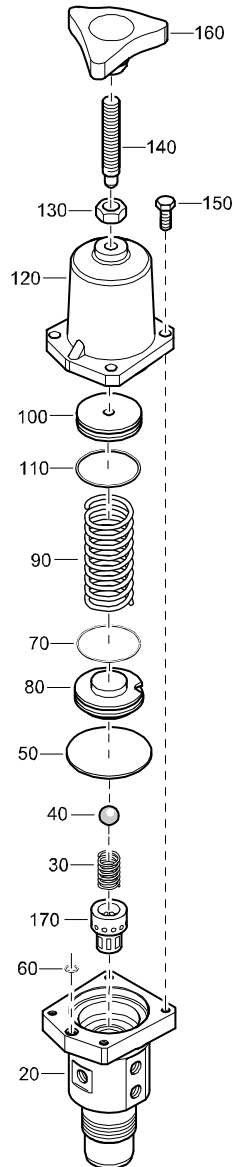

REF	PART NUMBER	DESIGNATION	QTY	REF	PART NUMBER	DESIGNATION	QTY
-	1604 0847 84	REGUL VALVE ASSY (From page 70, 71)		•160	1604 0850 03	HANDLE	1
•20	-	HOUSING (Not available separately)	1	•170	2252 4057 00	BALL CAGE	1
•30	-	SPRING (Part of service kit, see page 28)	1				
•40	-	BEARING BALL (Part of service kit, see page 28)	1				
•50	-	MEMBRANE (Part of service kit, see page 28)	1				
•60	-	O-RING (Part of service kit, see page 28)	1				
•70	-	O-RING (Part of service kit, see page 28)	1				
•80	2252 4058 00	SPRING GUIDE	1				
•90	2252 1428 00	SPRING	1				
•100	2252 4059 01	SPRING SEAT	1				
•110	-	O-RING (Part of service kit, see page 28)	1				
•120	-	SPRING COVER (Not available separately)	1				
•130	0266 2110 00	HEXAGON NUT	1				
•140	1604 0849 02	SCREW	1				
•150	0147 1247 03	HEX. HEAD SCREW	4				

# OPTIONS

## TOWING EYES AC EYE, BALL COUPLING-WITH BRAKES, DIN EYE

### AC EYE

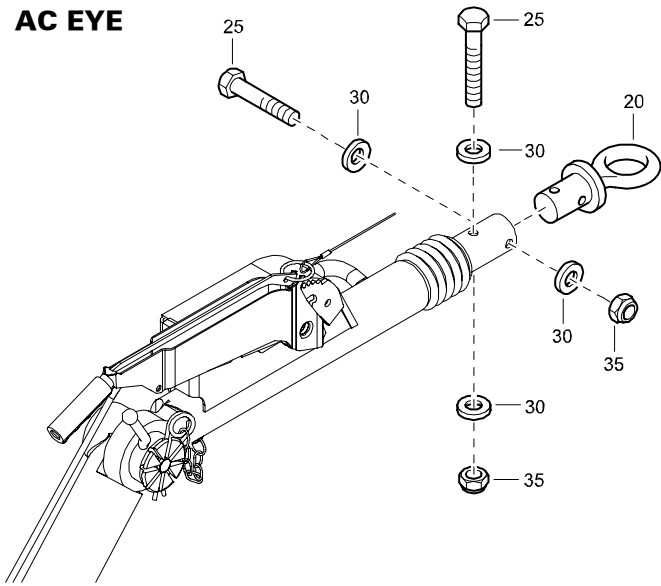

REF	PART NUMBER	DESIGNATION	QTY
20	1614 4368 00	A.C. EYE	1
25	1202 9844 02	BOLT	2
30	1202 9845 00	WASHER	4
35	0291 1185 13	LOCKNUT	2

1611 7701 12/00

### BALL COUPLING - WITH BRAKES

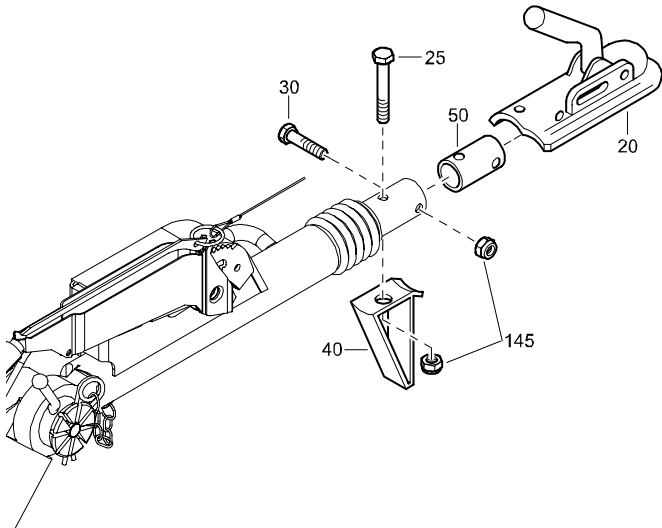

REF	PART NUMBER	DESIGNATION	QTY
20	1619 7273 00	BALL COUPLING	1
25	1202 9844 05	BOLT	1
30	1202 9844 02	BOLT	1
40	1619 7213 00	SUPPORT	1
50	1202 9732 00	BUSH	1
145	0291 1185 13	LOCKNUT	2

1611 7701 39/00

### DIN EYE

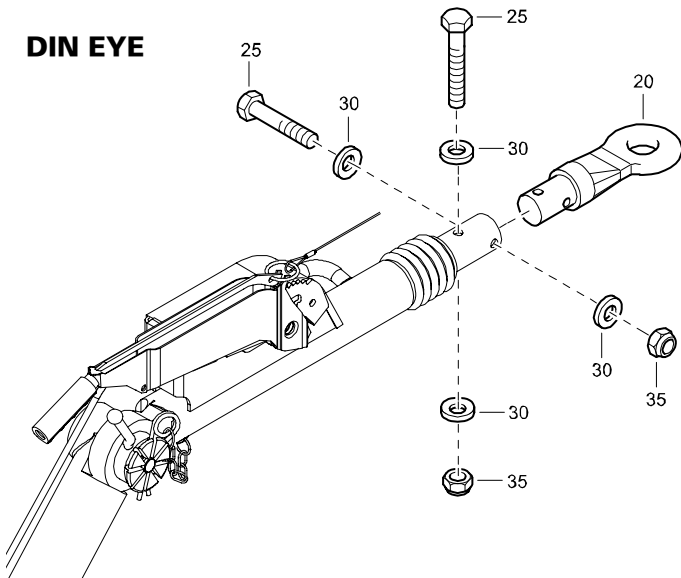

REF	PART NUMBER	DESIGNATION	QTY
20	1614 4392 00	DIN EYE	1
25	1202 9844 02	BOLT	2
30	1202 9845 00	WASHER	4
35	0291 1185 13	LOCKNUT	2

1611 7702 12/00

# OPTIONS

## TOWING EYES BALL COUPLING, ITA EYE, NATO EYE

### BALL COUPLING - BRAKES LOOSE

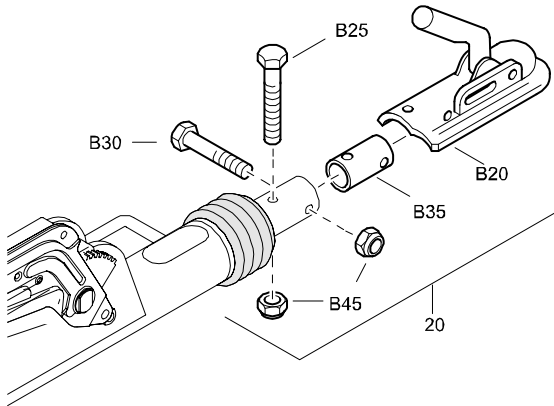

REF	PART NUMBER	DESIGNATION	QTY
20	1619 7273 80	BALL COUPLING	1
•B20	1619 7273 00	BALL COUPLING	1
•B25	0147 1412 03	HEXAGON HEAD SCREW	1
•B30	0147 1411 03	HEXAGON HEAD SCREW	1
•B35	1202 9732 00	BUSH	2
•B45	0291 1112 00	LOCKNUT	2

1611 7703 84/00

### ITA EYE - WITH BRAKES

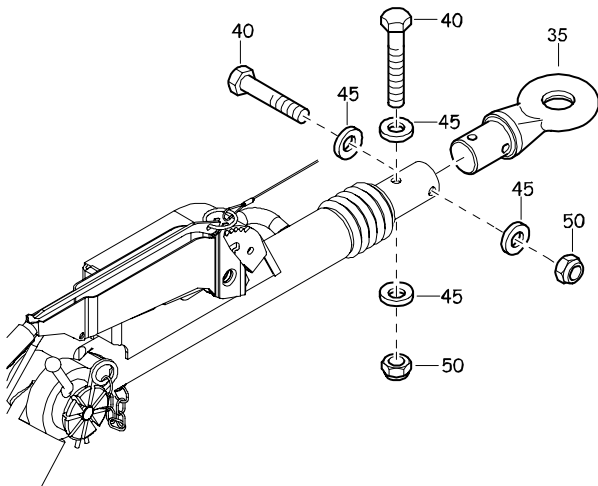

REF	PART NUMBER	DESIGNATION	QTY
35	1615 6820 02	TOWING EYE	1
40	1202 9844 02	BOLT	2
45	1202 9845 00	WASHER	4
50	0291 1185 13	LOCKNUT	2

1611 7704 12/04

### NATO EYE

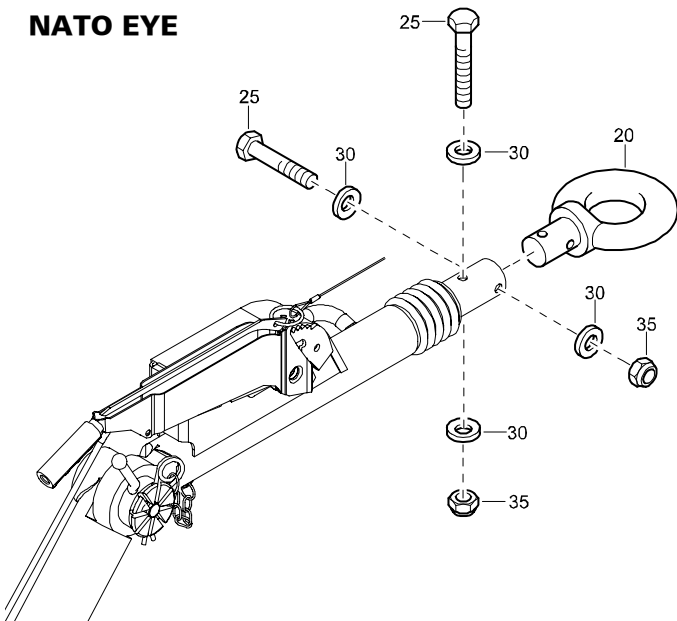

REF	PART NUMBER	DESIGNATION	QTY
20	1614 4678 00	NATO EYE	1
25	1202 9844 02	BOLT	2
30	1202 9845 00	WASHER	4
35	0291 1185 13	LOCKNUT	2

1611 7707 12/00

# OPTIONS

## COSMOS GLOBAL COVERAGE WITH GPRS NETWORK

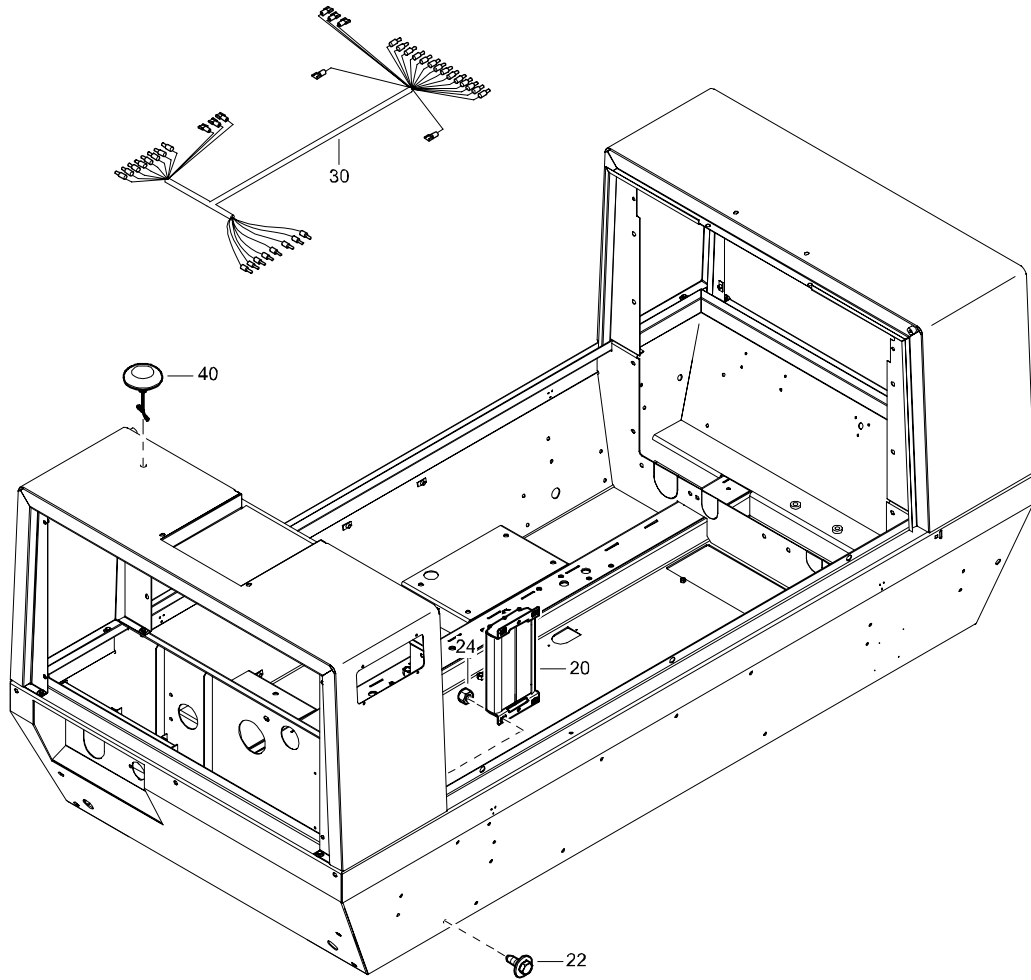

REF	PART NUMBER	DESIGNATION	QTY	REF	PART NUMBER	DESIGNATION	QTY
20	1604 7945 00	COSMOS MODULE	1				
22	1615 5664 00	HEX. HEAD SCREW	4				
24	0266 2110 00	HEXAGON NUT	4				
30	1626 0087 00	WIRING COSMOS	1				
40	1604 7837 00	ANTENNA	1				

# OPTIONS

## COSMOS GLOBAL COVERAGE WITH CDMA NETWORK

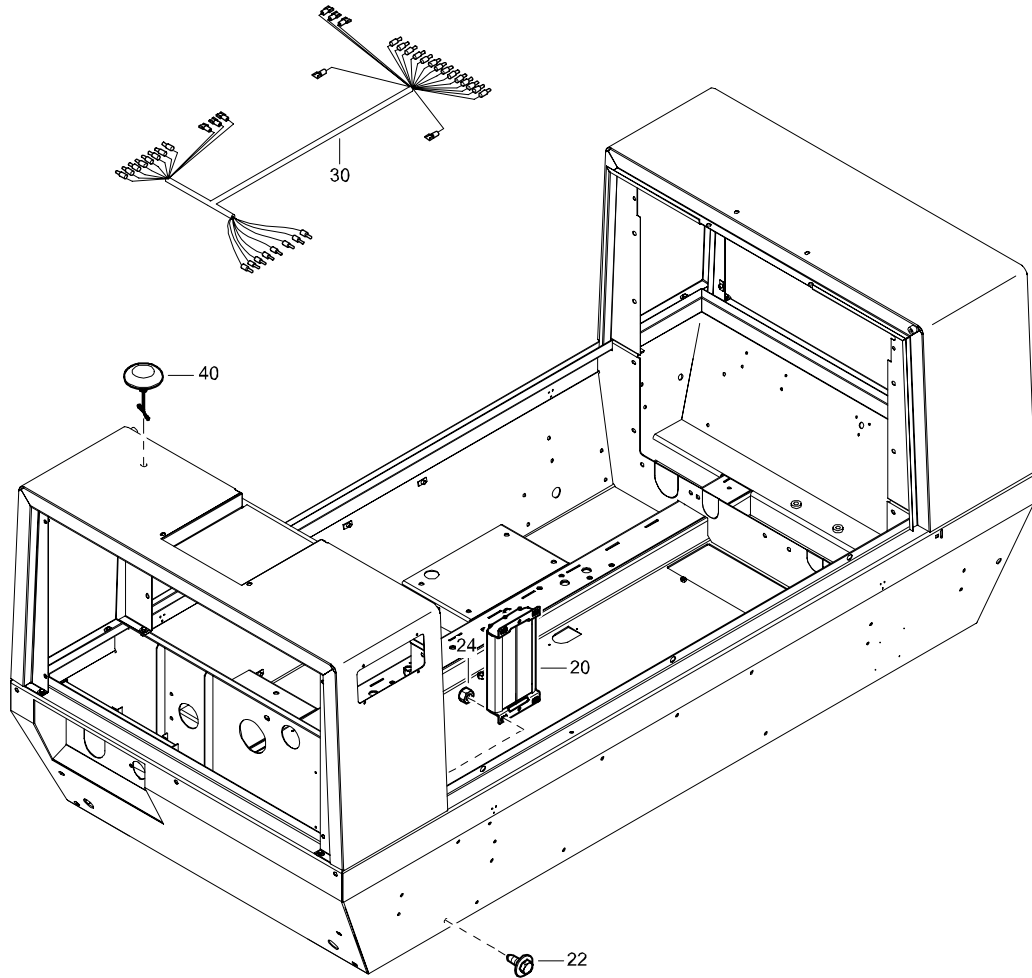

REF	PART NUMBER	DESIGNATION	QTY	REF	PART NUMBER	DESIGNATION	QTY
20	1604 8945 00	COSMOS MODULE	1				
22	1615 5664 00	HEX. HEAD SCREW	4				
24	0266 2110 00	HEXAGON NUT	4				
30	1626 0087 00	WIRING COSMOS	1				
40	1604 7837 00	ANTENNA	1				

# OPTIONS

## TOWBAR AND AXLE FOR COMPRESSOR WITH FIXED TOWBAR & WITHOUT BRAKES

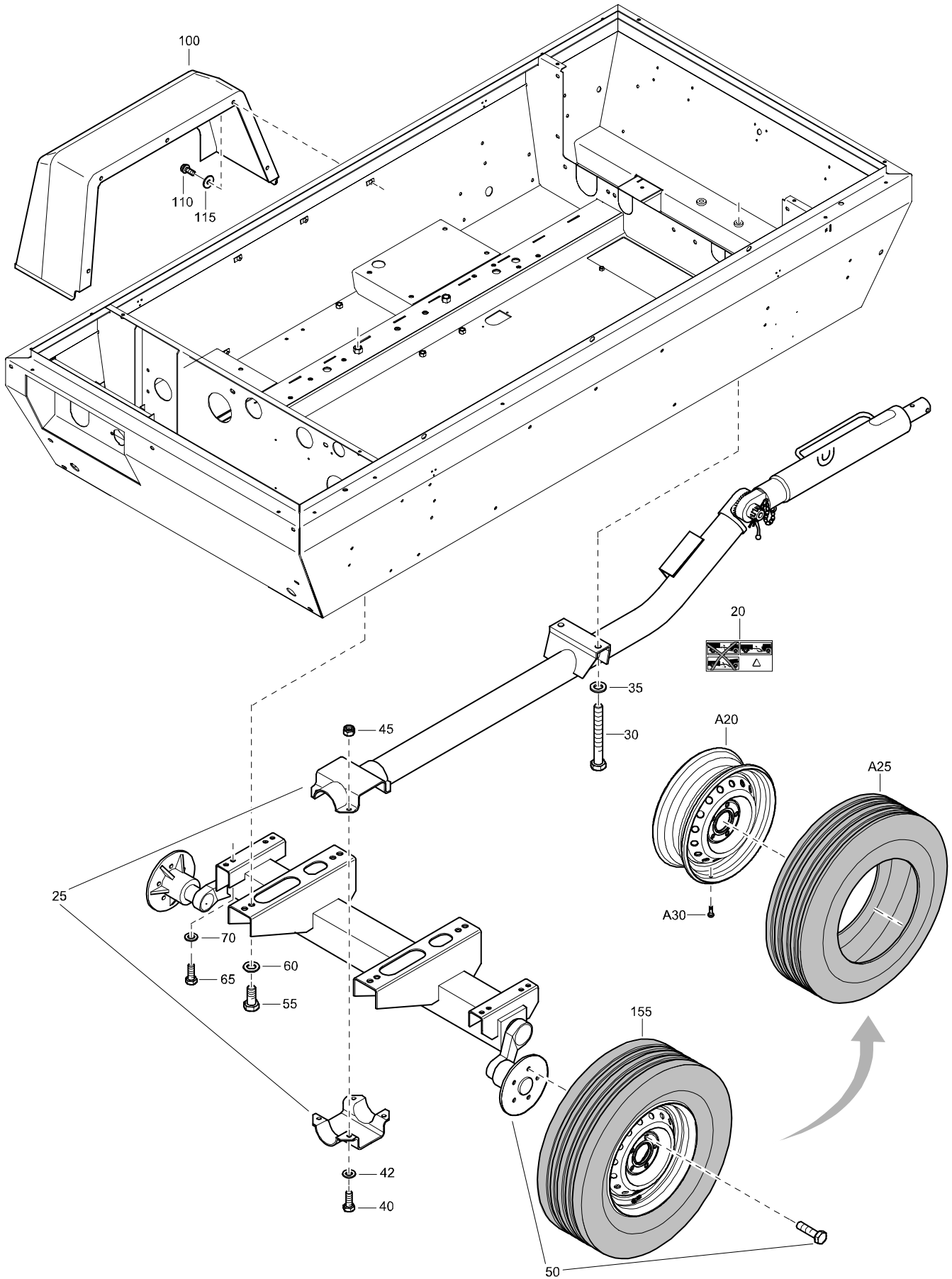

---

# OPTIONS

## TOWBAR AND AXLE FOR COMPRESSOR WITH FIXED TOWBAR & WITHOUT BRAKES

---

REF	PART NUMBER	DESIGNATION	QTY	REF	PART NUMBER	DESIGNATION	QTY
20	1079 9902 00	WARNING LABEL	1				
25	1604 0444 02	TOWBAR (FIXED-NO BRAKES) <a href="#">(For details see page 127)</a>	1				
30	0147 1489 15	HEX. HEAD SCREW	2				
35	0301 2378 00	PLAIN WASHER	2				
40	0147 1401 03	HEX. HEAD SCREW	4				
42	0301 2358 00	PLAIN WASHER	4				
45	0291 1112 00	LOCKNUT	4				
50	1604 0441 02	AXLE (NO BRAKES) <a href="#">(For details see page 125)</a>	1				
55	0147 1958 96	HEX. HEAD SCREW	4				
60	0301 2378 00	PLAIN WASHER	4				
65	0147 1401 15	HEX. HEAD SCREW	4				
70	0301 2358 00	PLAIN WASHER	4				
100	1604 0451 01	MUDGUARD	2				
110	1619 2766 00	HEX. HEAD SCREW	10				
115	0300 8019 00	PLAIN WASHER	10				
155	1604 0260 81	TYRE ASSY	2				
•A20	1626 0260 00	WHEEL	1				
•A25	0538 0400 06	TYRE	1				
•A30	1615 6322 00	VENTIL	1				

# OPTIONS

## TOWBAR AND AXLE FOR COMPRESSOR WITH FIXED TOWBAR & BRAKES

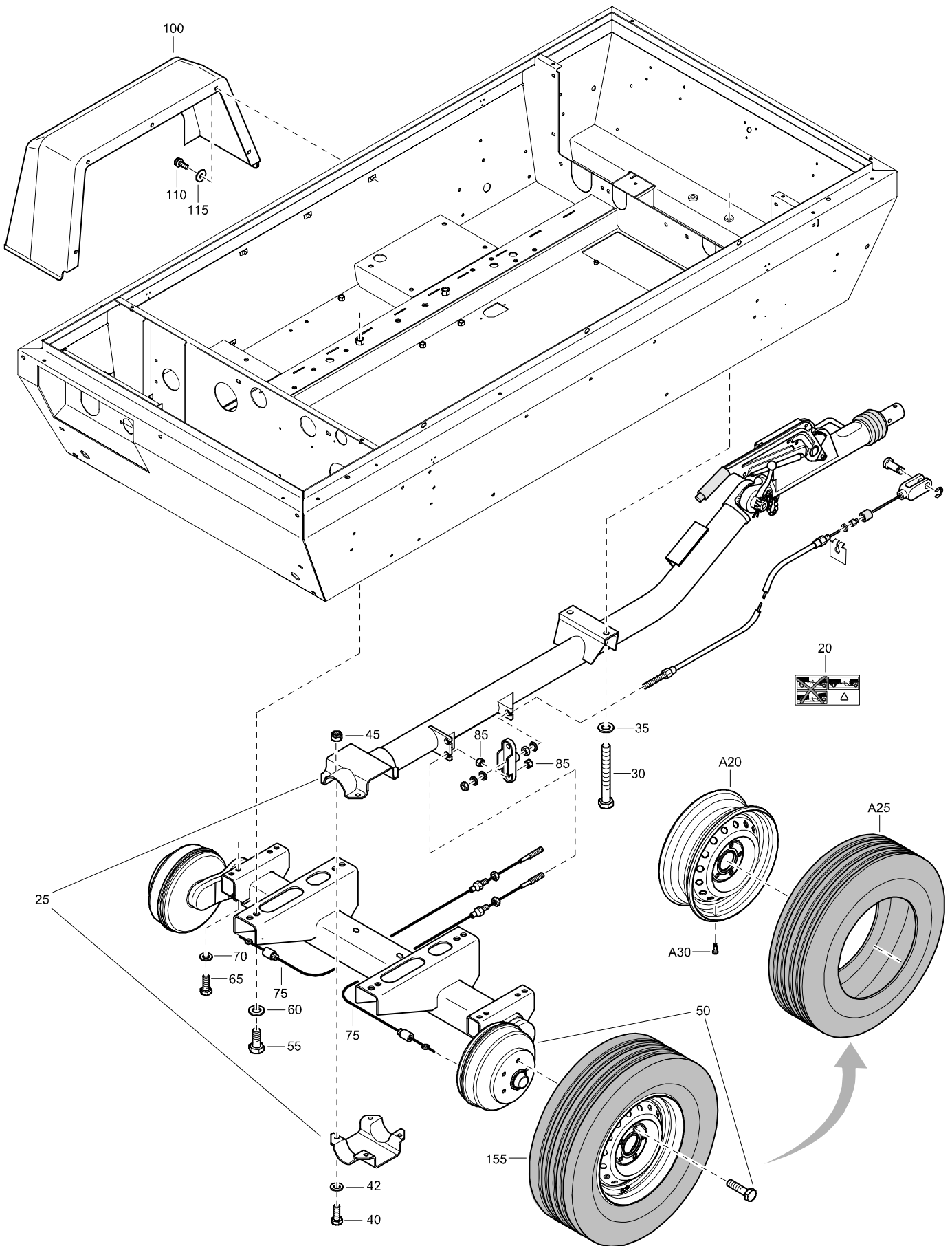



---

# OPTIONS

## TOWBAR AND AXLE FOR COMPRESSOR WITH FIXED TOWBAR & BRAKES

---

REF	PART NUMBER	DESIGNATION	QTY	REF	PART NUMBER	DESIGNATION	QTY
20	1079 9902 00	WARNING LABEL	1				
25	1604 0443 02	TOWBAR (FIXED-BRAKES) <a href="#">(For details see page 126)</a>	1				
30	0147 1489 15	HEX. HEAD SCREW	2				
35	0301 2378 00	PLAIN WASHER	2				
40	0147 1401 03	HEX. HEAD SCREW	4				
42	0301 2358 00	PLAIN WASHER	4				
45	0291 1112 00	LOCKNUT	4				
50	1604 0440 04	AXLE(BRAKES) <a href="#">(For details see page 124)</a>	1				
55	0147 1958 96	HEX. HEAD SCREW	4				
60	0301 2378 00	PLAIN WASHER	4				
65	0147 1401 15	HEX. HEAD SCREW	4				
70	0301 2358 00	PLAIN WASHER	4				
75	1604 0447 00	BRAKE CABLE	2				
85	0266 2110 00	HEXAGON NUT	4				
100	1604 0451 01	MUDGUARD	2				
110	1619 2766 00	HEX. HEAD SCREW	10				
115	0300 8019 00	PLAIN WASHER	10				
155	1604 0260 81	TYRE ASSY	2				
•A20	1626 0260 00	WHEEL	1				
•A25	0538 0400 06	TYRE	1				
•A30	1615 6322 00	VENTIL	1				

# OPTIONS

## TOWBAR AND AXLE FOR COMPRESSOR ADJUSTABLE TOWBAR AND BRAKES

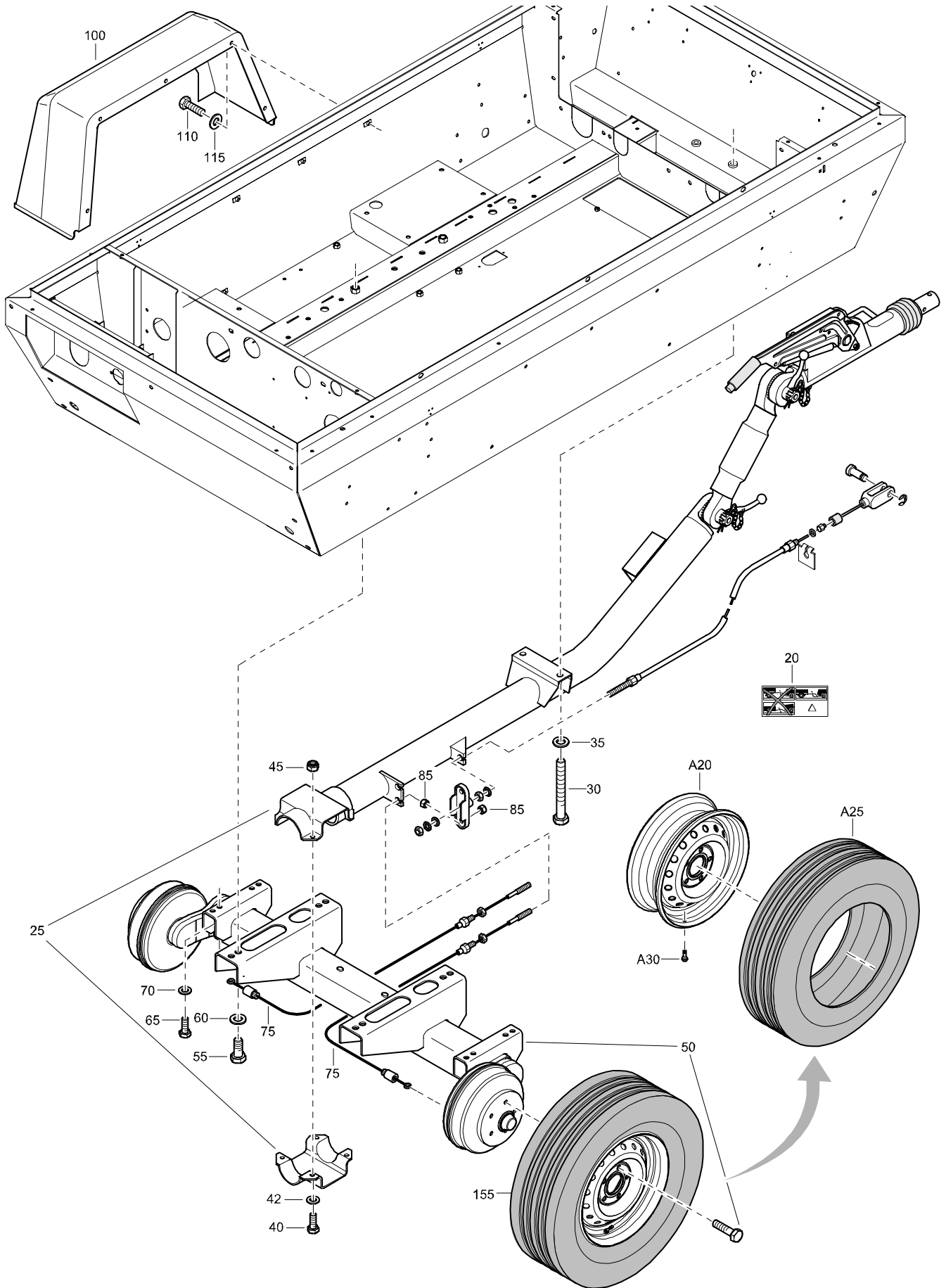

---

# OPTIONS

## TOWBAR AND AXLE FOR COMPRESSOR ADJUSTABLE TOWBAR AND BRAKES

---

REF	PART NUMBER	DESIGNATION	QTY	REF	PART NUMBER	DESIGNATION	QTY
20	1079 9902 00	WARNING LABEL	1				
25	1604 0445 00	TOWBAR	1				
		(For details see page 128)					
30	0147 1489 15	HEX. HEAD SCREW	2				
35	0301 2378 00	PLAIN WASHER	2				
40	0147 1401 03	HEX. HEAD SCREW	4				
42	0301 2358 00	PLAIN WASHER	4				
45	0291 1112 00	LOCKNUT	4				
50	1604 0440 04	AXLE(BRAKES)	1				
		(For details see page 124)					
55	0147 1958 96	HEX. HEAD SCREW	4				
60	0301 2378 00	PLAIN WASHER	4				
65	0147 1401 15	HEX. HEAD SCREW	4				
70	0301 2358 00	PLAIN WASHER	4				
75	1604 0447 00	BRAKE CABLE	2				
85	0266 2110 00	HEXAGON NUT	4				
100	1604 0451 01	MUDGUARD	2				
110	1619 2766 00	HEX. HEAD SCREW	10				
115	0300 8019 00	PLAIN WASHER	10				
155	1604 0260 81	TYRE ASSY	2				
•A20	1626 0260 00	WHEEL	1				
•A25	0538 0400 06	TYRE	1				
•A30	1615 6322 00	VENTIL	1				

# OPTIONS

## TOWBAR ACCESSORIES SUPPORT LEG, JOCKEY WHEEL, SAFETY CHAIN CE

### SUPPORT LEG-WITH BRAKES

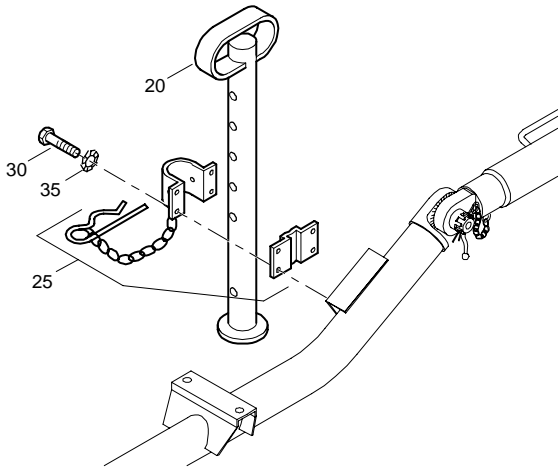

REF	PART NUMBER	DESIGNATION	QTY
20	1615 7752 01	FOOT	1
25	1615 7751 00	CLAMP ASSY	1
30	0147 1363 03	HEX. HEAD SCREW	4
35	0333 3232 00	LOCK WASHER	4

1611 7720 27/02

### JOCKEY WHEEL

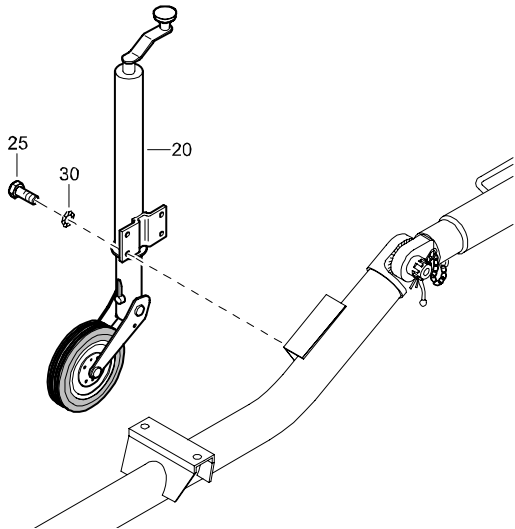

REF	PART NUMBER	DESIGNATION	QTY
20	1615 7769 00	SWIVEL WHEEL	1
25	0147 1362 03	HEXAGON HEAD SCREW	4
30	0333 3232 00	SERRATED LOCKWASHER	4

1611 7721 27/00

### SAFETY CHAIN CE

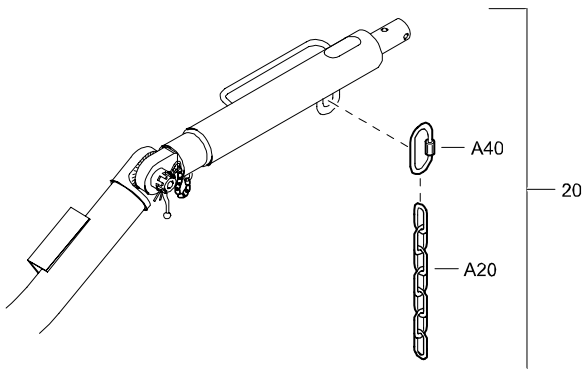

REF	PART NUMBER	DESIGNATION	QTY
20	1604 1575 80	CHAIN ASSY	1
•A20	1604 1575 00	SAFETY CHAIN	1
•A40	1604 1572 03	QUICK COUPLING	2

1611 7722 27/02

---

## OPTIONS

### METAL FILLERNECK FOR FUEL TANK

---

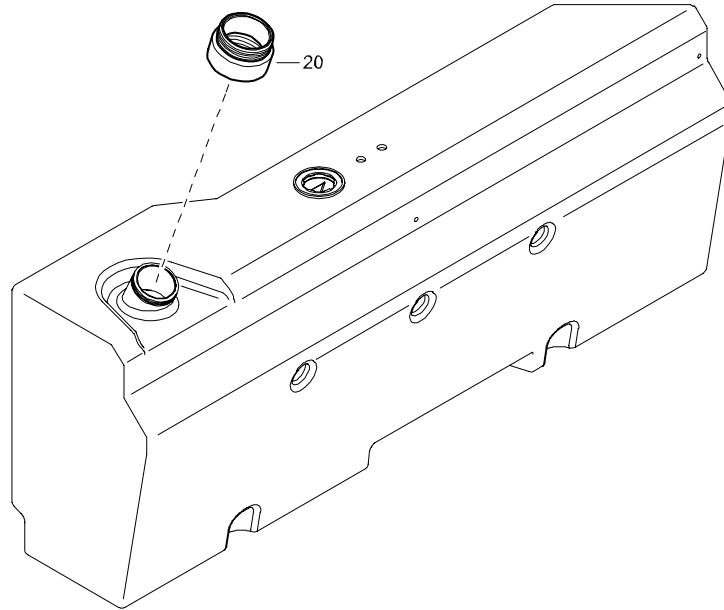

REF	PART NUMBER	DESIGNATION	QTY	REF	PART NUMBER	DESIGNATION	QTY
20	1604 4494 00	CONNECTION NUT FUEL TANK	1				

# OPTIONS

## SPARK ARRESTOR

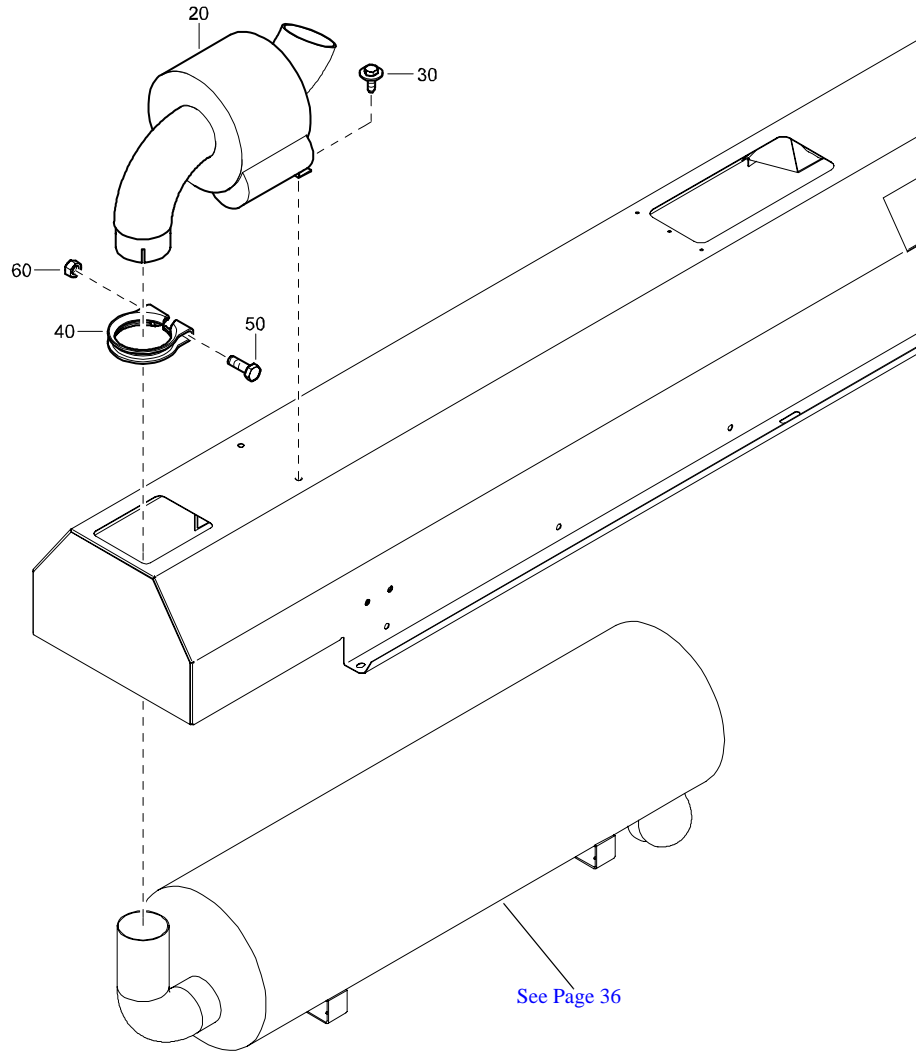

REF	PART NUMBER	DESIGNATION	QTY	REF	PART NUMBER	DESIGNATION	QTY
20	1604 0568 00	SPARK ARRESTOR	1				
30	1615 5664 00	SCRAPER BOLT	2				
40	0346 3001 05	PIPE CLAMP	1				
50	0147 1362 03	HEX. HEAD SCREW	1				
60	0266 2111 00	HEXAGON NUT	1				

---

# OPTIONS

## EXHAUST PIPE

---

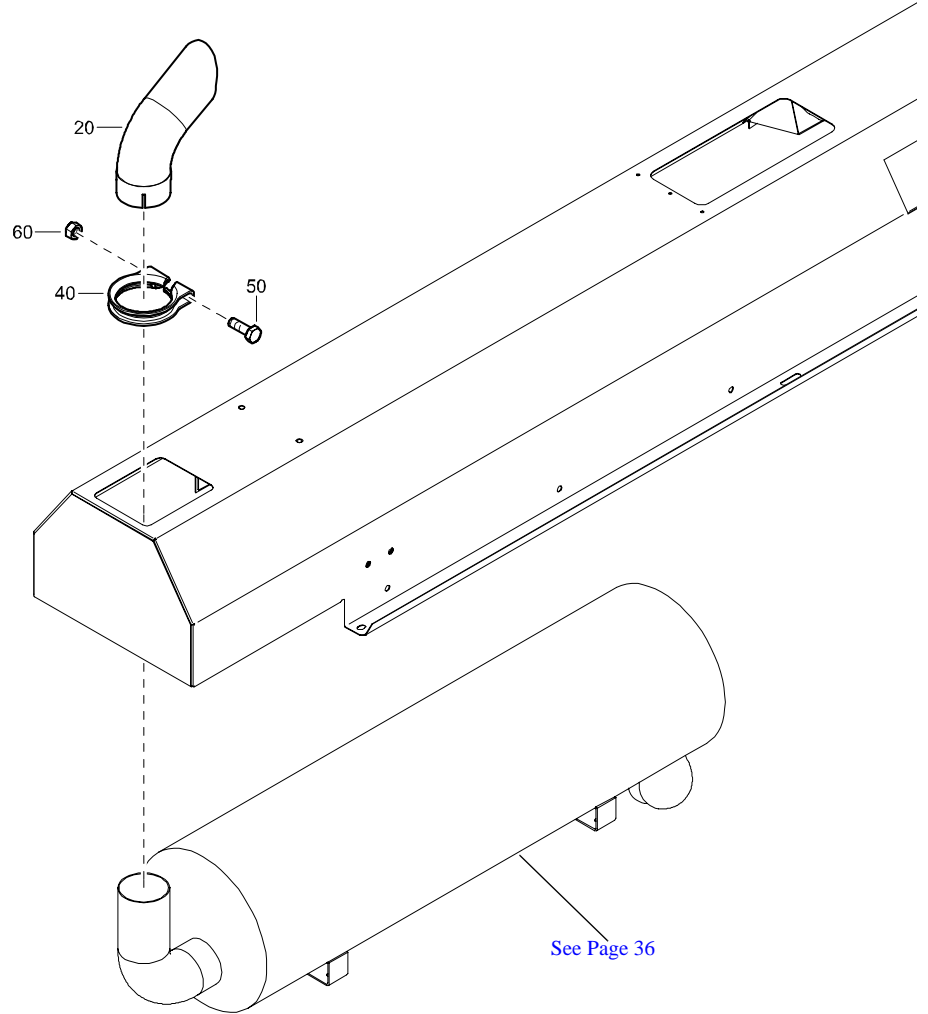

REF	PART NUMBER	DESIGNATION	QTY	REF	PART NUMBER	DESIGNATION	QTY
20	1604 0275 00	EXHAUST PIPE	1				
40	0346 3001 05	PIPE CLAMP	1				
50	0147 1362 03	HEX. HEAD SCREW	1				
60	0266 2111 00	HEXAGON NUT	1				

# OPTION

## PRESSURE GAUGE

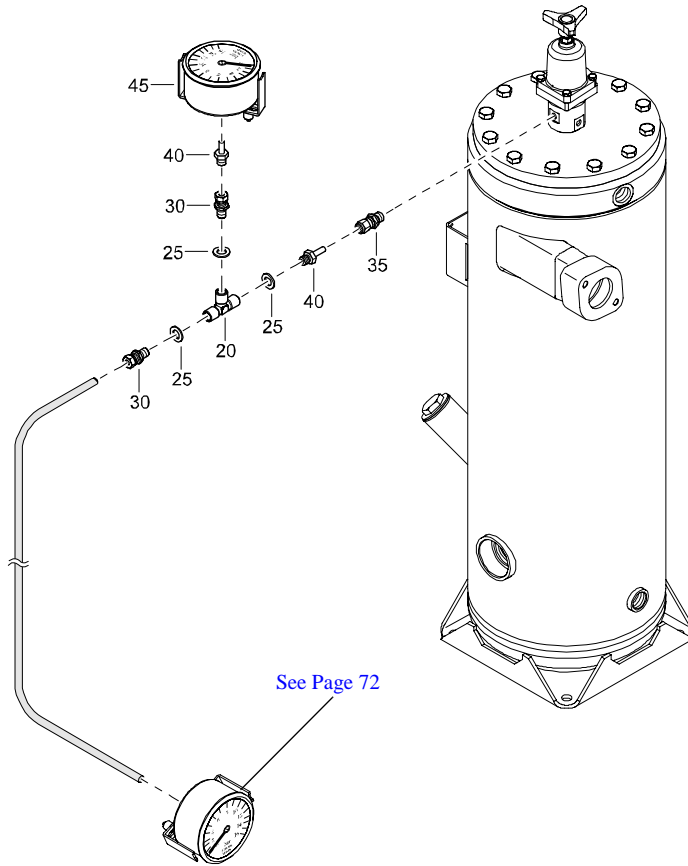

See Page 72

REF	PART NUMBER	DESIGNATION	QTY	REF	PART NUMBER	DESIGNATION	QTY
20	1503 2566 01	TEE	1				
25	0653 1046 00	FLAT GASKET	3				
30	0582 1200 05	STRAIGHT PIPE COUPLING	2				
35	0584 0310 01	STRAIGHT PIPE COUPLING	1				
40	0580 0013 29	STRAIGHT PIPE-COUPLING	2				
45	1615 7264 00	PRESSURE GAUGE	1				



---

# OPTIONS

## ADAPTER FOR ROAD LIGHT SYSTEM

---

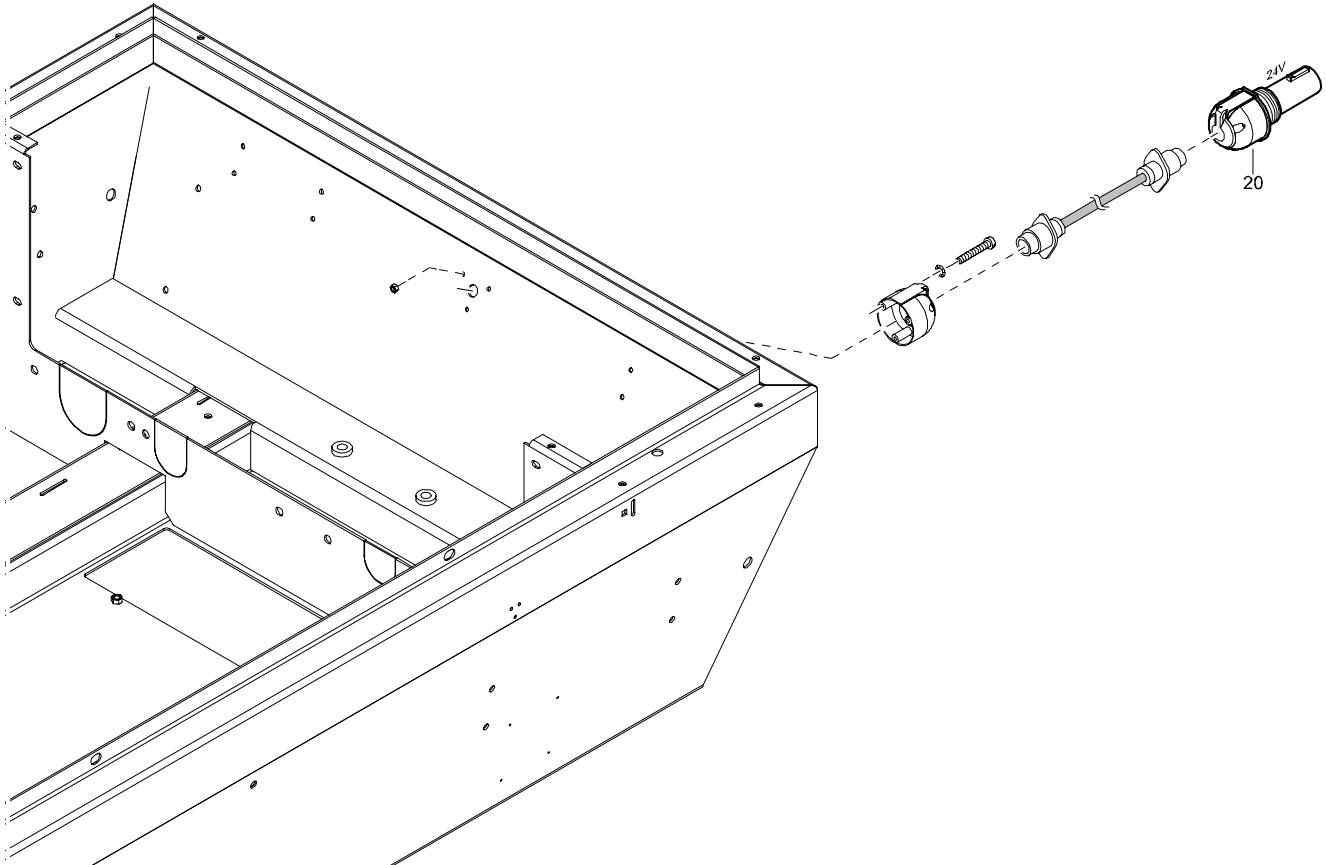

REF	PART NUMBER	DESIGNATION	QTY	REF	PART NUMBER	DESIGNATION	QTY
20	1604 5313 00	ADAPTER 24V RS	1				

# OPTIONS

## ROAD LIGHT SYSTEM

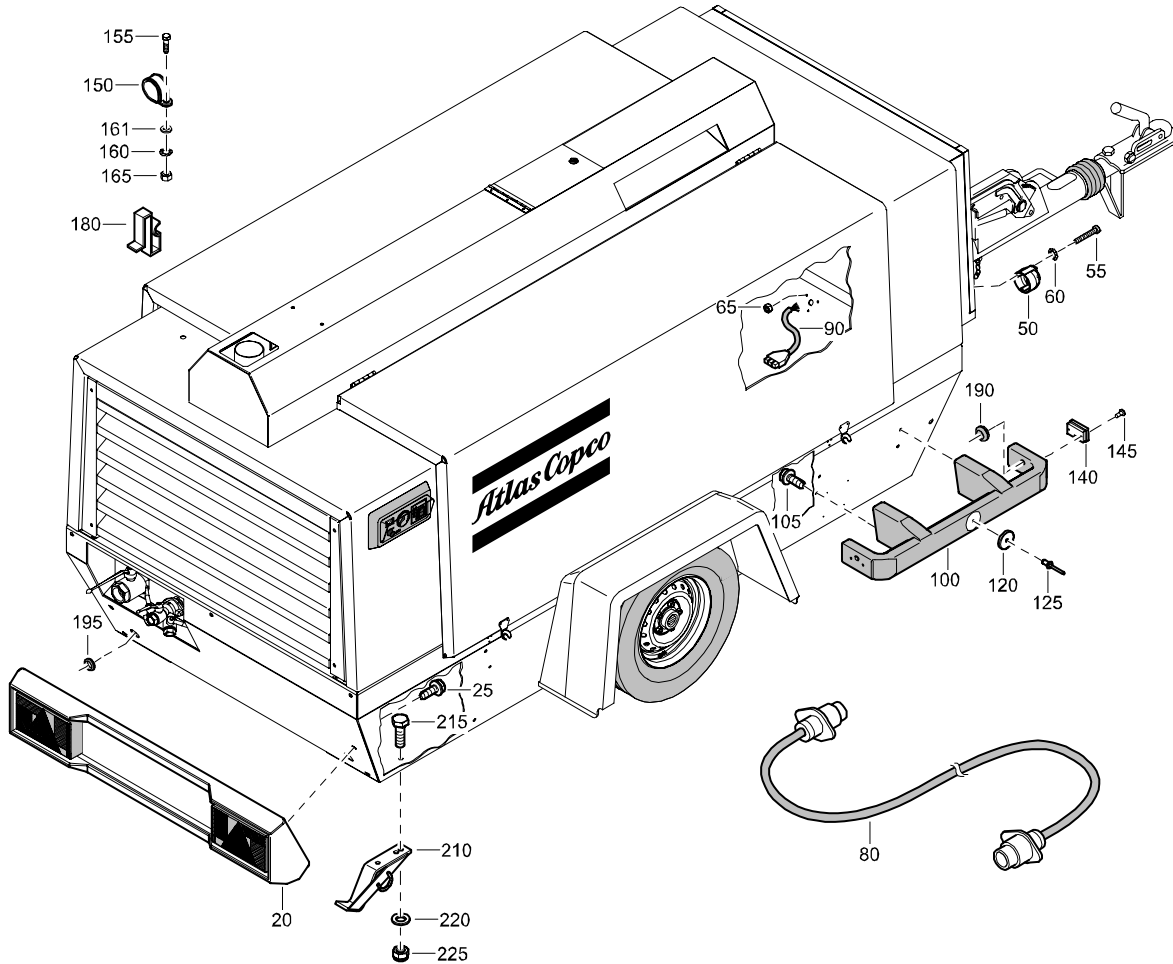

REF	PART NUMBER	DESIGNATION	QTY	REF	PART NUMBER	DESIGNATION	QTY
20	1604 0570 81	PANEL ASSY (For details see page 123)	1	180	1088 0830 09	CABLE CLAMP	4
25	1619 2766 00	BOLT	4	190	0698 0150 00	GROMMET	2
50	1089 0291 02	APPLIANCE INLET	1	195	1088 0801 40	GROMMET	1
55	0160 6066 00	SLOTTED SCREW	3	210	1202 7695 01	BRACKET	2
60	0333 3215 00	LOCK WASHER	3	215	0147 1401 03	HEX. HEAD SCREW	4
65	0266 2107 00	HEXAGON NUT	3	220	0301 2358 00	PLAIN WASHER	4
80	1616 0864 00	CABLE	1	225	0291 1112 00	LOCKNUT	4
90	1604 0575 00	WIRE HARNESS	1				
100	1604 0571 00	PROTECTION	2				
105	1619 2766 00	BOLT	8				
120	1615 5520 00	REFLECTOR	4				
125	0129 3174 01	BLIND RIVET	2				
140	1604 0578 00	FRONT MARKER	2				
145	0226 3343 17	TAPPING SCREW	4				
150	1613 0801 00	CLAMP	2				
155	0147 1247 03	HEX. HEAD SCREW	2				
160	0333 3220 00	LOCK WASHER	2				
161	0301 2321 00	PLAIN WASHER	2				
165	0266 2108 00	HEXAGON NUT	2				

# OPTIONS

## ROAD LIGHT SYSTEM FRANCE

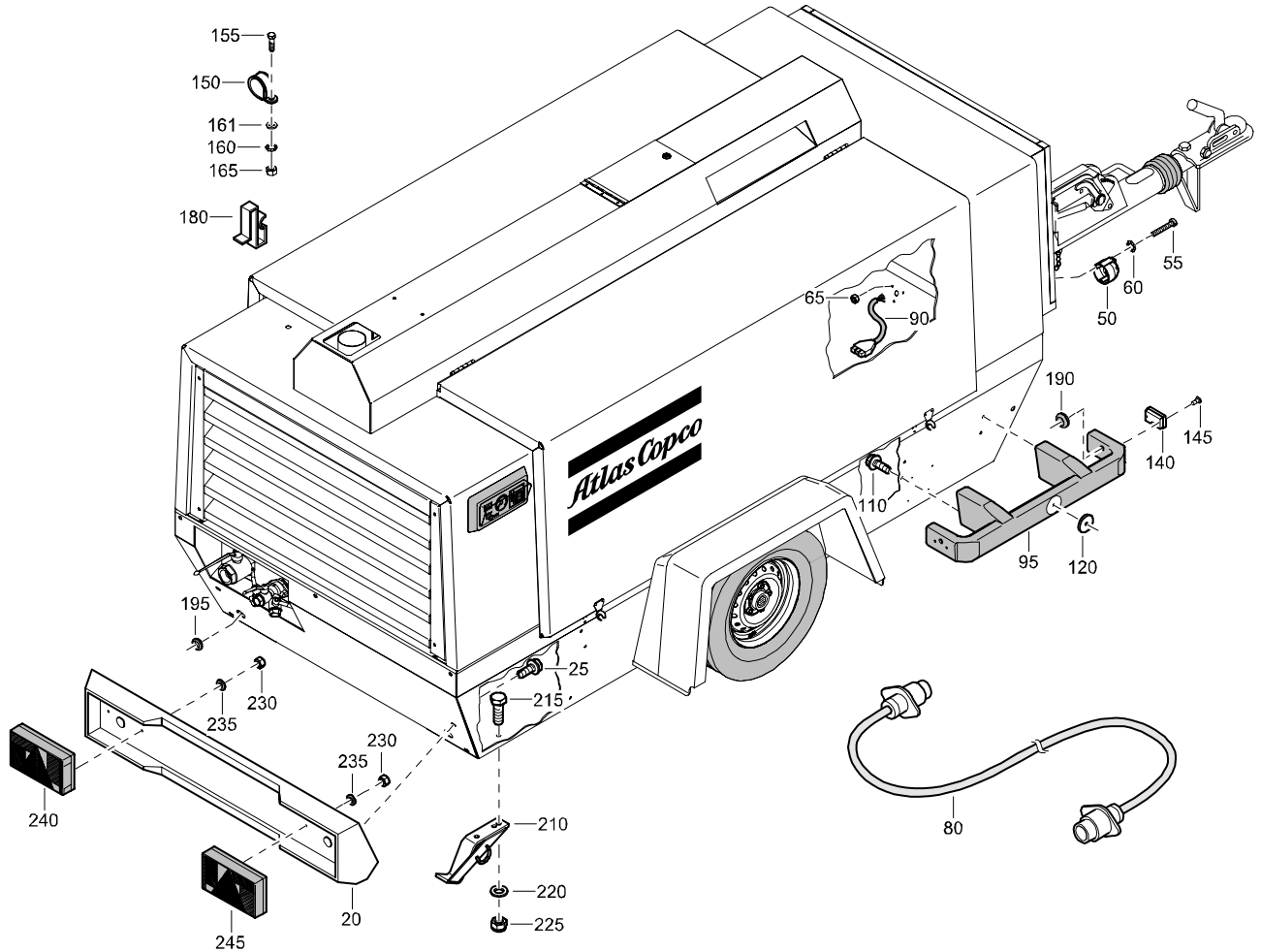

REF	PART NUMBER	DESIGNATION	QTY	REF	PART NUMBER	DESIGNATION	QTY
20	1604 4748 01	BUMPER BAR	1	195	1088 0801 40	GROMMET	2
25	1619 2766 00	BOLT	4	210	1202 7695 01	BRACKET	2
50	1089 0291 02	APPLIANCE INLET	1	215	0147 1401 03	HEX. HEAD SCREW	4
55	0160 6066 00	SLOTTED SCREW	3	220	0301 2358 00	PLAIN WASHER	4
60	0333 3215 00	LOCK WASHER	3	225	0291 1112 00	LOCKNUT	4
65	0266 2107 00	HEXAGON NUT	3	230	0266 2108 00	HEXAGON NUT	4
80	1616 0864 00	CABLE	1	235	0301 2321 00	PLAIN WASHER	4
90	1604 0575 00	WIRE HARNESS	1	240	1604 1742 01	LIGHT LH	1
95	1604 0571 00	PROTECTION	4	245	1604 0577 01	LIGHT RH	1
110	1619 2766 00	BOLT	16				
120	1615 5520 00	REFLECTOR	4				
140	1604 0578 00	FRONT MARKER	2				
145	0226 3343 17	TAPPING SCREW	4				
150	1613 0801 00	CLAMP	2				
155	0147 1247 03	HEX. HEAD SCREW	2				
160	0333 3220 00	LOCK WASHER	2				
161	0301 2321 00	PLAIN WASHER	2				
165	0266 2108 00	HEXAGON NUT	2				
180	1088 0830 09	CABLE CLAMP	4				
190	0698 0150 00	GROMMET	2				

# OPTIONS

## SUPPORT FOR SUPPORT MOUNTED COMPRESSOR

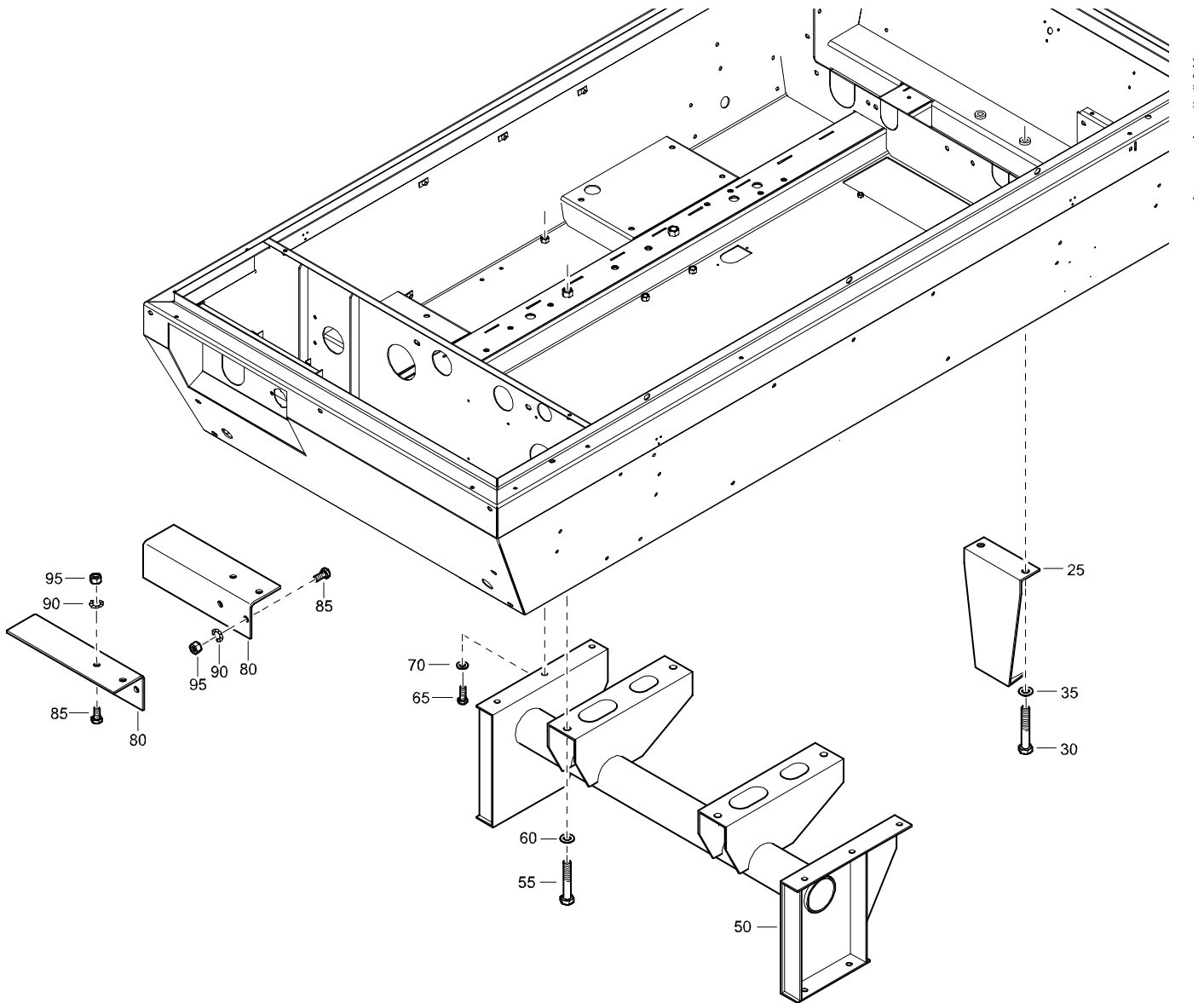

REF	PART NUMBER	DESIGNATION	QTY	REF	PART NUMBER	DESIGNATION	QTY
25	1604 0555 00	SUPPORT	1				
30	0147 1489 15	HEX. HEAD SCREW	1				
35	0301 2378 00	PLAIN WASHER	2				
50	1604 0556 05	SUPPORT	1				
55	0147 1958 96	HEX. HEAD SCREW	4				
60	0301 2378 00	PLAIN WASHER	4				
65	0147 1401 15	HEX. HEAD SCREW	4				
70	0301 2358 00	PLAIN WASHER	4				
80	1604 1433 00	SUPPORT	2				
85	0147 1400 03	HEX. HEAD SCREW	4				
90	0333 3237 00	LOCK WASHER	4				
95	0266 2112 00	HEXAGON NUT	4				

---

# OPTIONS

## SAFETY CARTRIDGE

---

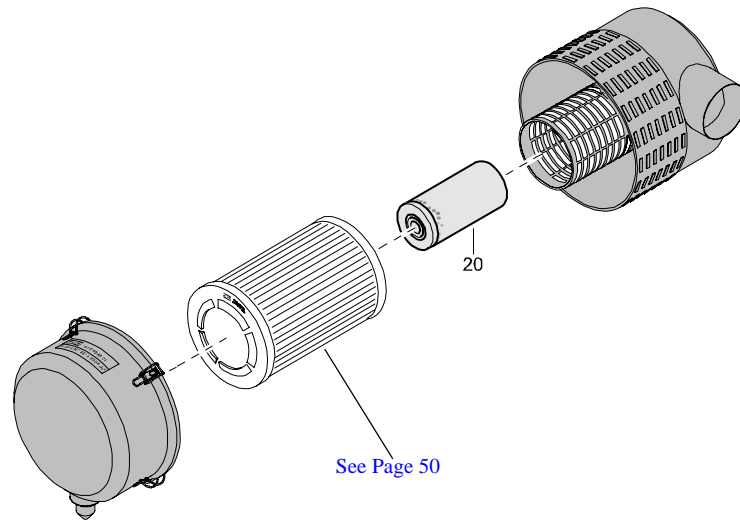

REF	PART NUMBER	DESIGNATION	QTY	REF	PART NUMBER	DESIGNATION	QTY
20	2914 9311 00	SAFETY CARTRIDGE 15MÜ	2				

# OPTIONS

## SKID FOR SKID MOUNTED COMPRESSOR

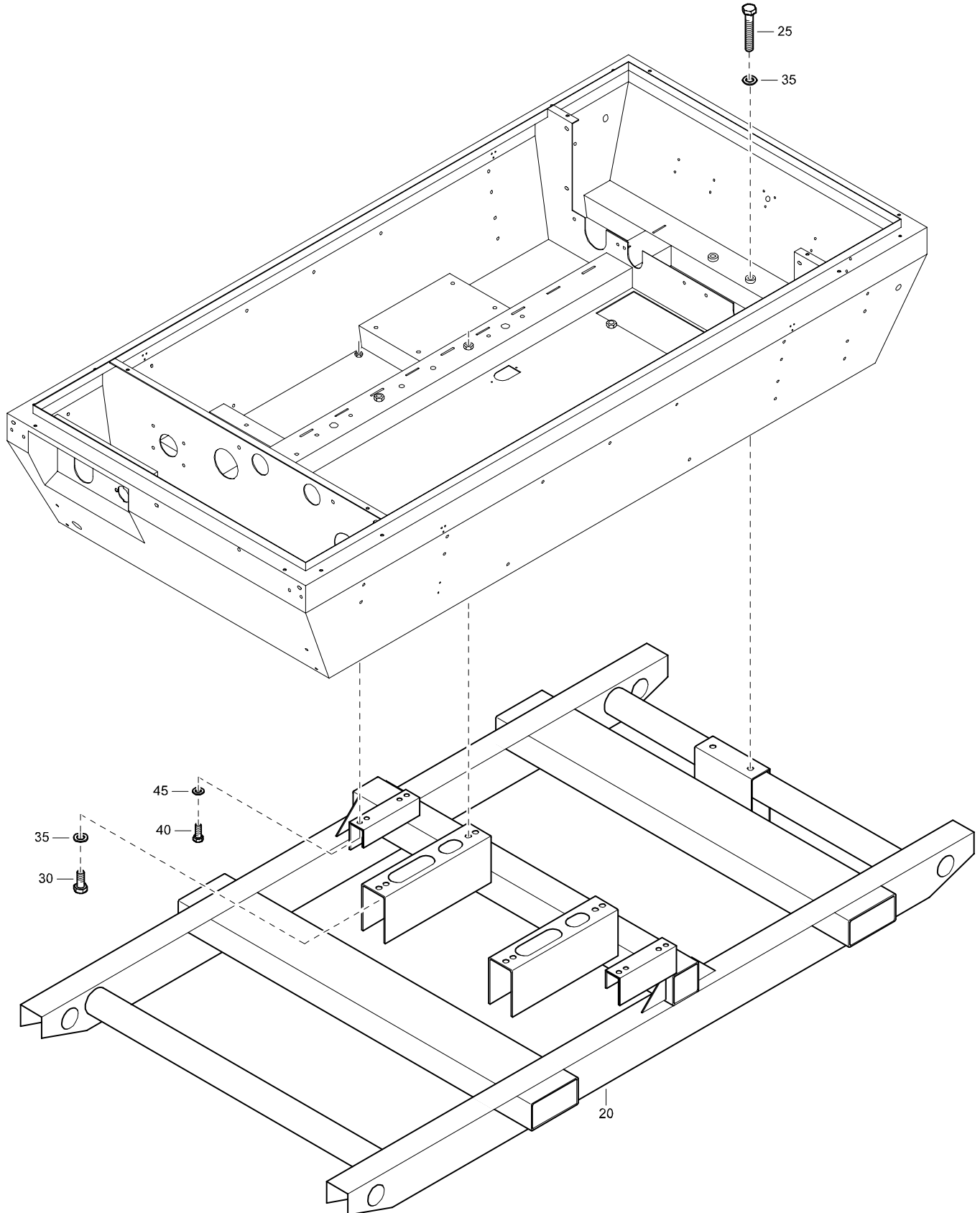

---

# OPTIONS

## SKID FOR SKID MOUNTED COMPRESSOR

---

REF	PART NUMBER	DESIGNATION	QTY	REF	PART NUMBER	DESIGNATION	QTY
20	1604 8201 01	SKID	1				
25	0147 1489 15	HEX. HEAD SCREW	2				
30	0147 1958 96	HEX. HEAD SCREW	4				
35	0301 2378 00	PLAIN WASHER	6				
40	0147 1401 15	HEX. HEAD SCREW	4				
45	0301 2358 00	PLAIN WASHER	4				





---

# OPTIONS

## AFTERCOOLER WITH WATERSEPERATOR

---

REF	PART NUMBER	DESIGNATION	QTY	REF	PART NUMBER	DESIGNATION	QTY
20	1604 0520 01	CONNECTION	1				
30	1604 0526 00	BRACKET	2				
35	1604 0527 00	BRACKET	2				
40	0147 1320 03	HEX. HEAD SCREW	8				
45	0333 3227 00	LOCK WASHER	8				
50	1604 0528 01	AFTERCOOLER	1				
55	0147 1323 03	HEX. HEAD SCREW	4				
60	0301 2335 00	PLAIN WASHER	8				
65	0291 1110 00	LOCKNUT	4				
68	0653 1062 00	FLAT GASKET	1				
70	0803 5012 11	SILENCER	1				
72	1615 8619 01	COUPLING	1				
74	1615 8620 00	RESTRICTOR	1				
76	0070 6002 05	PLASTIC TUBE	AR				
85	0571 0035 41	HEXAGON NIPPLE	2				
90	0661 1062 00	SEALING WASHER	2				
95	1604 0529 02	PIPE AFTERCOOLER	1				
100	0571 0035 41	HEXAGON NIPPLE	2				
105	0661 1062 00	SEALING WASHER	2				
110	1604 0533 00	BRACKET	2				
120	1604 0530 01	WSD-FILTER	1				
123	0653 1062 00	FLAT GASKET	1				
125	0803 5012 11	SILENCER	1				
130	1615 8619 01	COUPLING	1				
132	1615 8620 00	RESTRICTOR	1				
134	0070 6002 05	PLASTIC TUBE	AR				
160	0147 1360 03	HEX. HEAD SCREW	4				
165	0333 3232 00	LOCK WASHER	4				
170	0301 2344 00	PLAIN WASHER	4				
175	0266 2111 00	HEXAGON NUT	4				
180	1615 5664 00	HEX. HEAD SCREW	4				
190	1604 0534 00	BRACKET	1				
200	1615 5664 00	HEX. HEAD SCREW	2				
205	1615 5664 00	HEX. HEAD SCREW	2				
215	1604 0536 00	PIPE	1				
230	0571 0035 41	HEXAGON NIPPLE	1				
235	0661 1062 00	SEALING WASHER	1				
250	0686 3716 07	HEXAGON PLUG	2				
255	0661 1049 00	SEALING WASHER	2				

# OPTIONS

## AFTERCOOLER WITH WATERSEPARATOR & PD FILTER

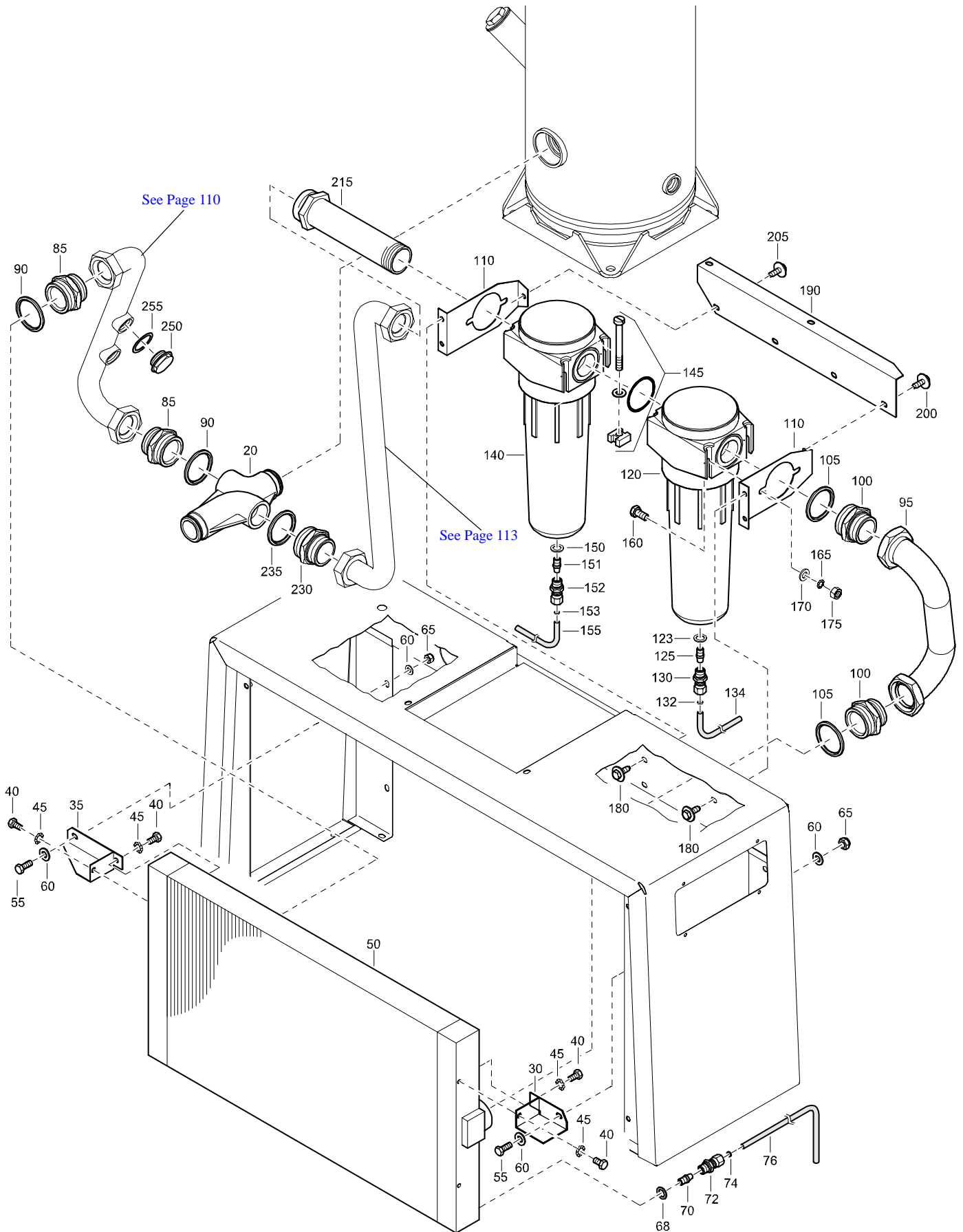

---

# OPTIONS

## AFTERCOOLER WITH WATERSEPERATOR & PD FILTER

---

REF	PART NUMBER	DESIGNATION	QTY	REF	PART NUMBER	DESIGNATION	QTY
20	1604 0520 01	CONNECTION	1				
30	1604 0526 00	BRACKET	2				
35	1604 0527 00	BRACKET	2				
40	0147 1320 03	HEX. HEAD SCREW	8				
45	0333 3227 00	LOCK WASHER	8				
50	1604 0528 01	AFTERCOOLER	1				
55	0147 1323 03	HEX. HEAD SCREW	4				
60	0301 2335 00	PLAIN WASHER	8				
65	0291 1110 00	LOCKNUT	4				
68	0653 1062 00	FLAT GASKET	1				
70	0803 5012 11	SILENCER	1				
72	1615 8619 01	COUPLING	1				
74	1615 8620 00	RESTRICTOR	1				
76	0070 6002 05	PLASTIC TUBE	AR				
85	0571 0035 41	HEXAGON NIPPLE	2				
90	0661 1062 00	SEALING WASHER	2				
95	1604 0529 02	PIPE AFTERCOOLER	1				
100	0571 0035 41	HEXAGON NIPPLE	2				
105	0661 1062 00	SEALING WASHER	2				
110	1604 0533 00	BRACKET	2				
120	1604 0530 01	WSD-FILTER	1				
123	0653 1062 00	FLAT GASKET	1				
125	0803 5012 11	SILENCER	1				
130	1615 8619 01	COUPLING	1				
132	1615 8620 00	RESTRICTOR	1				
134	0070 6002 05	PLASTIC TUBE	AR				
140	1604 0535 01	PD-FILTER	1				
145	8092 2102 70	SERIAL CONNECT SET	1				
150	0653 1062 00	FLAT GASKET	1				
151	0803 5012 11	SILENCER	1				
152	1615 8619 01	COUPLING	1				
153	1615 8620 00	RESTRICTOR	1				
155	0070 6002 05	PLASTIC TUBE	AR				
160	0147 1360 03	HEX. HEAD SCREW	4				
165	0333 3232 00	LOCK WASHER	4				
170	0301 2344 00	PLAIN WASHER	4				
175	0266 2111 00	HEXAGON NUT	4				
180	1615 5664 00	HEX. HEAD SCREW	4				
190	1604 0534 00	BRACKET	1				
200	1615 5664 00	HEX. HEAD SCREW	2				
205	1615 5664 00	HEX. HEAD SCREW	2				
215	1604 0538 00	PIPE	1				
230	0571 0035 41	HEXAGON NIPPLE	1				
235	0661 1062 00	SEALING WASHER	1				
250	0686 3716 07	HEXAGON PLUG	2				
255	0661 1049 00	SEALING WASHER	2				

# OPTIONS

## AFTERCOOLER WITH WATERSEPARATOR & PD-QD FILTER

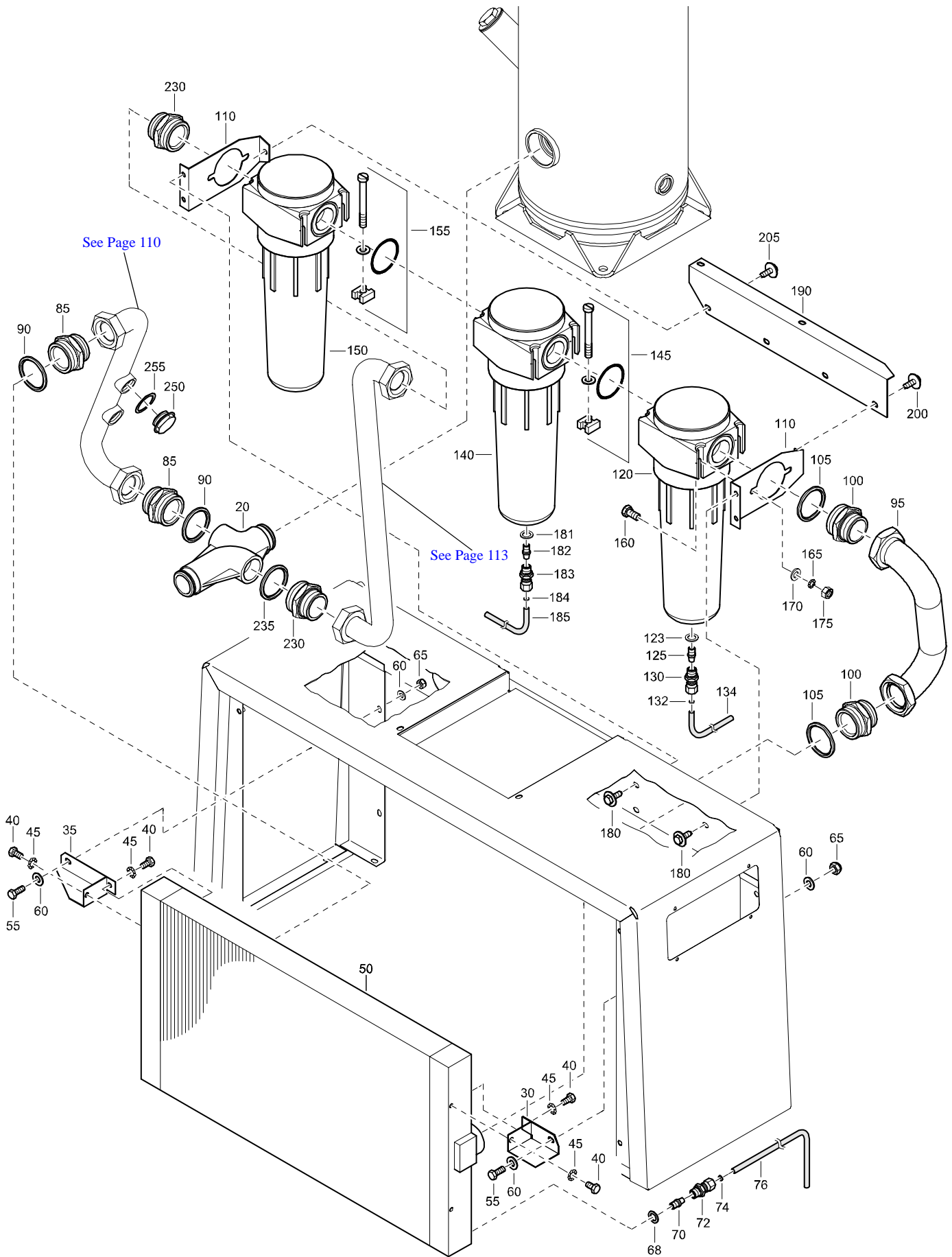

---

# OPTIONS

## AFTERCOOLER WITH WATERSEPERATOR & PD-QD FILTER

---

REF	PART NUMBER	DESIGNATION	QTY	REF	PART NUMBER	DESIGNATION	QTY
20	1604 0520 01	CONNECTION	1				
30	1604 0526 00	BRACKET	2				
35	1604 0527 00	BRACKET	2				
40	0147 1320 03	HEX. HEAD SCREW	8				
45	0333 3227 00	LOCK WASHER	8				
50	1604 0528 01	AFTERCOOLER	1				
55	0147 1323 03	HEX. HEAD SCREW	4				
60	0301 2335 00	PLAIN WASHER	8				
65	0291 1110 00	LOCKNUT	4				
68	0653 1062 00	FLAT GASKET	1				
70	0803 5012 11	SILENCER	1				
72	1615 8619 01	COUPLING	1				
74	1615 8620 00	RESTRICTOR	1				
76	0070 6002 05	PLASTIC TUBE	AR				
85	0571 0035 41	HEXAGON NIPPLE	2				
90	0661 1062 00	SEALING WASHER	2				
95	1604 0529 02	PIPE AFTERCOOLER	1				
100	0571 0035 41	HEXAGON NIPPLE	2				
105	0661 1062 00	SEALING WASHER	2				
110	1604 0533 00	BRACKET	2				
120	1604 0530 01	WSD-FILTER	1				
123	0653 1062 00	FLAT GASKET	1				
125	0803 5012 11	SILENCER	1				
130	1615 8619 01	COUPLING	1				
132	1615 8620 00	RESTRICTOR	1				
134	0070 6002 05	PLASTIC TUBE	AR				
140	1604 0535 01	PD-FILTER	1				
145	8092 2102 70	SERIAL CONNECT SET	1				
150	1604 0532 01	QD-FILTER	1				
155	8092 2102 70	SERIAL CONNECT SET	1				
160	0147 1360 03	HEX. HEAD SCREW	4				
165	0333 3232 00	LOCK WASHER	4				
170	0301 2344 00	PLAIN WASHER	4				
175	0266 2111 00	HEXAGON NUT	4				
180	1615 5664 00	HEX. HEAD SCREW	4				
181	0653 1062 00	FLAT GASKET	1				
182	0803 5012 11	SILENCER	1				
183	1615 8619 01	COUPLING	1				
184	1615 8620 00	RESTRICTOR	1				
185	0070 6002 05	PLASTIC TUBE	AR				
190	1604 0534 00	BRACKET	1				
200	1615 5664 00	HEX. HEAD SCREW	2				
205	1615 5664 00	HEX. HEAD SCREW	2				
230	0571 0035 41	HEXAGON NIPPLE	2				
235	0661 1062 00	SEALING WASHER	1				
250	0686 3716 07	HEXAGON PLUG	2				
255	0661 1049 00	SEALING WASHER	2				

---

# OPTIONS

## PIPE FOR COMPRESSOR WITHOUT AFTERCOOLER BY-PASS

---

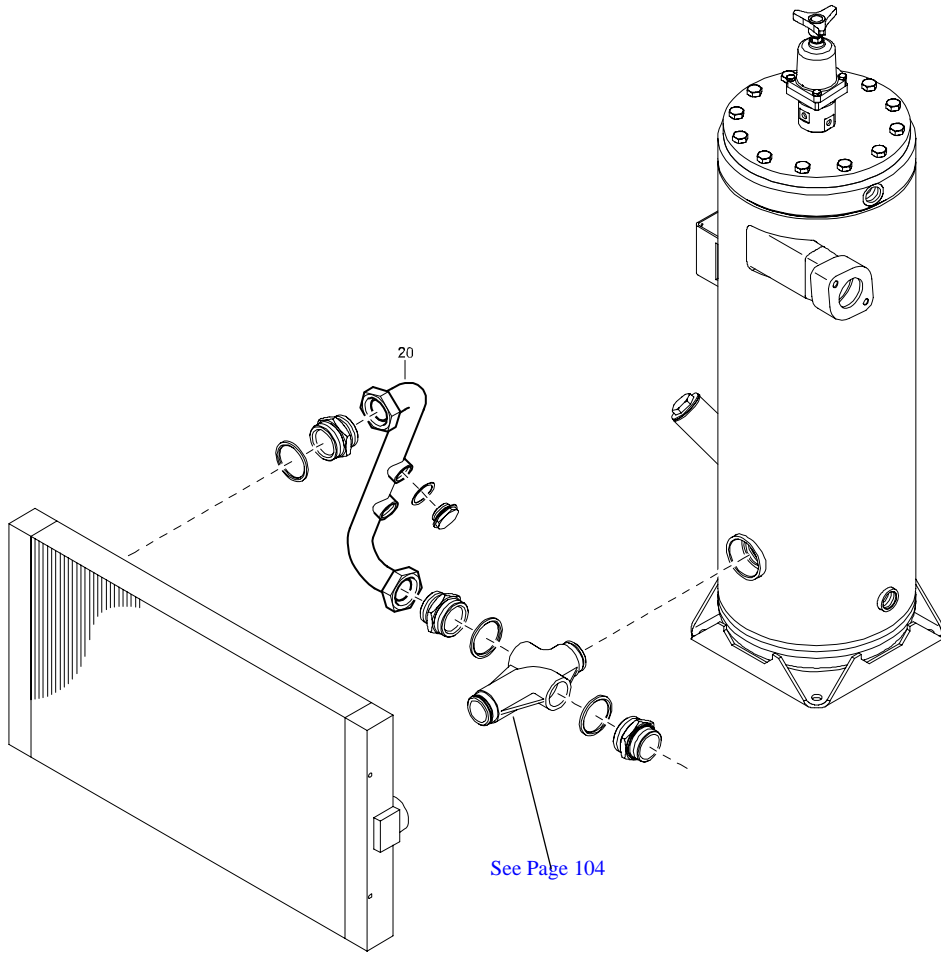

REF	PART NUMBER	DESIGNATION	QTY	REF	PART NUMBER	DESIGNATION	QTY
20	1604 0525 03	PIPE	1				

# OPTIONS

## LUBRICATOR

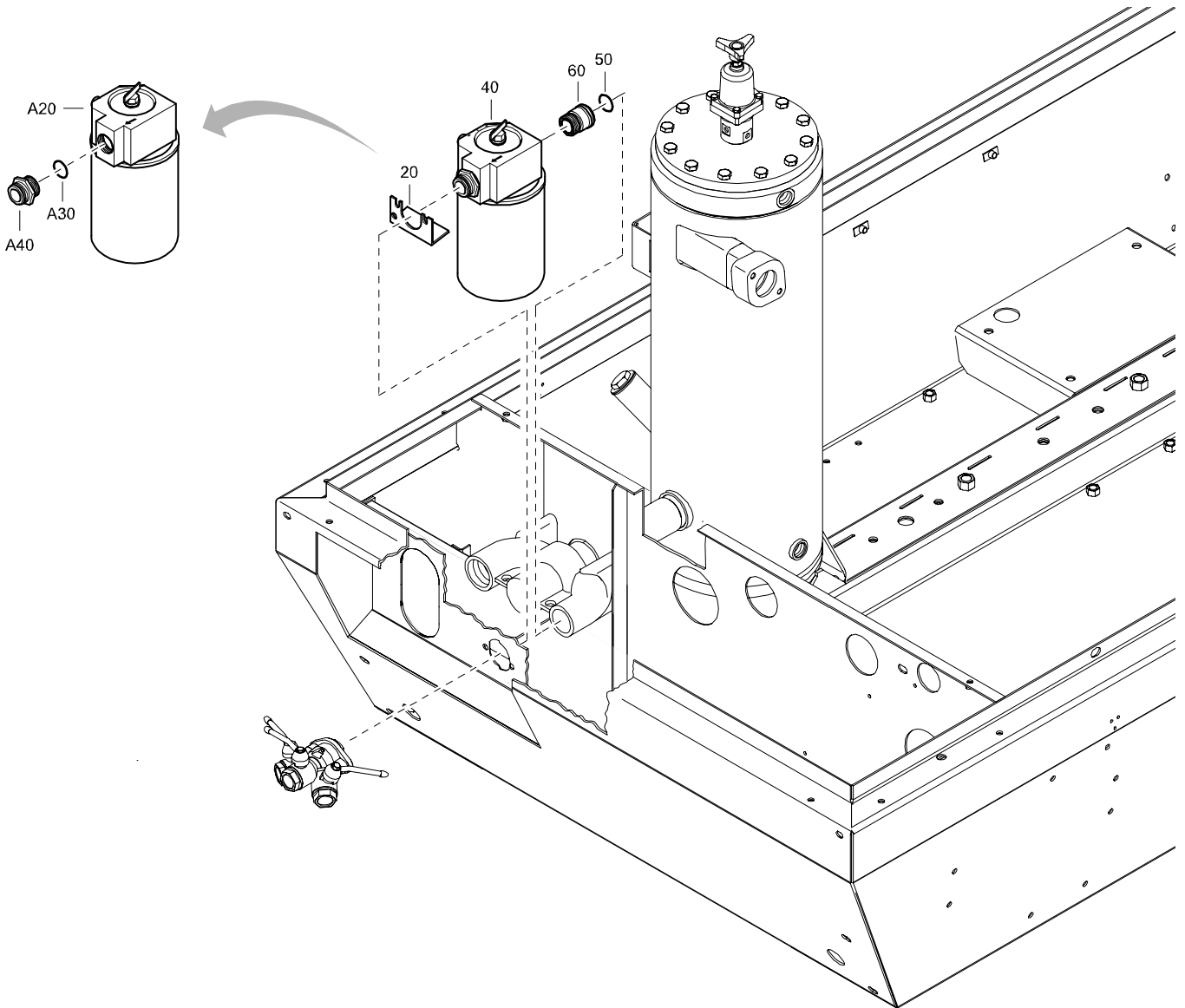

REF	PART NUMBER	DESIGNATION	QTY	REF	PART NUMBER	DESIGNATION	QTY
20	1615 8635 00	BRACKET	1				
40	1604 0290 80	LUBRICATOR ASSEMBLY	1				
•A20	1604 0290 00	LUBRICATOR	1				
•A30	0663 2108 20	O-RING	1				
•A40	1604 0557 00	NIPPLE	1				
50	0663 2108 20	O-RING	1				
60	1604 0558 00	NIPPLE	1				

# OPTIONS

## PIPES AND VALVE FOR PARTIAL AFTERCOOLER BY-PASS

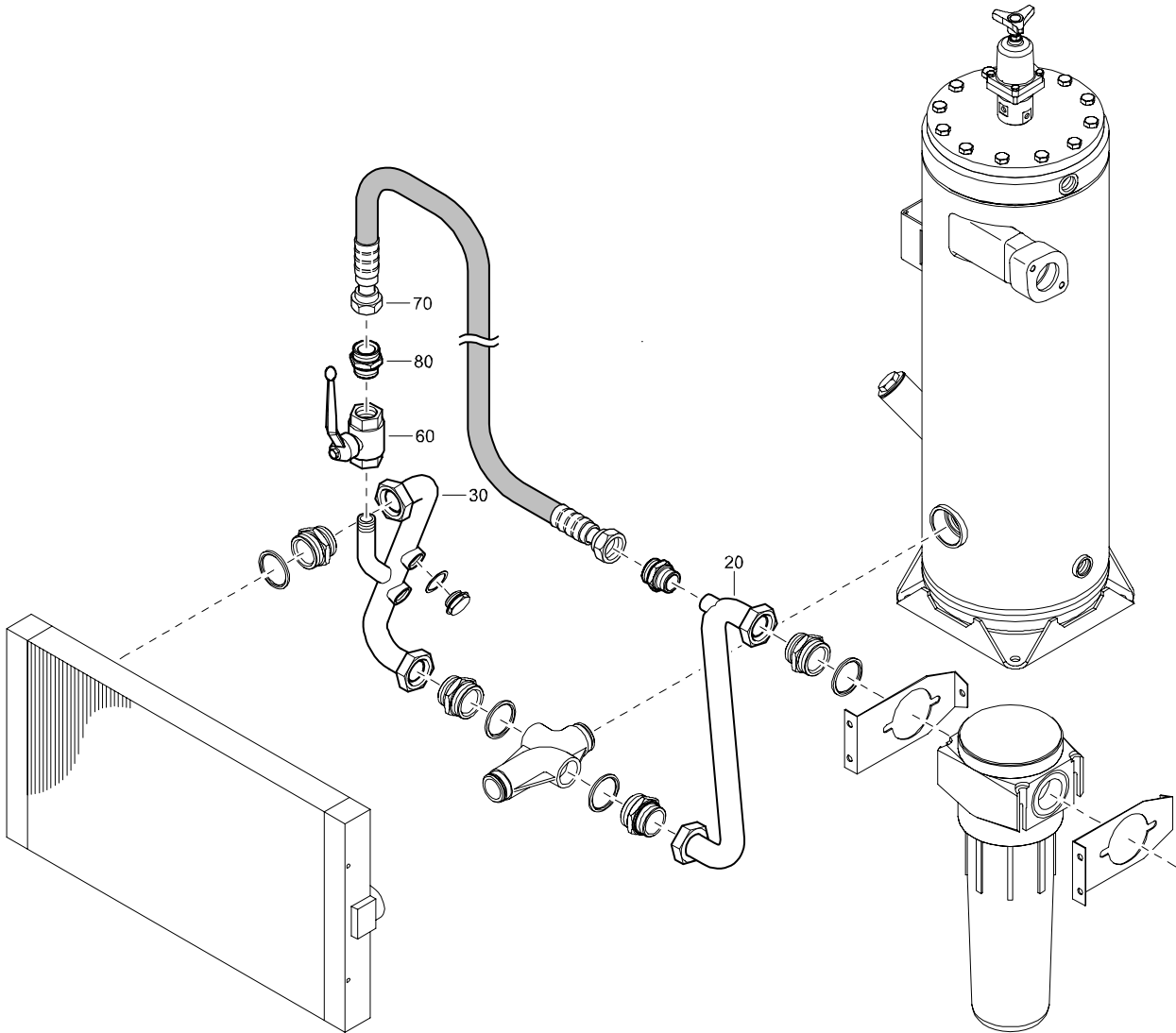

REF	PART NUMBER	DESIGNATION	QTY	REF	PART NUMBER	DESIGNATION	QTY
20	1604 3692 00	PIPE	1				
30	1604 3520 00	PIPE	1				
60	1619 6153 06	BALL VALVE	1				
70	1604 3521 00	HOSE ASSY	1				
80	2250 4983 00	NIPPLE	2				



---

# OPTIONS

## PIPE FOR COMPRESSOR WITHOUT REHEATER

---

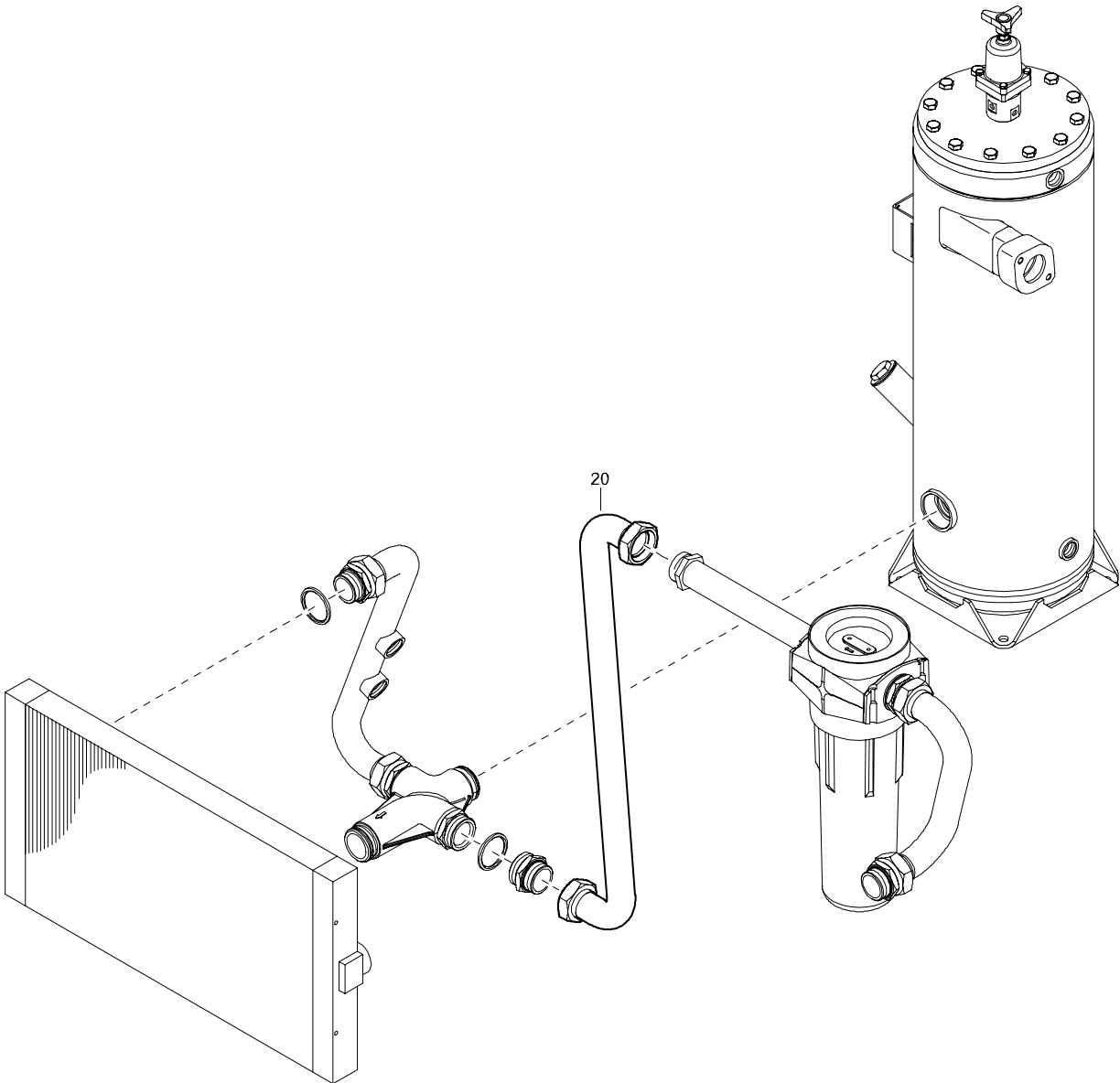

REF	PART NUMBER	DESIGNATION	QTY	REF	PART NUMBER	DESIGNATION	QTY
20	1604 0539 00	PIPE	1				

# OPTIONS

## REHEATER

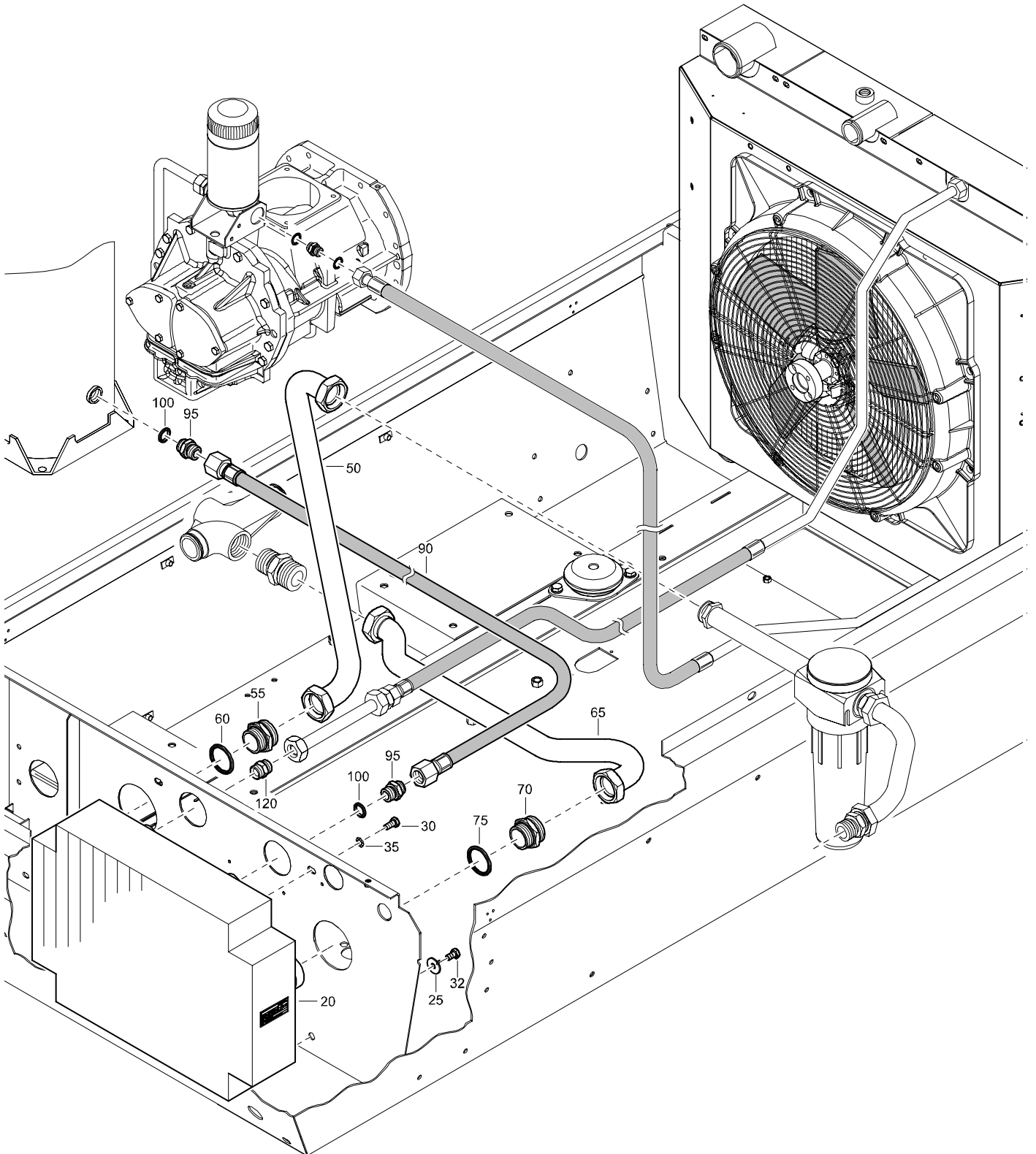

---

# OPTIONS

## REHEATER

---

REF	PART NUMBER	DESIGNATION	QTY	REF	PART NUMBER	DESIGNATION	QTY
20	1604 0541 00	REHEATER	1				
25	0300 8019 00	PLAIN WASHER	2				
30	0147 1321 03	HEX. HEAD SCREW	2				
32	0147 1322 03	HEX. HEAD SCREW	2				
35	0333 3227 00	LOCK WASHER	4				
50	1604 0540 00	PIPE	1				
55	0571 0035 41	HEXAGON NIPPLE	1				
60	0661 1062 00	SEALING WASHER	1				
65	1604 0542 00	PIPE	1				
70	0571 0035 41	HEXAGON NIPPLE	1				
75	0661 1062 00	SEALING WASHER	1				
90	0575 0365 38	HOSE ASSEMBLY	1				
95	1619 5509 00	NIPPLE	2				
100	0661 1033 00	SEALING WASHER	2				
120	1619 7842 00	JOINT NIPPLE	1				

# OPTIONS

## BALL VALVE FOR COMPRESSOR WITH FULL AFTERCOOLER BY-PASS

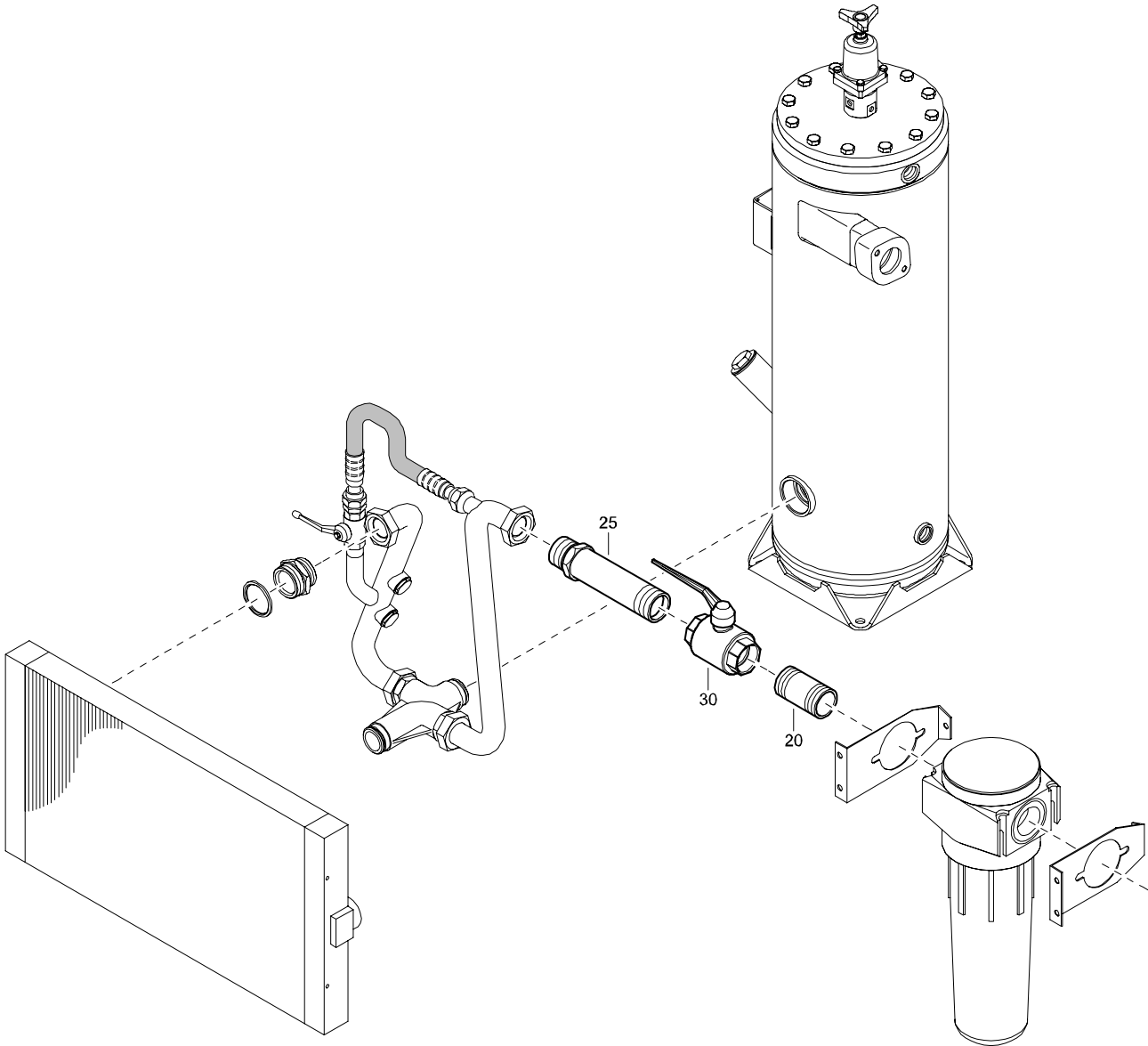

REF	PART NUMBER	DESIGNATION	QTY	REF	PART NUMBER	DESIGNATION	QTY
20	1604 4750 00	PIPE	1				
25	1604 0538 00	PIPE	1				
30	1619 6153 08	BALL VALVE	1				

# OPTIONS

## BALL VALVE FOR COMPRESSOR WITH PD FILTER AND FULL AFTERCOOLER BY PASS

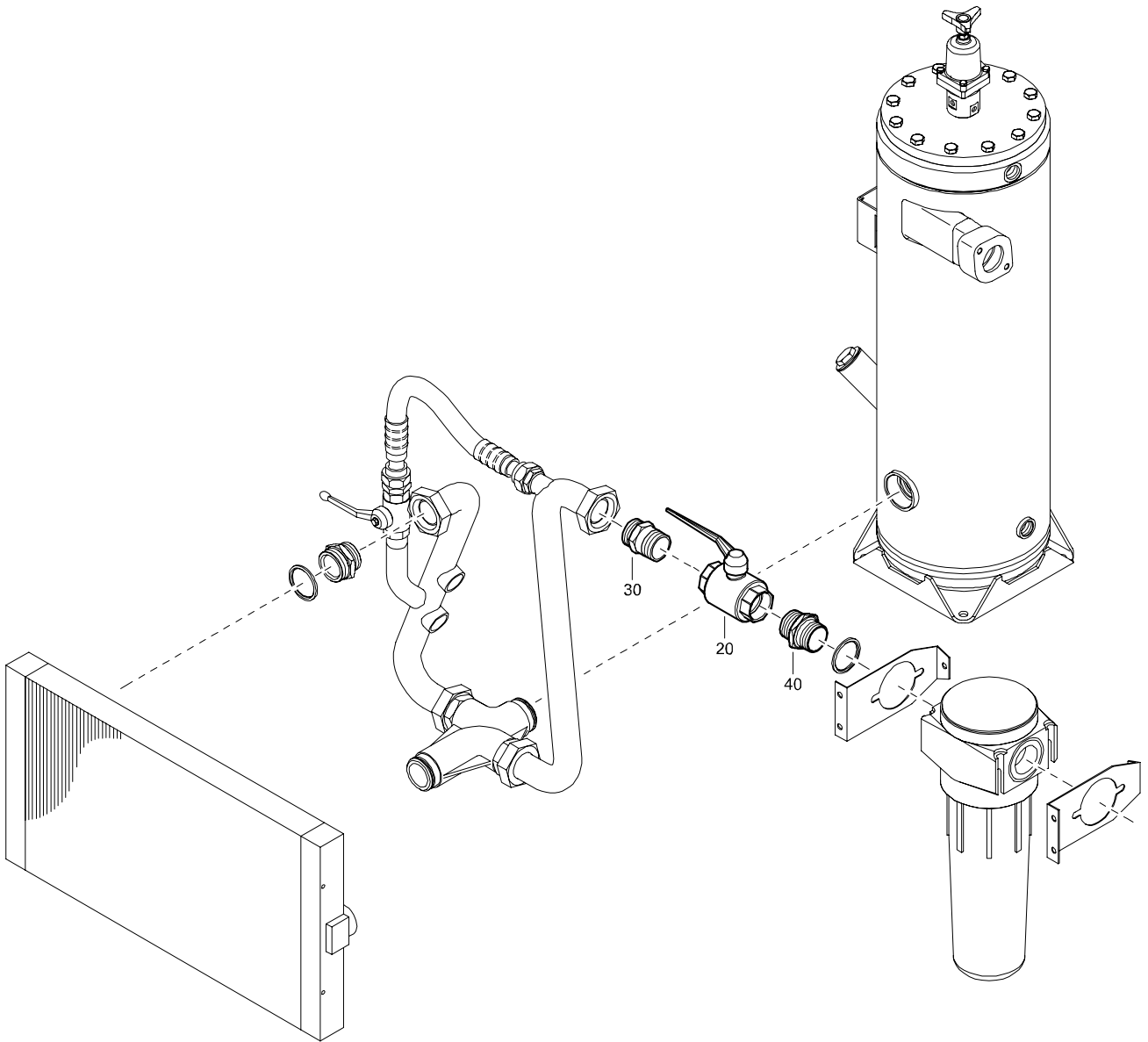

REF	PART NUMBER	DESIGNATION	QTY	REF	PART NUMBER	DESIGNATION	QTY
20	1619 6153 08	BALL VALVE	1				
30	1604 5162 00	PIPE	1				
40	0603 4108 03	HEXAGON NIPPLE	1				



**OPTIONS**  
**ENGINE AND OIL SEPARATOR**  
**FOR COMPRESSOR WITH COLD WEATHER EQUIPMENTS**  
**FOR EC**

REF	PART NUMBER	DESIGNATION	QTY	REF	PART NUMBER	DESIGNATION	QTY
50	1626 0707 00	ENGINE	1				
90	1604 0597 04	SUPPORT BATT.	1				
95	0147 1323 03	HEX. HEAD SCREW	2				
100	0301 2335 00	PLAIN WASHER	2				
110	0975 8300 16	BATTERY	1				
115	1604 0589 00	CLAMP	1				
120	1614 2246 03	STUD	2				
125	0333 3227 00	LOCK WASHER	2				
130	0266 2110 00	HEXAGON NUT	2				
170	1079 9920 00	INFORMATION LABEL	1				
175	1079 9920 45	INFORMATION LABEL	1				
176	1079 9924 44	INFORMATION LABEL	1				
200	1604 0301 04	BRACKET	1				
205	1619 7595 00	THERMOSTAT	1				
210	1613 6883 03	VALVE HOUSING	1				
215	1614 6118 00	COVER	1				
220	0663 2101 95	O-RING	1				
225	0147 1246 03	HEX. HEAD SCREW	2				
230	0147 1363 03	HEX. HEAD SCREW	2				
235	0301 2321 00	PLAIN WASHER	2				
240	0301 2344 00	PLAIN WASHER	2				
245	0266 2111 00	HEXAGON NUT	2				
260	0333 3132 00	LOCK WASHER	2				
270	0661 1038 00	SEALING WASHER	1				
300	1619 5509 00	NIPPLE	1				
305	0574 8235 37	HOSE ASSEMBLY	1				
310	0574 9841 22	HOSE ASSEMBLY	1				
320	1604 0382 91	OIL SEPARATOR	1				
		(For details see page 71)					
350	0661 1049 00	SEALING WASHER	2				
355	1612 0685 83	VALVE	2				

# OPTIONS

## ENGINE AND FITTINGS

### FOR COMPRESSOR WITH COLD WEATHER EQUIPMENT

### FOR ASME

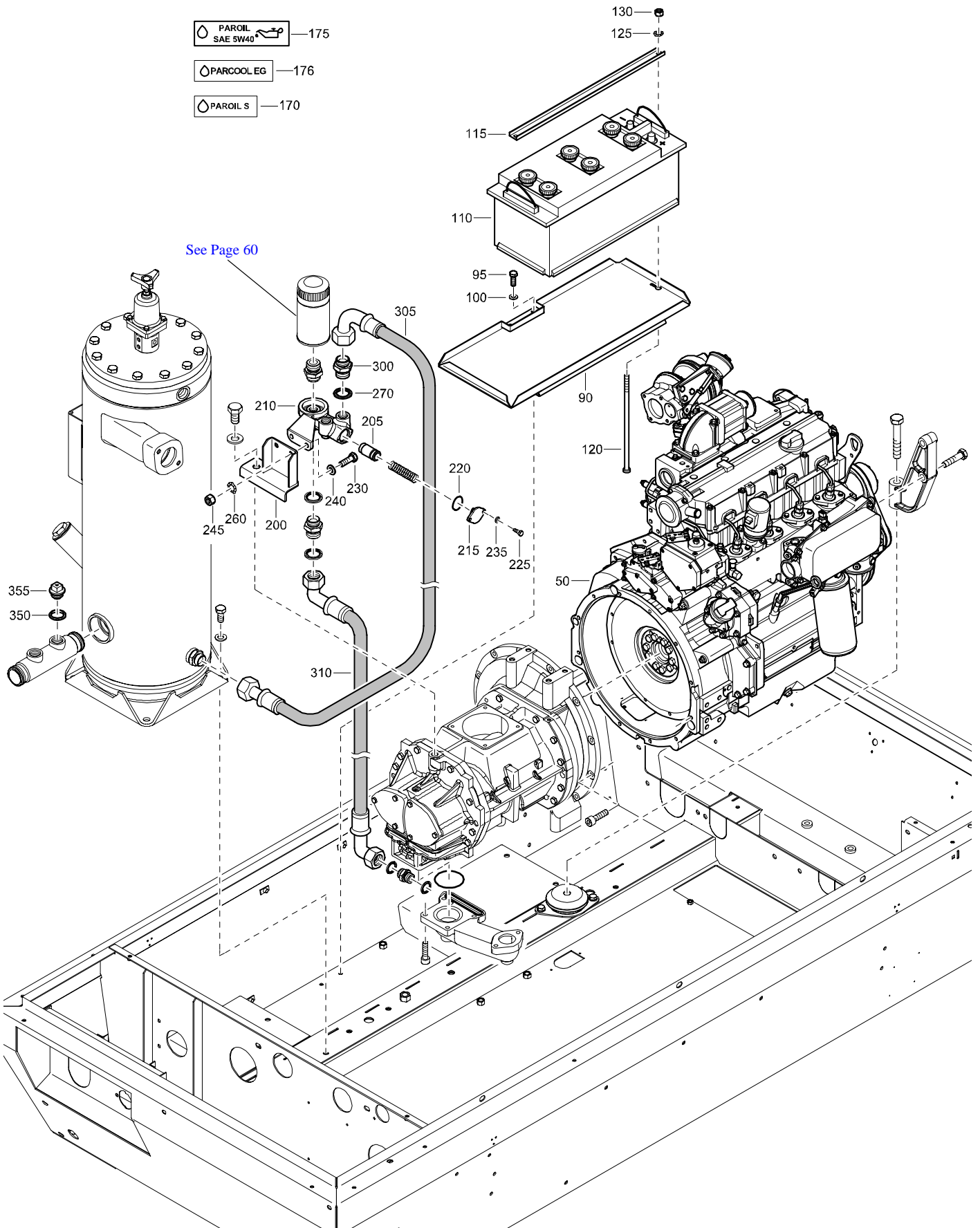



**OPTIONS**  
**ENGINE AND FITTINGS**  
**FOR COMPRESSOR WITH COLD WEATHER EQUIPMENT**  
**FOR ASME**

REF	PART NUMBER	DESIGNATION	QTY	REF	PART NUMBER	DESIGNATION	QTY
50	1626 0707 00	ENGINE	1				
90	1604 0597 04	SUPPORT BATT.	1				
95	0147 1323 03	HEX. HEAD SCREW	2				
100	0301 2335 00	PLAIN WASHER	2				
110	0975 8300 16	BATTERY	1				
115	1604 0589 00	CLAMP	1				
120	1614 2246 03	STUD	2				
125	0333 3227 00	LOCK WASHER	2				
130	0266 2110 00	HEXAGON NUT	2				
170	1079 9920 00	INFORMATION LABEL	1				
175	1079 9920 45	INFORMATION LABEL	1				
176	1079 9924 44	INFORMATION LABEL	1				
200	1604 0301 04	BRACKET	1				
205	1619 7595 00	THERMOSTAT	1				
210	1613 6883 03	VALVE HOUSING	1				
215	1614 6118 00	COVER	1				
220	0663 2101 95	O-RING	1				
225	0147 1246 03	HEX. HEAD SCREW	2				
230	0147 1363 03	HEX. HEAD SCREW	2				
235	0301 2321 00	PLAIN WASHER	2				
240	0301 2344 00	PLAIN WASHER	2				
245	0266 2111 00	HEXAGON NUT	2				
260	0333 3132 00	LOCK WASHER	2				
270	0661 1038 00	SEALING WASHER	1				
300	1619 5509 00	NIPPLE	1				
305	0574 8235 37	HOSE ASSEMBLY	1				
310	0574 9841 22	HOSE ASSEMBLY	1				
350	0661 1049 00	SEALING WASHER	2				
355	1612 0685 83	VALVE	2				

# OPTIONS

## WHEELCHOCKS

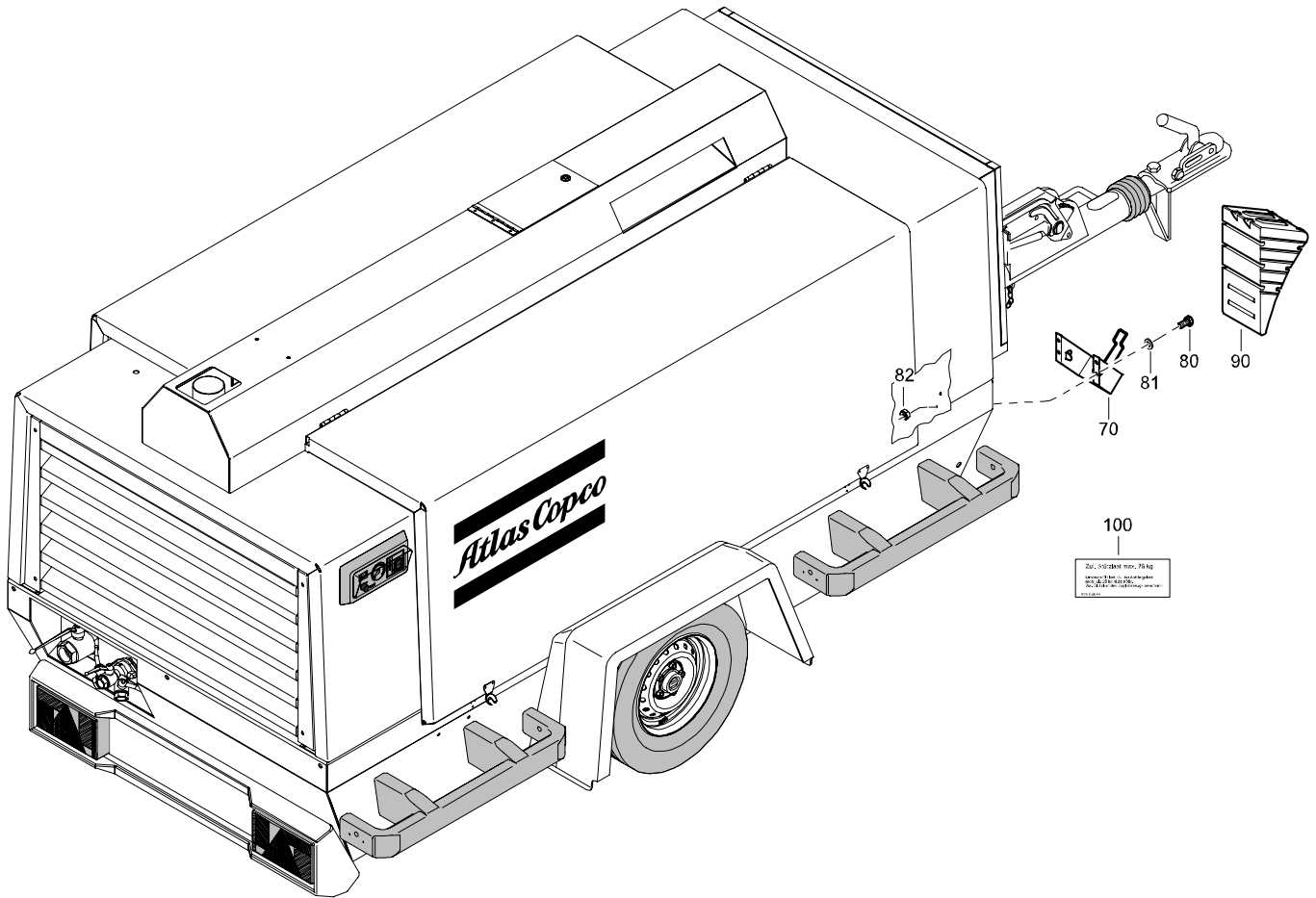

REF	PART NUMBER	DESIGNATION	QTY	REF	PART NUMBER	DESIGNATION	QTY
70	1202 9354 01	BRACKET	2				
80	0147 1244 03	HEX. HEAD SCREW	8				
81	0301 2321 00	PLAIN WASHER	8				
82	0291 1108 00	LOCKNUT	8				
90	1202 9353 01	WHEELCHOCKS	2				
100	1079 9902 64	LABEL	1				

# OPTIONS

## PANEL ASSEMBLY

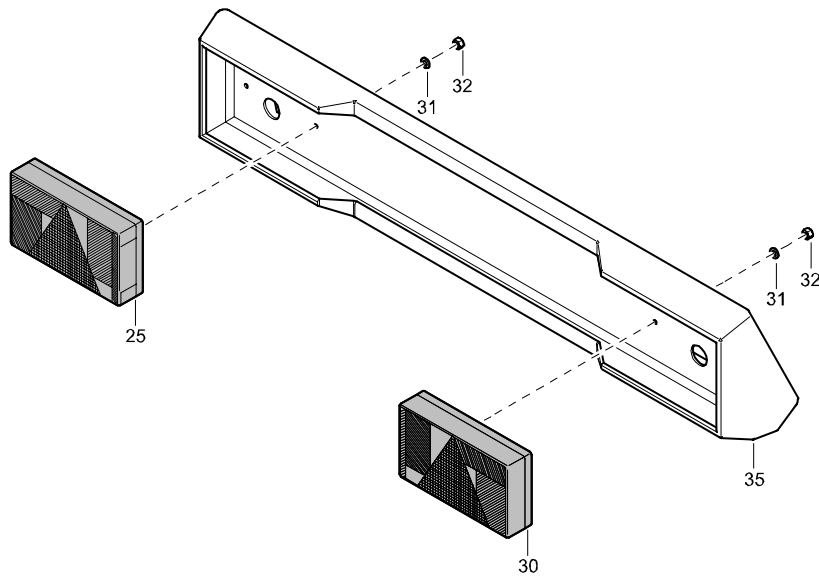

REF	PART NUMBER	DESIGNATION	QTY	REF	PART NUMBER	DESIGNATION	QTY
-	1604 0570 81	PANEL ASSY	(From page 98)				
•20	0226 3343 17	TAPPING SCREW	4				
•25	1604 0576 01	LIGHT LH	1				
•30	1604 0577 01	LIGHT RH	1				
•31	0301 2321 00	PLAIN WASHER	4				
•32	0266 2108 00	HEXAGON NUT	4				
•35	1604 0570 00	PANEL	1				

# OPTIONS

## AXLE WITH BRAKES

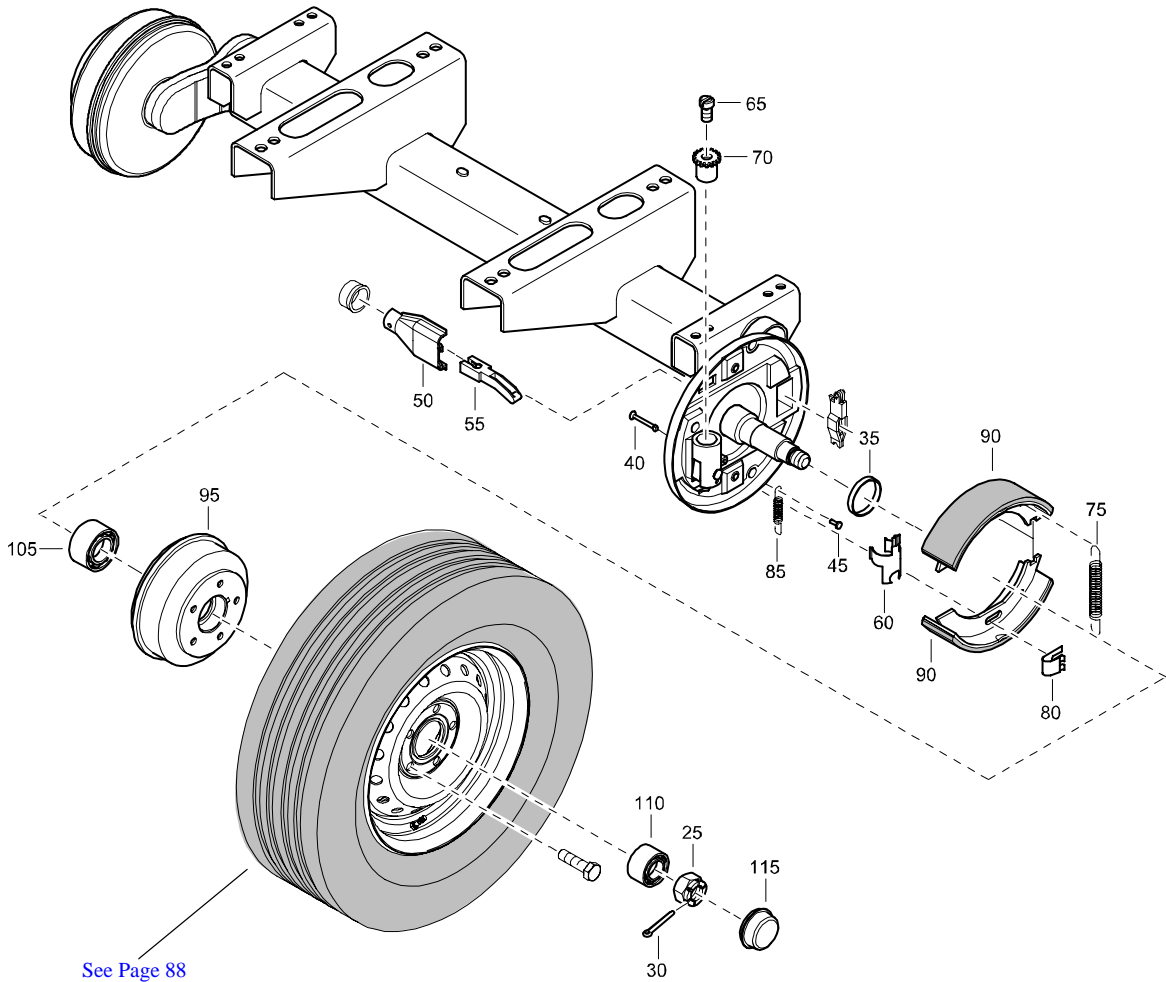

REF	PART NUMBER	DESIGNATION	QTY	REF	PART NUMBER	DESIGNATION	QTY
-	1604 0440 04	AXLE WITH BRAKES (From page 88, 90)		•90	-	BRAKE SHOE (Part of service kit, see page 25)	4
•20	-	AXLE (Not available separately)	1	•95	2914 2205 00	BRAKE DRUM	2
•25	-	CASTLED NUT (Part of service kit, see page 29)	2	•100	2914 0132 00	WHEEL BOLT	10
•30	-	SPLIT PIN (Part of service kit, see page 29)	2	•105	-	BEARING (Part of service kit, see page 29)	2
•35	-	SEAL RING (Part of service kit, see page 29)	2	•110	-	BEARING (Part of service kit, see page 29)	2
•40	-	PIN (Part of service kit, see page 25)	4	•115	-	CAP (Part of service kit, see page 29)	2
•45	2914 0182 00	BOLT	2				
•50	2914 2208 00	BUSHING	1				
•55	2914 0184 00	SHACKLE	2				
•60	2914 0185 00	CLAMP	2				
•65	2914 0187 00	SCREW	2				
•70	2914 0188 00	ADJUSTING NUT	2				
•75	-	SPRING (Part of service kit, see page 25)	2				
•80	-	SPRING (Part of service kit, see page 25)	4				
•85	-	SPRING (Part of service kit, see page 25)	2				

# OPTIONS

## AXLE FOR COMPRESSOR WITH FIXED TOWBAR & WITHOUT BRAKES

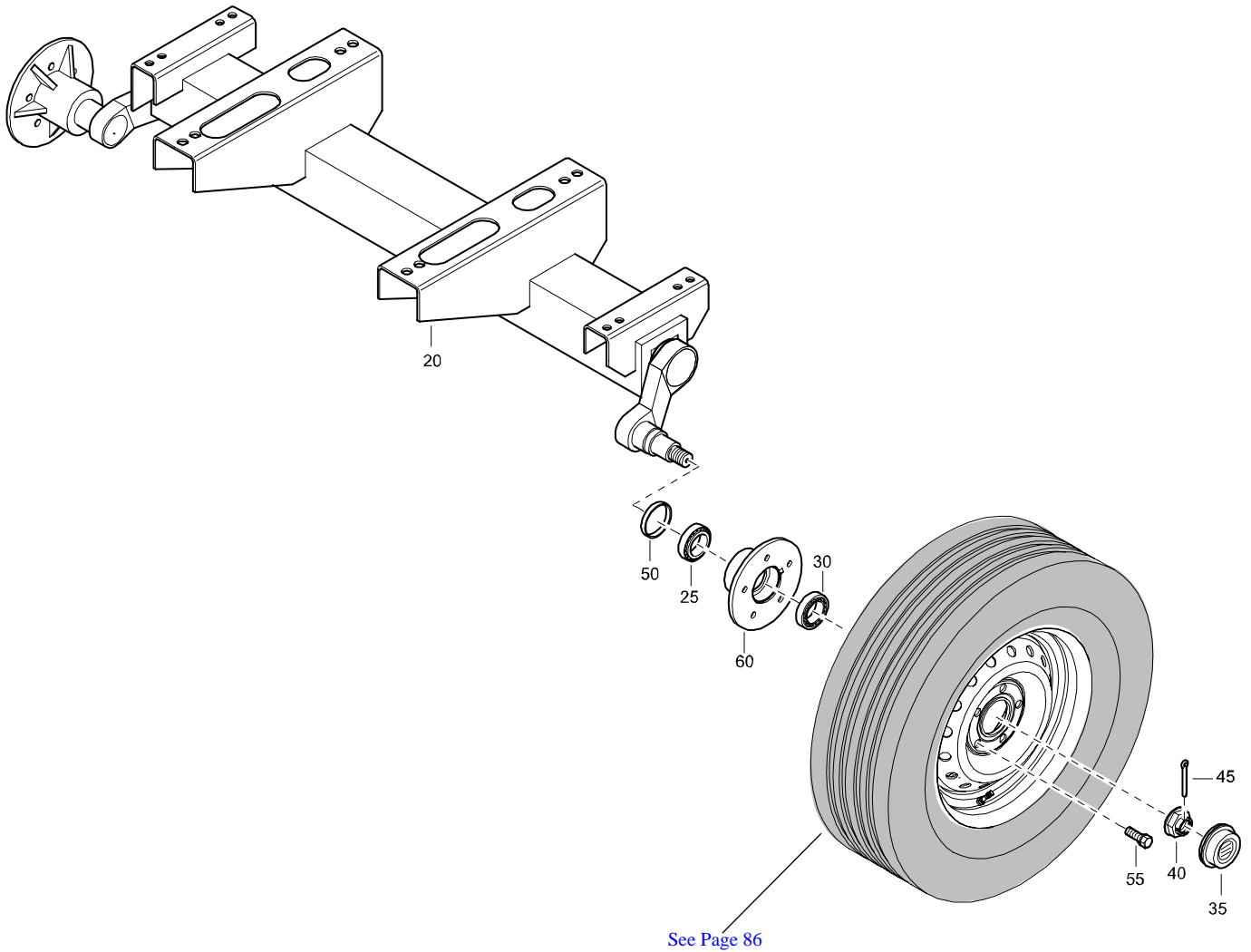

REF	PART NUMBER	DESIGNATION	QTY	REF	PART NUMBER	DESIGNATION	QTY
-	1604 0441 02	AXLE NO BRAKES <a href="#">(From page 86)</a>	1				
•20	-	AXLE (Not available separately)	1				
•25	-	BEARING <a href="#">(Part of service kit, see page 29)</a>	2				
•30	-	BEARING <a href="#">(Part of service kit, see page 29)</a>	2				
•35	-	CAP <a href="#">(Part of service kit, see page 29)</a>	2				
•40	-	CASTLED NUT <a href="#">(Part of service kit, see page 29)</a>	2				
•45	-	SPLIT PIN <a href="#">(Part of service kit, see page 29)</a>	2				
•50	-	SEAL RING <a href="#">(Part of service kit, see page 29)</a>	2				
•55	2914 0132 00	WHEEL BOLT	10				
•60	2914 2206 00	HUB	2				

# OPTION

## TOWBAR FOR COMPRESSOR WITH FIXED TOWBAR & BRAKES

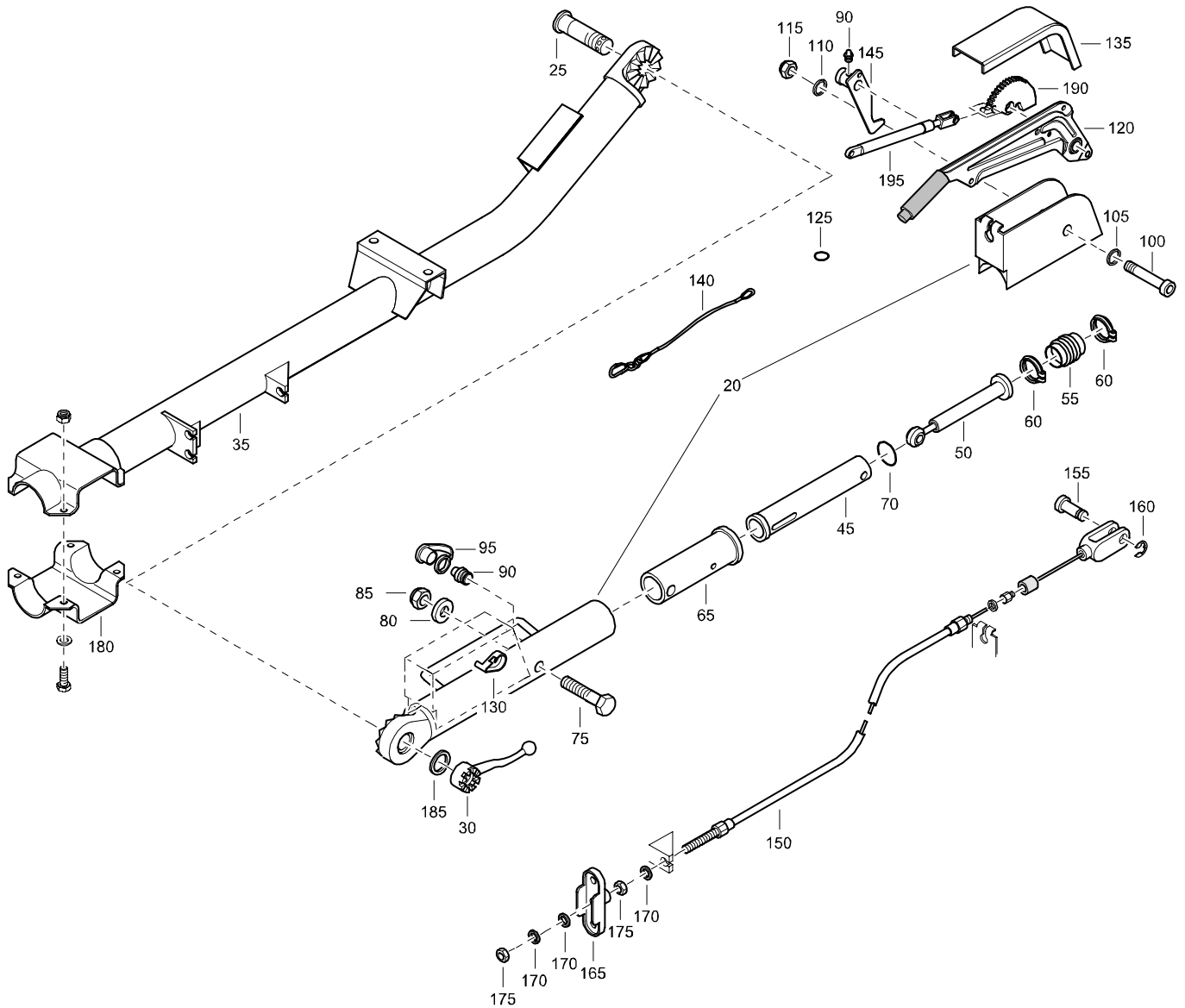

REF	PART NUMBER	DESIGNATION	QTY	REF	PART NUMBER	DESIGNATION	QTY
-	1604 0443 02	TOWBAR FIXED WITH BRAKES (From page 88)		•130	2914 2200 00	LEVER	1
•20	2914 2192 00	HOUSING	1	•135	2914 2138 00	COVER PLATE	1
•25	2900 0833 00	BOLT	1	•140	2900 0814 00	CABLE	1
•30	2900 0834 00	HANDLE	1	•145	2914 2201 00	LEVER	1
•35	2914 2193 00	TOWBAR	1	•150	2914 2008 00	BRAKE CABLE	1
•40	2900 0836 00	CLIP	1	•155	2914 2025 00	BOLT	1
•45	2914 2194 00	BUSHING	1	•160	2914 2026 00	CLASP	1
•50	2914 2195 00	SCHOCK ABSORBER	1	•165	2914 2202 00	EQUALIZER	1
•55	2914 2196 00	BELLOWS	1	•170	2914 2045 00	RING	3
•60	1088 1301 00	CABLE STRIP	2	•175	2900 0729 00	NUT	2
•65	2914 2197 00	BUSH	1	•180	2900 0823 00	CLAMP	1
•70	2900 0450 00	O-RING	1	•185	2900 0841 00	CLIP	1
•75	2914 2198 00	BOLT	1	•190	2914 2188 00	BRAKE SEGMENT	1
•80	2914 2010 00	WASHER	1	•195	2914 2097 00	DAMPER	1
•85	2914 2011 00	NUT	1				
•90	1619 2642 00	GREASE NIPPLE	2				
•95	2900 0850 00	CAP	1				
•100	2914 2094 00	BOLT	1				
•105	2900 1157 00	WASHER	1				
•110	2914 2199 00	WASHER	1				
•115	2914 2095 00	NUT	1				
•120	2914 2096 00	LEVER	1				
•125	2900 0424 00	RING	1				

# OPTIONS

## TOWBAR FOR COMPRESSOR WITH FIXED TOWBAR & WITHOUT BRAKES

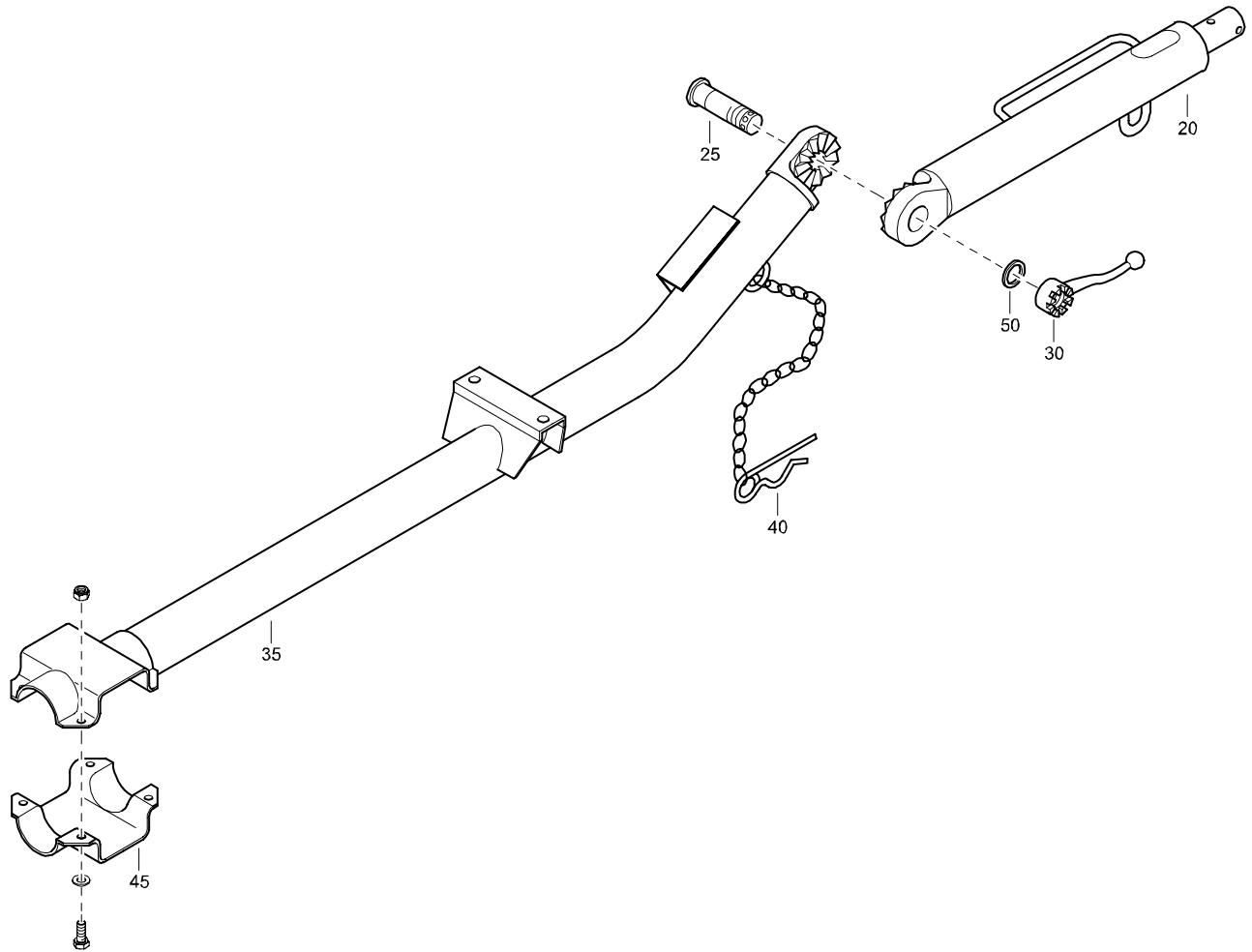

REF	PART NUMBER	DESIGNATION	QTY	REF	PART NUMBER	DESIGNATION	QTY
-	1604 0444 02	TOWBAR FIXED - NO BRAKES(From page 86)					
•20	2914 2190 00	HOUSING	1				
•25	2900 0833 00	BOLT	1				
•30	2900 0834 00	HANDLE	1				
•35	2914 2191 00	ROD	1				
•40	2900 0836 00	CLIP	1				
•45	2900 0823 00	CLAMP	1				
•50	2900 0841 00	CLIP	1				

# OPTIONS

## TOWBAR FOR COMPRESSOR WITH ADJUSTABLE TOWBAR & BRAKES

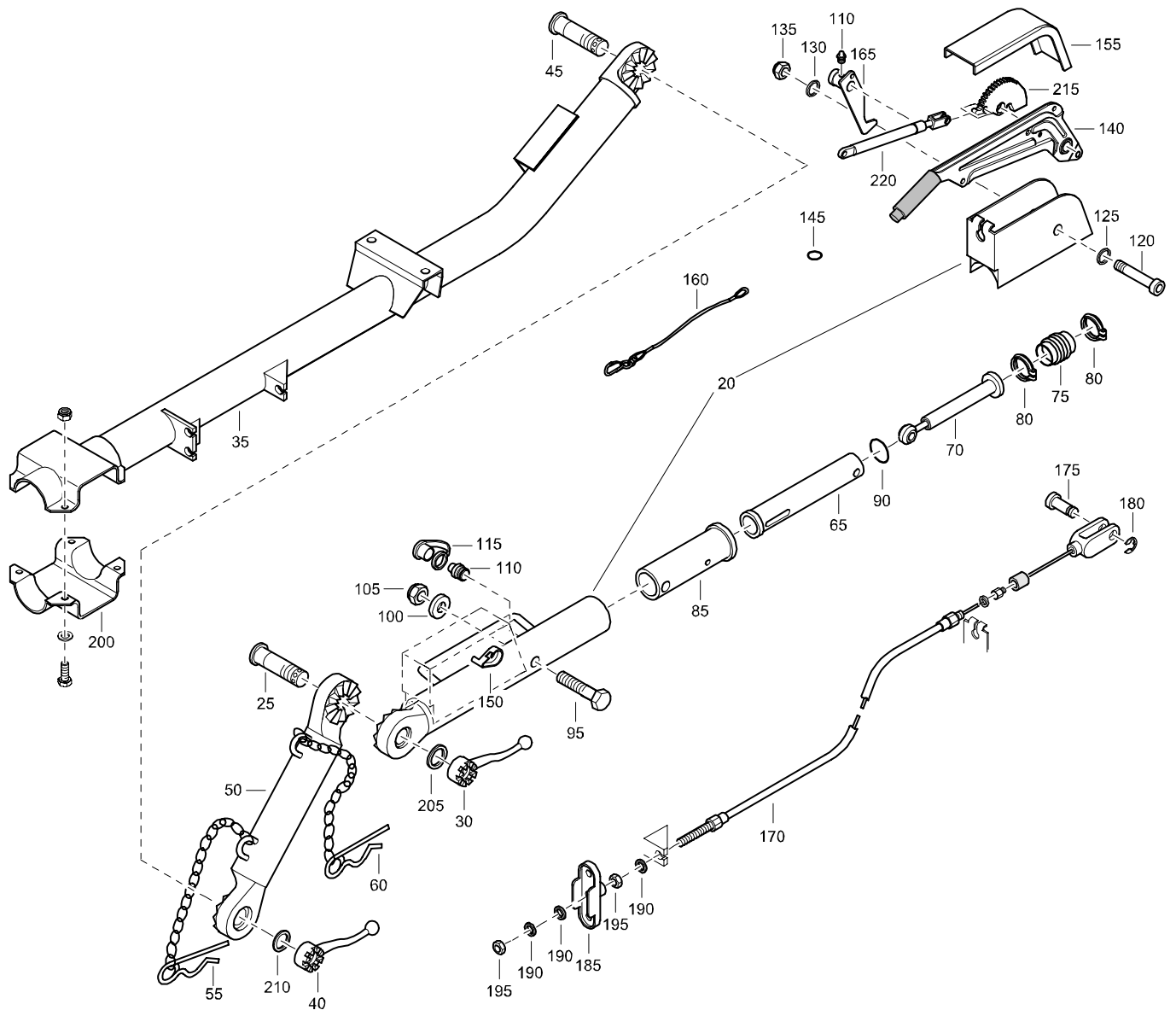

REF	PART NUMBER	DESIGNATION	QTY	REF	PART NUMBER	DESIGNATION	QTY
-	1604 0445 00	TOWBAR ADJ. WITH BRAKES (From page 90)		•135	2914 2095 00	NUT	1
•20	2914 2192 00	HOUSING	1	•140	2914 2096 00	LEVER	1
•25	2900 0833 00	BOLT	1	•145	2900 0424 00	RING	1
•30	2900 0834 00	HANDLE	1	•150	2914 2200 00	LEVER	1
•35	2914 2203 00	TOWBAR	1	•155	2914 2138 00	COVER PLATE	1
•40	2900 0840 00	HANDLE	1	•160	2900 0814 00	CABLE	1
•45	2900 0839 00	BOLT	1	•165	2914 2201 00	LEVER	1
•50	2900 0721 00	ROD	1	•170	2914 2204 00	BRAKE CABLE	1
•55	2900 0836 00	CLIP	1	•175	2914 2025 00	BOLT	1
•60	2900 0837 00	CLIP	1	•180	2914 2026 00	CLASP	1
•65	2914 2194 00	BUSHING	1	•185	2914 2202 00	EQUALIZER	1
•70	2914 2195 00	SCHOCK ABSORBER	1	•190	2914 2045 00	RING	3
•75	2914 2196 00	BELLOWS	1	•195	2900 0729 00	NUT	2
•80	1088 1301 03	CABLE STRIP	2	•200	2900 0823 00	CLAMP	1
•85	2914 2197 00	BUSH	1	•205	2900 0841 00	CLIP	1
•90	2900 0450 00	O-RING	1	•210	2900 0835 00	CLIP	1
•95	2914 2198 00	BOLT	1	•215	2914 2188 00	BRAKE SEGMENT	1
•100	2914 2010 00	WASHER	1	•220	2914 2097 00	DAMPER	1
•105	2914 2011 00	NUT	1				
•110	1619 2642 00	GREASE NIPPLE	2				
•115	2900 0850 00	CAP	1				
•120	2914 2094 00	BOLT	1				
•125	2900 1157 00	WASHER	1				
•130	2914 2199 00	WASHER	1				



# Parts from Service Pak

(ACTUAL SIZE)

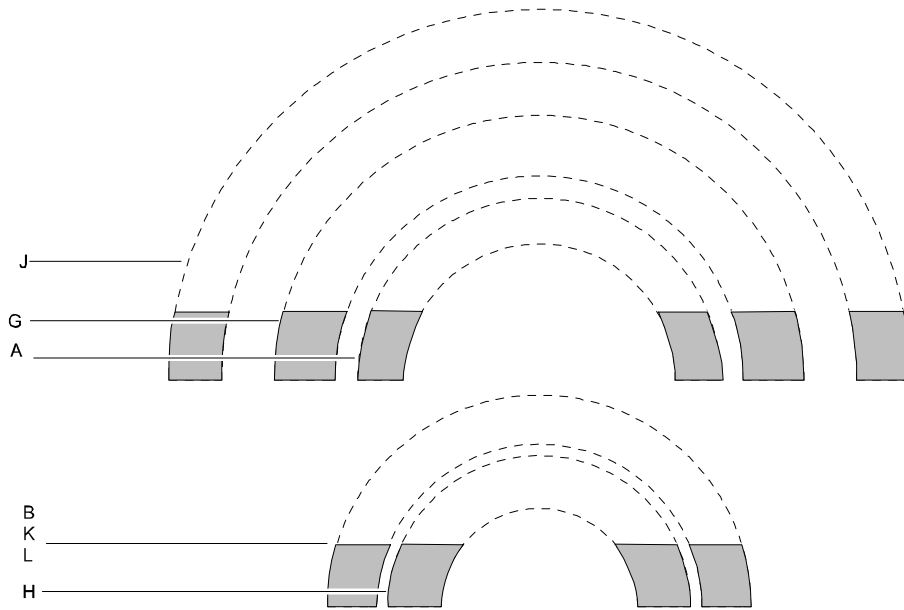

REF	PART NUMBER	DESIGNATION	QTY	REF	PART NUMBER	DESIGNATION	QTY
-	-	PARTS FROM SERVICE PAK					
		(From page 17)					
•A	-	FLAT GASKET	1				
•B	-	SEALING WASHER	1				
•G	-	SEALING WASHER	1				
•H	-	FLAT GASKET	1				
•J	-	FLAT GASKET	1				
•K	-	SEALING WASHER	1				
•L	-	SEALING WASHER	1				







[www.atlascopco.com](http://www.atlascopco.com)

Printed in Belgium 01/2007 - 2955 1070 00